



Joint
Advanced
Warfighting
Program

INSTITUTE FOR DEFENSE ANALYSES

**Al Sahawa—The Awakening
Volume IV: Al Anbar Province, Area of
Operations Topeka, Ramadi**

Dr. William (Bill) Knarr, Task Leader
Col Dale Alford, USMC
Mary Hawkins
LtCol David Graves, USMC
Jennifer Goodman
Matthew Dobson
Carolyn Leonard
John Frost
Col Tracy King, USMC
MajGen Thomas Jones, USMC, (Ret)
Matt Coursey

August 2016
Approved for public
release; distribution is
unlimited.
IDA Paper P-5052
Log: H 13-001038



The Institute for Defense Analyses is a non-profit corporation that operates three federally funded research and development centers to provide objective analyses of national security issues, particularly those requiring scientific and technical expertise, and conduct related research on other national challenges.

About This Publication

This work was conducted by the Institute for Defense Analyses (IDA) under contract DASW01-04-C-0003, Task AI-8-2827, for the Joint Advanced Warfighting Program (JAWP) Board of Directors and Task BE-8-3035, the Under Secretary of Defense for Personnel and Readiness. The JAWP Board consists of the Deputy Commander, US Joint Forces Command; the Deputy, Joint Operations Support, Assistant Secretary of Defense for Acquisition; the Deputy Assistant Secretary of Defense for Strategy; and the Joint Staff Director for Joint Force Development (J 7). The views, opinions, and findings should not be construed as representing the official position of either the Department of Defense or the sponsoring organization.

Acknowledgements

The authors would like to thank the Marine Corps History Division for opening their files to the team, Sheikh Ahmed Bezia Albu-Risha for opening his home and hosting many of the Iraqi interviews, and the US Forces Iraq for making the battle site surveys and in-country interviews possible. We would like to particularly thank all of the interviewees that took the time out of their busy schedule to talk to the JAWD team, sometimes at their own risk. Special thanks to Dr. Kevin Woods and Colonel Scott Feil, USA, (Ret), for their expertise and coaching throughout the review and publication process —they were incredibly helpful in getting these stories published.

Copyright Notice

© 2013, 2016 Institute for Defense Analyses
4850 Mark Center Drive, Alexandria, Virginia 22311-1882 • (703) 845-2000

This material may be reproduced by or for the U.S. Government pursuant to the copyright license under the clause at DFARS 252.227-7013 (a)(16) [Jun 2013]

INSTITUTE FOR DEFENSE ANALYSES
Joint Advanced Warfighting Program

IDA Paper P-5052

**Al Sahawa—The Awakening
Volume IV: Al Anbar Province, Area of
Operations Topeka, Ramadi**

Dr. William (Bill) Knarr, Task Leader
Col Dale Alford, USMC
Mary Hawkins
LtCol David Graves, USMC
Jennifer Goodman
Matthew Dobson
Carolyn Leonard
John Frost
Col Tracy King, USMC
MajGen Thomas Jones, USMC, (Ret)
Matt Coursey

Executive Summary

The purpose of the Anbar Awakening project, and the five volumes that document its findings, is to tell the story of Al Anbar's *Sahawa*.¹ In doing so, it will show that there were a number of developments throughout Al Anbar between 2003 and 2008 that significantly contributed to the overall Awakening story. This document, Volume IV, addresses events in the Ramadi district of the Coalition's Area of Operations (AO) Topeka.

In 2004, as media, world and Coalition attention was captured by insurgent domination of Fallujah, a lesser publicized but just as lethal insurgency was developing in the neighboring city of Ramadi. That insurgency grew and became more dominant after Operation AL FAJR in November and December 2004, as insurgents fled west from the fighting in Fallujah to Ramadi, the Hadithah-Hit Corridor, Al Qaim along the Syrian border and north to Mosul.

Throughout 2005 the Coalition and Iraqis increased forces in the Al Qaim area and the Corridor. As they started to take control of those areas, insurgents were pushed or perhaps willingly gravitated to Ramadi. After all, Ramadi was AQI's proclaimed Caliphate. Blocked by operations in Fallujah to the east and driven by an increased Coalition and Iraqi security presence in the west, the insurgency was running out of room to maneuver. In 2006, Ramadi had become AQI's last major safe haven in Al Anbar and the most dangerous city in the world.

This volume discusses conditions during 2004 and 2005 as background but focuses on the period 2006-2007 in Ramadi and includes Sheikh Sattar Albu-Risha's 14 September 2006 *Al Sahawa* pronouncement, the event that most people associate with the Awakening movement. However, the evolution of the Awakening movement and success in ridding Ramadi of AQI's domination was much deeper and complex than the storybook scenario most people visualize when they think of the Awakening. Partnering with the tribes was key, but there was much more to it than that. There was a certain sequence of events, planned and unplanned, that took place that allowed the Awakening to move forward. As Colonel Sean MacFarland, Commander of the Ready First Combat Team in Ramadi described it, "every step of the way it was 'Are we going to get the next break?' And we did, we did!"

Objective

The objective of the Anbar Awakening project is to create an unclassified, credible resource for trainers and educators. It is presented in multimedia to accommodate different

¹ *Sahawa* means Awakening in Arabic.

teaching and learning styles.² The project presents the Awakening movement's phases from the development of the insurgency in 2003 to the Coalition's transfer of responsibility for Al Anbar to the Iraqis in 2008. In addition, it offers analysis and lessons, many of which are transferrable to current and future conflicts.

Reconstruction

Reconstructing the events in Al Anbar into a multimedia product begins where most case studies, historical analyses, and comparable projects end. The case study has to be completed first; next (or simultaneously, if possible), multimedia materials need to be collected; and then those materials have to be woven together to bring the case study to life. Much of the information came through interviews. Chapter 2 of this document summarizes the transcripts of those interviews contained in the appendices. That summary and those of the other volumes provide the script—the storyboard—with quotes that identify potential “characters” and video or audio clips for the multimedia product.

The Awakening project comprises five volumes of supporting documents and an interactive DVD with a Teacher's Guide. The purpose of the Teacher's Guide is to suggest how an instructor might use the DVD and the various volumes to support and inform research, training and education. It provides storyline experiences that may be relevant to on-going conflicts and examples that allow students to see the strategic implications of tactical actions and visa-versa. Volume I is the final report and Volumes II–V, arranged by AO, from strategic to tactical levels, contain background on each AO, transcripts from interviewees who worked in those AOs, and summaries of those transcripts (see Figure).

² Professional Military Education institutes have asked for unclassified, public releasable material to be used in their seminars.

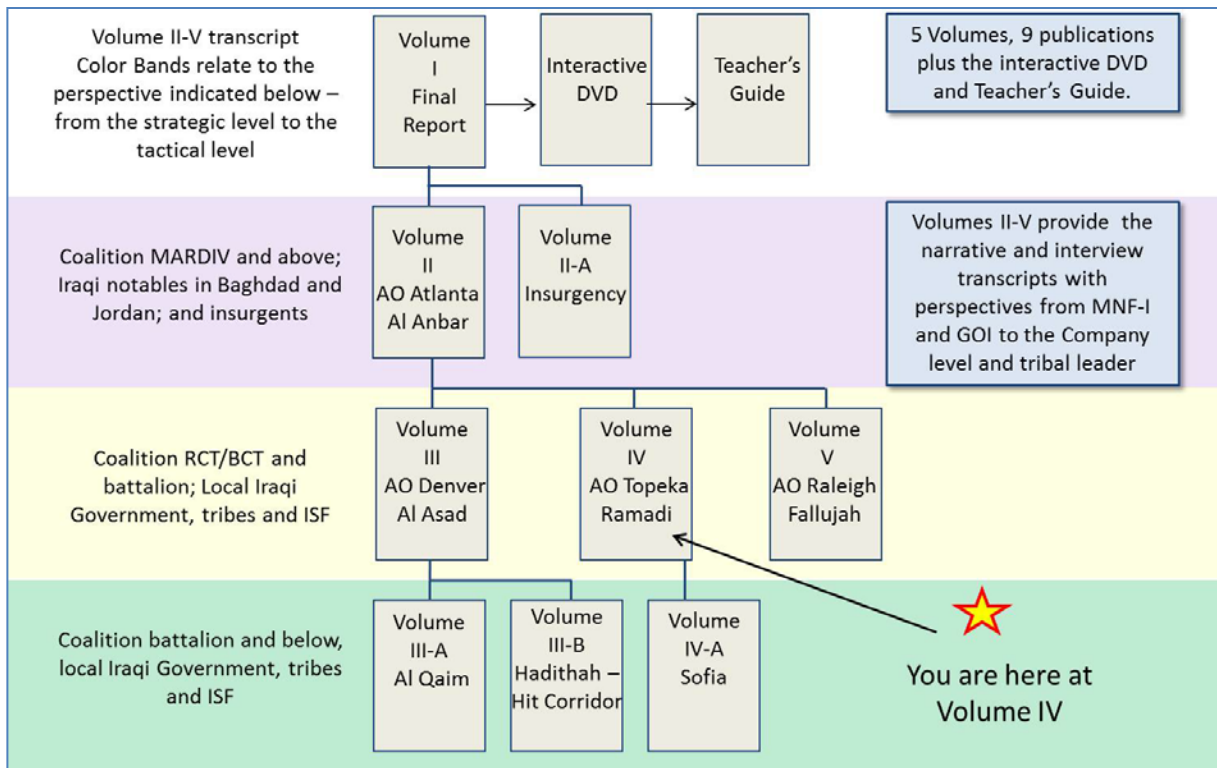

Areas of Operation in Al Anbar provide the structure for the Awakening volumes

This Volume

This volume addresses events in Ramadi during 2006 and 2007. It provides both Iraqi and Coalition perspectives, in Appendices A and B respectively, on events in the area that impacted the evolution of the area from an insurgent stronghold to an area that supported the Coalition and Government of Iraq (GOI).

Themes and Leads

Each volume in this study provides themes corresponding to significant events in each AO. Below are the themes and leads gleaned from the events that occurred in Ramadi; events that were significant and similar or dissimilar to other areas of Al Anbar are also noted.

1. Experience of the Coalition force was extraordinary!

According to COL MacFarland, 40–50% of the brigade were veterans from the brigade's previous deployment; with new folks who had previously deployed with other units, the brigade consisted of more than 50% veterans.

Lieutenant Colonel Ferry commanded 1st Battalion, 9th Infantry Regiment (1-9 Infantry). Of 1-9 Infantry, about 35% of the battalion had served during its deployment as 1-503 Air Assault and approximately 70% had served previous combat tours. All of the company

commanders had previous combat tours and all had come from the Ranger Regiment or the Ranger Training Brigade.³

Lieutenant Colonel Bill Jurney commanded 1/6 Marines in Fallujah from March to October of 2005. He deployed that battalion of veterans one year later to Ramadi.

2. Benefits of a dress rehearsal

The 1st Brigade Combat Team (BCT) of the 1st Armored Division, also known as the Ready First Combat Team (RFCT) received word in May of 2006 that they were going to deploy from Tal Afar to Ramadi. Although the enemy activity level in Tal Afar was not as high as it would be in Ramadi, according to Colonel Sean MacFarland, RFCT Commander, “it was a pretty good dress rehearsal for what we ended up doing in Ramadi.”

3. Not all Awakenings are the same

The evolution of events in the Ramadi area illustrate that not all awakenings are the same. Typically, people associate the awakening with the tribes, but in some cases such as the city, there were no dominant tribes or tribal leaders willing to take charge. As an example, in Ramadi, the local leader that took charge was Col Ahmed Hamid Sharqi, Chief, North Ramadi Police Precinct.

This also occurred in Hadithah. As Abd al-hakim Muhammad Rashid, the mayor of Hadithah indicated, “there was no popular militia to fight the *sahawa*” in Hadithah as there was in Al Qaim or Ramadi.⁴ Baghdadi’s awakening was also different in that a courageous Iraqi, Colonel Shaban Barzan Abdul Himrin Al-Ubaydi went home to Baghdadi and decided to organize a police force to fight AQI.

4. Combined, permanent, persistent presence

Several things were critical to this theme: building partner capacity, population control measures and engineer support. Both Coalition and Iraqi forces were critical to setting the conditions for developing the police force. LTC Deane made an interesting comment that had the American forces been more robust, they may not have engaged with the Iraqis as intensely as they did.

Unfortunately, population control measures, such as berming were not practical because of the size, density and sprawl of the city.⁵ However, Coalition used natural and man-made

³ Lieutenant Colonel Chuck Ferry, USA, Retired, interview with Dr. William Knarr, Colorado Springs, Colorado, 8 November 2010.

⁴ Abd al-hakim Muhammad Rashid, Hadithah Mayor, interview with Dr. William Knarr, Colonel Dale Alford, USMC, and Lieutenant Colonel David Graves, USMC, at his office in Hadithah, Iraq, 14 April 2010.

⁵ This was done in Fallujah during and at the conclusion of Operation AL FAJR and also in the Hadithah Triad.

features, such as the Euphrates River, lakes, canals, and railroads, to their advantage as they planned and executed operational control over the city.⁶ They then moved, generally, from west to east to push insurgents from AO Topeka.

Engineer support was integral to the strategy. In addition to capitalizing on terrain features noted above, their mobility/counter mobility efforts canalized the enemy with barriers and freed up routes for friendly movement. Additionally, they built the combat outposts which allowed the Coalition and Iraqi's to "hold" in an area and sustain large scale attempts to remove them.

Continuous Storyline Connected by Relationships and Events

The Awakening was much more than Sheikh Sattar's announcement on 14 September coining the term *Sahawa*. Governor Mamoun Sami Rashid, Al Anbar Governor 2005–06 provided a sequence of actions throughout Al Anbar that culminated in the awakening in Ramadi:

When we started fighting Al Qaeda in Fallujah [2004], the fight started to trickle down to Al Qaim [2005], then Hadithah [2006], then Anah, Rawah, and all these cities. The tribes with the help of the coalition forces, they took the fight to Al Qaeda. The last round of fighting was in Ramadi [2006/2007].⁷

Additionally, these areas were connected through the "Sheikh network," that unofficial grapevine of social connectivity that Americans were not part of. Rather than the starting point, Sheikh Sattar's *Sahawa* was the product of accumulating events.

Engagement and Relationships

Many people speak of engaging the population and the importance of relationships. Charlton saw that "your relationship with the population is your force protection" and described it in terms of different "doors" into the society and what those doors provided. According to COL John Charlton, Commander, 1st Brigade Combat Team, 3rd Infantry Division, the normal doors are the ones to security and government forces. Another door is to the elected or appointed officials. "We got those." But there are three other doors that are critical, in particular in a country like Iraq. They are "tribal leadership, religious leadership and reconciliation."⁸ Chapter two provides more detail on those doors and ends with the last slide in Captain Travis Patriquin's stick figure presentation on engaging the Iraqis and describing, "How to Win in Al Anbar."

⁶ Typically analyzed as they developed their Modified Combined Obstacle Overlay (MCOO). Major Damon Mitchell, former commander, Bravo Company, 16th Engineer Battalion, interview with Dr. William Knarr in Fairfax Station, Virginia, on 19 December 2010.

⁷ Governor Mamoun Sami Rashid, Al Anbar Governor 2005 to 2006, interview with Dr. William Knarr, Colonel Dale Alford, USMC, and Lieutenant Colonel David Graves, USMC, in Ramadi, on 7 April 2010.

⁸ Colonel John Charlton, interview with Dr. William Knarr, 20 October 2010.

Contents

1. The Awakening	1-1
A. Objective	1-1
B. Collection	1-2
C. Publication Series and Structure	1-2
D. The Volumes	1-3
E. This Volume.....	1-4
2. Ramadi	2-1
A. The Ready First Combat Team Deploys to Ramadi	2-1
B. Task Force 1-35 Armor.....	2-6
C. Confusing Signals—the Fog of War?	2-10
D. <i>Al Sahawa</i> , An Awakening	2-11
E. Task Force 1/6 Marines.....	2-15
F. TF 1/6 Marines: The Third Line of Operation.....	2-19
G. The Engineer’s Contribution.....	2-20
H. Task Force 1st Battalion, 9th Infantry Regiment	2-22
I. Other Iraqi Leaders Who made a Difference	2-24
J. Continued Progress in Ramadi.....	2-24
K. The 1st Brigade Combat Team, 3rd Infantry Division	2-26
L. Themes and Lessons	2-29
Appendix A: Coalition Perspectives	A-1
Appendix B: Iraqi Perspectives.....	B-1
Appendix C: Who’s Who.....	C-1
Appendix D: Maps	D-1
Appendix E: Illustrations	E-1
Appendix F: References	F-1
Appendix G: Abbreviations	G-1

1. The Awakening⁹

At a 14 September 2006, meeting in Ramadi, three days after a classified report was leaked to the *Washington Post* announcing Al Anbar as “militarily unwinnable,” Sheikh Abdul Sattar Albu-Risha announced the Awakening—the *Sahawa*.¹⁰ At that meeting, Sattar, along with 40 other sheikhs from the Ramadi area, signed an Emergency Council proclamation to work with the Coalition to drive Al Qaeda in Iraq (AQI) from Al Anbar. By December 2006, 18 of the 21 Ramadi-area tribes had joined this Awakening movement.¹¹ By February 2007, the movement began to accelerate throughout Al Anbar as the Coalition reinforced areas seeking help to defeat Al Qaeda. On 3 September 2007, one year after Sattar’s announcement, President George W. Bush met with the tribal leaders of Al Anbar and the leadership of Iraq to congratulate them on their successes.¹² Sattar was assassinated ten days later, but the Awakening did not stop or stall. On 1 September 2008, conditions were stable enough for the Coalition to hand over control of the province to the Iraqis.

What happened? How could Al Anbar—the cradle of the Sunni insurgency and the birthplace of AQI—turn around so quickly?

This volume and the others in the study provide trainers/educators a set of multimedia tools for use in the classroom and the field that describe the conditions that existed in the theater, what the actors perceived and how they reacted to change those conditions, and analyses of the decisions and implementation processes that contributed to the Awakening.

A. Objective

The objective of the Anbar Awakening project is to create an unclassified, credible resource for trainers and educators. It is presented in multimedia to accommodate different teaching and learning styles.¹³ The project presents the Awakening movement’s phases from development of the insurgency in 2003 to the Coalition’s transfer of responsibility for Al Anbar to the Iraqis in 2008. In addition, it offers analysis and lessons, many of which are transferrable to cur-

⁹ The Awakening movement was the Al Anbar Awakening until 2007 when two things occurred: Sheikh Sattar changed the name Al Anbar Al Sahawa to the Al Sahawa Al Iraqi, and the movement was implemented in other areas of Iraq outside of Al Anbar.

¹⁰ Thomas E. Ricks, “Situation Called Dire in West Iraq,” *Washington Post*, 11 September 2006.

¹¹ Ramadi is a city and district—in this case, those sheiks came from both the city and the district. Colonel Anthony Deane, USA, “Providing Security Force Assistance in an Economy of Force Battle,” *Military Review* (Jan–Feb 2010).

¹² Alissa J. Rubin, “Sunni Sheikh Who Backed US in Iraq Killed,” *New York Times*, 14 September 2007.

¹³ PME institutes have asked for unclassified, public releasable material to be used in their seminars.

rent and future conflicts. The ultimate product is a multimedia instructional package to accommodate different teaching and learning styles.

B. Collection

Interviews were conducted in the United States, Iraq, and Jordan, and were structured around a series of five primary research questions (PRQ) that were supplemented with secondary research questions (SRQ) that provided more granularity to the research. When answered, the SRQs addressed the breadth and depth of the project and kept it focused on the objective. None of the research questions were necessarily static; they changed as they were answered and new leads developed. Interview plans based on those questions were tailored to each interviewee. Although the final collection plan was more detailed and complex, initial PRQs and SRQs are in Table 1-1.

Table 1-1. Initial Primary and Secondary Research Questions for the Awakening Project

Primary Research Questions	Secondary Research Questions
1. How, when, and why did the insurgency start?	<ul style="list-style-type: none"> • Who participated and why did they join? • How were they supported within Iraq and/or by other countries?
2. What was the Al Anbar Awakening?	<ul style="list-style-type: none"> • Is there a single definition? If so, what is it and if not, what are the other definitions? Do different groups define it differently? • What are the various perspectives—Coalition, Iraqi, Insurgent, others? • Was there more than one Awakening?
3. What caused the Al Anbar Awakening?	<ul style="list-style-type: none"> • What events set the conditions for the Awakening? • Who and what caused those events—Coalition, Al Qaeda in Iraq, insurgents, Iraqis (residents, tribes), the Government of Iraq, Iraqi Security Forces, and others? • Was there a “tipping point?” If so, when, where, how did it start, how did it evolve?
4. How did the Al Anbar Awakening reconcile the causes identified by PRQ 3? Who and what events contributed to the reconciliation?	<ul style="list-style-type: none"> • What processes were used to reconcile the causes? • What were the strategies used by the actors to achieve their goals? • How did those strategies interact? • What resources were necessary/made available to the actors to implement their strategies?
5. What were the major themes of and lessons from the Al Anbar Awakening?	<ul style="list-style-type: none"> • Did these themes and lessons contribute to success in the larger context of Iraq? • Are they transferable to other areas such as Afghanistan or Africa? • Should they be incorporated into doctrine? • Should they be taught at the various Professional Military Education (PME) institutions? If so, how?

C. Publication Series and Structure

Creating an unclassified, credible, accurate resource for trainers and educators to examine the Awakening using multimedia is more difficult than it may sound. Constructing all of the material gathered during the interviews into a multimedia product begins where most case studies, historical analyses, and comparable projects, end: First, the case study must be completed; next (or simultaneously, if possible), the multimedia materials must be collected; and then those materials must be woven together to bring that case study to life.

That being the case, this volume is part of a multi-volume set comprising interview transcripts and a final study report, and provides a basis for the multimedia product.

D. The Volumes

The Al Anbar Awakening product consists of five volumes of reference material, comprising nine publications, plus a Teacher's Guide with an interactive, multimedia DVD. Volume I is the final report containing a storyline that follows the organization of the DVD. Volumes II–V contains the interview transcripts organized according to Coalition areas of operation (AOs). (See Figure 1-1; also, a map of the various AOs is in Appendix D.)

The volumes are organized as follows:

- Volume I. Al Anbar Awakening—Final Report
- Volume II. Al Anbar Awakening: AO Atlanta, An Overview
- Volume III. Al Anbar Awakening: AO Denver, Western Euphrates
- Volume IV. Al Anbar Awakening: AO Topeka, Ramadi Area
- Volume V. Al Anbar Awakening: AO Raleigh, Fallujah Area

Taken together, these volumes tell the in-depth Awakening story and feature all of the interview transcripts from which the storyline was constructed. As an example, Volume II covers AO Atlanta, which is approximately all of Al Anbar province. Volumes III–V cover the AOs subordinate to AO Atlanta and districts subordinate to Al Anbar.

Additionally, Volumes II–V all begin with the same introduction, PRQs, and structure to orient readers within the project and storyline, regardless of which volume they read first.

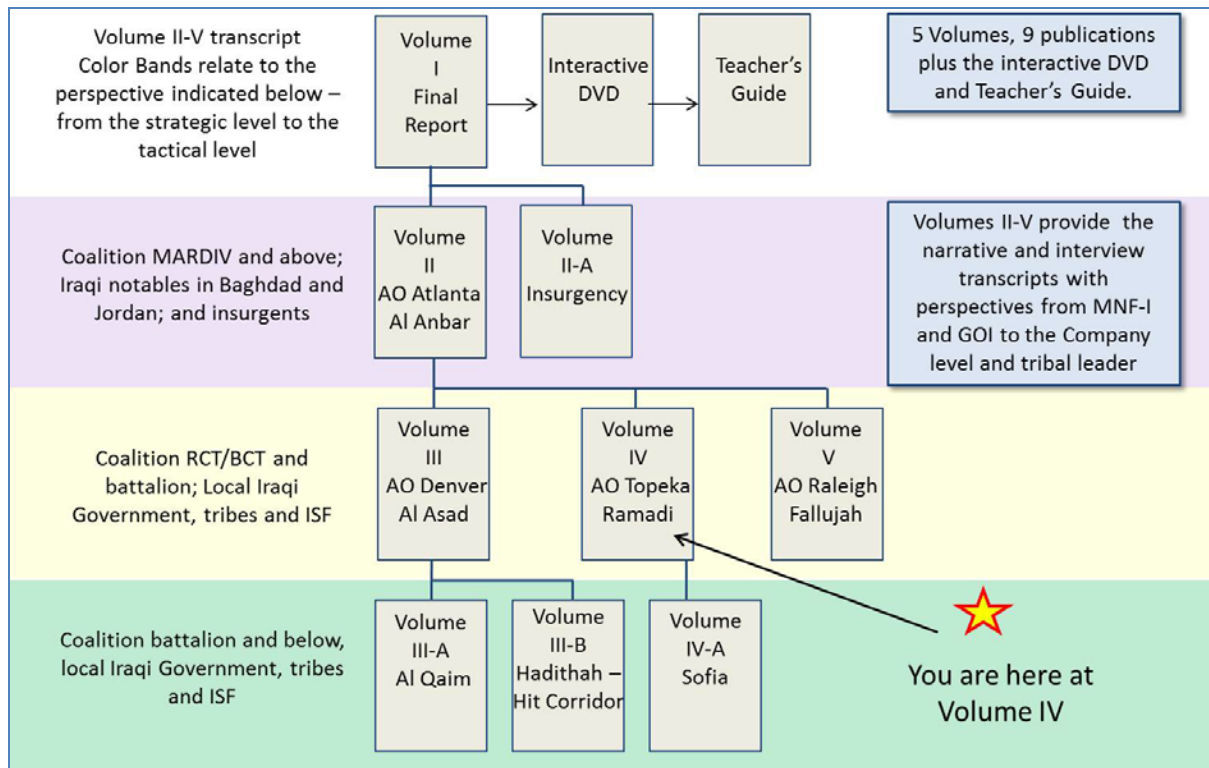

Figure 1-1. Areas of Operation in Al Anbar provide the structure for the Awakening volumes

E. This Volume

The volume you are reading (Volume IV) presents Coalition and Iraqi perspectives on events in Ramadi. Table 1-2 provides the list of Coalition and Iraqi interviewees for this publication. Their interview transcripts are provided in Appendices A and B.

Chapter 2 of this paper provides the storyline of events, responds to the research questions posed in the collection plan, and provides themes and lessons relevant to the Anbar Awakening.

Appendices include:

- A—Transcripts: Coalition Perspectives
- B—Transcripts: Iraqi Perspectives
- C—Who's Who. Name spellings and descriptions of Iraqis who appear in the document. The description includes the person's position, tribal affiliation, and some background information.
- D—Maps. Map showing areas discussed during the interviews.
- E—Illustrations
- F—References
- G—Abbreviations

Table 1-2. Transcripts appearing in Volume IV¹⁴

#	Interviewee	Position in Iraq	Interview Date
Appendix A: Coalition Transcripts			
1	BG MacFarland	Cdr, 1st Brigade Combat Team, 1st Armored Division, Ramadi, Jun 2006—Feb 2007	13 Oct 2010
2	Mr. Sterling Jensen	Interpreter, 1st BCT, 1AD and 1st BCT, 3ID, Ramadi	20 Oct 2010
3	COL Tony Deane	Cdr, 1-35 Armor “Task Force Conqueror, in Ramadi, June to November 2006	12 Oct 2010
4	MAJ Damon Mitchell	Cdr, Bravo Company, 16th Engineer Battalion	19 Dec 2010
5	CPT Stephanie Cooper	Lioness Platoon Leader, 1st Brigade Combat Team (1st BCT), 1st Armored Division (1AD)	17 Dec 2010
6	Col Bill Journey	Cdr, 1 Battalion, 6th Marines from Oct 2006 to Apr 2007	3 Mar 2010
7	Maj Jason Arthaud,	Cdr, B Company, 1st Battalion, 6th Marines in Iraq from Sep 2006 to Apr 2007	24 Mar 2010
8	Maj Daniel Zappa	Cdr, Executive Officer, 1st Battalion, 6th Marines	22 Mar 2010
9	Capt Scott Graniero	Sapper Platoon Leader, 1/6 Marines	12 Jan 2010
10	COL John Charlton	1st BCT, 3rd Infantry Division (3ID), in Ramadi from Feb 2007 until Mar 2008.	20 Oct 2010
11	COL Miciotto Johnson	Cdr, Task Force 1-77 Armor in Ramadi, Oct 2006 to Jun 2007	13 Oct 2010
12	COL William Brinkley	Cdr, 1st Engineer Battalion in Ramadi from Sep 2003 to Sep 2004	6 Dec 2010
13	COL Richard Cabrey	Cdr, 1/5 Field Artillery, in Ramadi in Sep 2003 to Sep 2004	7 Dec 2010
Appendix B: Iraqi Transcripts			
14	Mamoun Sami Rashid	Al Anbar Governor 2005 to 2006	7 Apr 2010
15	Sheikh Ahmed Albu-Risha	Paramount Sheikh of the Albu-Risha Tribe	22 Apr 2010
16	Dr. Thamir al-Assafi	Senior Theologian to the Sunni Endowment	12 Apr 2010
17	Sheikh Abdulah Jalal	Director of Sunni Endowment for Al Anbar	10 Apr 2010
18	Col Ahmed Hamid Sharqi	Chief, North Ramadi Police Precinct	7 Apr 2010

Note: The convention used throughout the study in the text is to refer to the ranks of officers, particularly American officers, during the time of deployment being discussed, corresponding to their positions indicated in the center column of Table 1-2. The references and footnotes will refer to their ranks at the time of their interview indicated in the left column of Table 1-2.

¹⁴ Coalition ranks are at the time of the interview; Coalition command positions and timeframes are in Iraq.

2. Ramadi

The insurgency was seriously damaged in late 2005 as a result of the Coalition operations targeting AQI's network in western Anbar. This provided a window of opportunity for the elements of the Sunni Arab Resistance and other nationalists to politically engage the Coalition. Despite setbacks, AQI was able to regroup in early 2006 and shifted tactics to target insurgent and tribal leaders who sought political negotiation. AQI was so successful that it recovered from its losses and became the dominant insurgent group in Al Anbar, and in Ramadi in particular. By March, AQI had eliminated much of the insurgent resistance either by murder, neutralizing its efforts, or bringing those who resisted into their fold.¹⁵

Despite its dominance in Ramadi, there was little enthusiasm among Ramadi residents for AQI. The increased criminality that AQI brought, along with its murder and intimidation campaigns, meant that AQI was more feared than loved. The tribes and local leaders that remained anti-AQI, however, maintained a low profile until their next opportunity. That would come soon.

A. The Ready First Combat Team Deploys to Ramadi

The 1st Brigade Combat Team (BCT) of the 1st Armored Division, also known as the Ready First Combat Team (RFCT) received word in May 2006 that it was going to deploy from Tal Afar to Ramadi. Although the enemy's activity in Tal Afar was not as significant as what would greet the RFCT in Ramadi, according to Colonel Sean MacFarland, RFCT Commander, "it was a pretty good dress rehearsal for what we ended up doing in Ramadi."¹⁶

There were a number of other differences that became apparent as the RFCT developed a plan for expelling the extremists from Ramadi and returning the district to its residents.¹⁷

One difference was that Tal Afar had a more diverse mix of Shia and Sunni in the area. The Coalition could generally count on the Shia being more friendly and the Sunni more hostile. The RFCT came to understand that every time a Shia tribe was befriended, an adjacent Sunni tribe could become more hostile. Per COL MacFarland:

¹⁵ Colonel Gary W. Montgomery and Chief Warrant Officer-4 Timothy McWilliams, *An-Anbar Awakening, Volume II – Iraqi Perspectives: US Marines and Counterinsurgency in Iraq, 2004–2009* (Quantico: Marine Corps University Press, 2009), 12.

¹⁶ Brigadier General Sean MacFarland, interview with Dr. William Knarr, Ft. Leavenworth, 13 Oct 2010.

¹⁷ Ramadi is a city and a district. Montgomery and McWilliams, *An-Anbar Awakening, Volume II*, 3.

You had ‘go’ and ‘no go’ areas or ‘go’ and ‘slow go’ areas in Tal Afar. You had your safe havens for us, and you had safe havens for the bad guys. You kind of knew where the demarcation line was. So when you flipped a tribe in Tal Afar, that was great, but there was always the problem of how do you get their opposite numbers on the other side of the sectarian divide to flip, also.¹⁸

By comparison, in Ramadi, they were all Sunni Arab and the whole city was hostile. So MacFarland’s question was *How do we get a toehold in Ramadi?* He felt that once he found the “key to unlocking Ramadi that approach was going to work consistently [in Ramadi]. But if we couldn’t find that key, we would have no safe areas to operate in Ramadi.” MacFarland also realized that tribes did not have influence throughout the district, and this was even less so inside the city. He would have to rely on local leaders and Iraqi forces to hold some key areas. See Figure 2-1 for tribal areas in the Ramadi district.

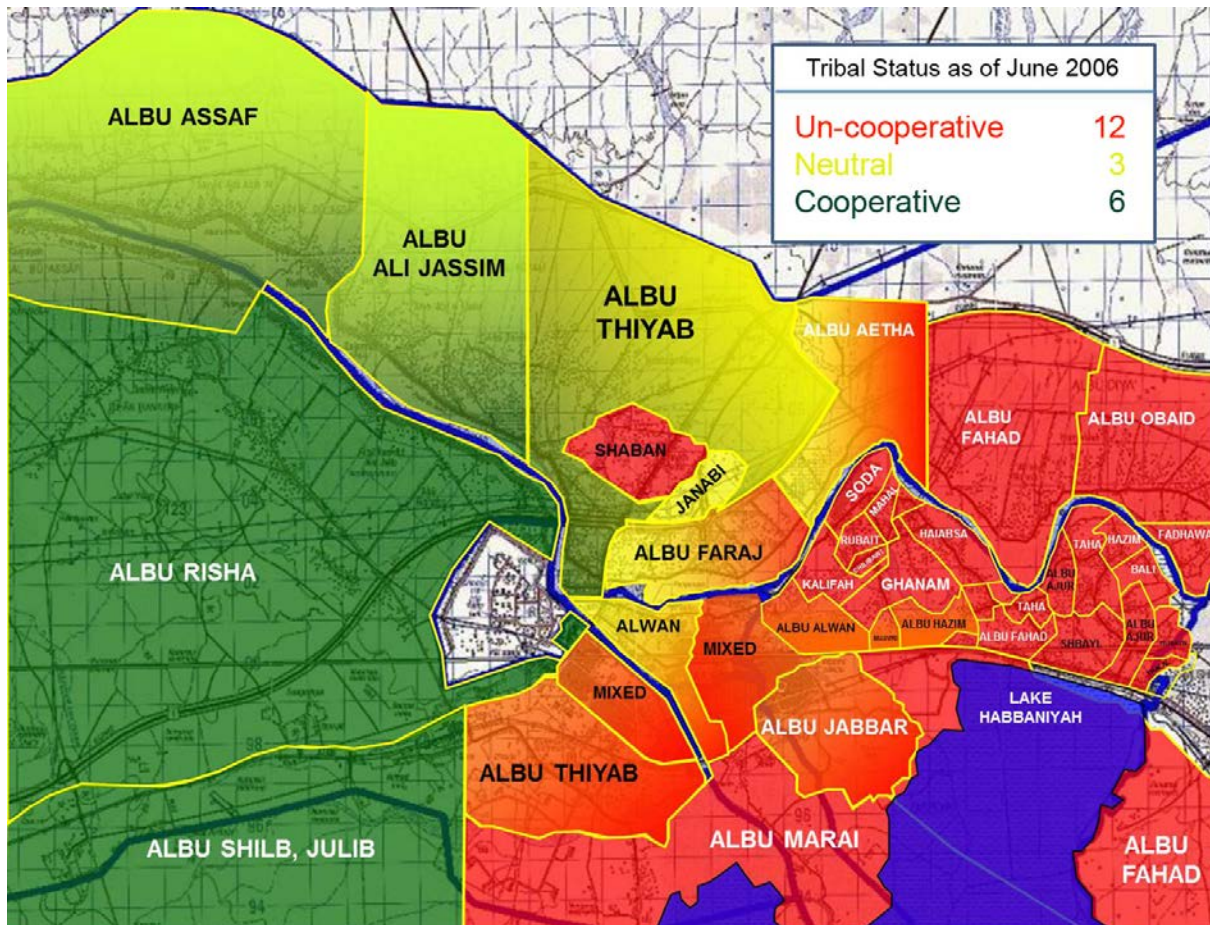

Courtesy RFCT

Figure 2-1. Status of Tribal Attitudes towards the Coalition in the Ramadi District in June 2006. The white section in the middle is Camp Ramadi.

¹⁸ MacFarland interview, 13 Oct 2010.

Another difference from Tal Afar was that Ramadi was two-to-three times larger, both in area and population; the RFCT couldn't cordon or berm the city to isolate it and clear it concentrically towards the center as his predecessor Colonel H. R. McMasters and the 3rd Armored Cavalry Regiment had done in Tal Afar. MacFarland would have to clear it neighborhood by neighborhood, west to east, and hold his gains as he moved. Using Iraqi forces in counterinsurgency was increasingly important in the Coalition's counterinsurgency campaign, and it became even more important in Ramadi as MacFarland looked at the area and population he needed to secure.

Now, because I didn't have enough forces...I knew that I had to invest heavily into the development of Iraqi Security Forces. We had a veteran Iraqi Army Brigade to the east, the 1st Brigade of the 1st Division.... I also had a brand new Iraqi Army Brigade, the 1st Brigade of the 7th Division to the west.... And I had virtually no Iraqi Policemen, so I knew I had to go out and get Iraqi Police.¹⁹

Also different was that although Tal Afar was important, in the larger campaign Ramadi was more important for several reasons. The most obvious was that it was the provincial capital of Al Anbar, and a third of all the population of Al Anbar lived in and around Ramadi.

Ramadi was also close to Baghdad. After the Coalition took back Fallujah from the insurgents during Operation AL FAJR, Ramadi became a major base of operations for the insurgents,

...where they could sortie into Baghdad or against Fallujah or down into the area south of Baghdad or up to Diyala Province north of Baghdad. So, they could influence the belts around Baghdad or they could get into Baghdad proper. Ramadi is an important location and Al Qaeda recognized this.²⁰

But the terrain in that area was also confining. Ramadi sits on a chokepoint between the reservoirs and lakes that separate Baghdad from Al Anbar Province. Additionally, major lines of communications in the form of the Euphrates River, major highways, and railroads run through the Ramadi area, and when moving from west to east, they converge before moving into the Fallujah and Baghdad areas. According to MacFarland, "If you are a foreign terrorist from Yemen, Syria, Egypt, or wherever and you wanted to get to Baghdad, you're going to probably pass through Ramadi."²¹

Just as importantly, Ramadi was symbolically significant for Al Qaeda according to MacFarland: "In essence they planted their flag there after Fallujah and chose it as the capital of their Caliphate."²²

¹⁹ MacFarland interview, 13 Oct 2010.

²⁰ MacFarland interview, 13 Oct 2010.

²¹ MacFarland interview, 13 Oct 2010.

²² MacFarland interview, 13 Oct 2010.

The RFCT moved into Ramadi with the Brigade headquarters at Camp Ramadi and TF 1-37 Armor to the south. 3rd Battalion 8th Marines (3/8 Marines) and 1-506th Air Assault were already on the ground in central and eastern Ramadi, respectively. TF 1-6 Infantry and TF 1-35 Armor would arrive from the Call Forward Brigade in Kuwait where they had been training and waiting to deploy into Iraq since November 2005.²³ This was their opportunity (see Figure 2-2).

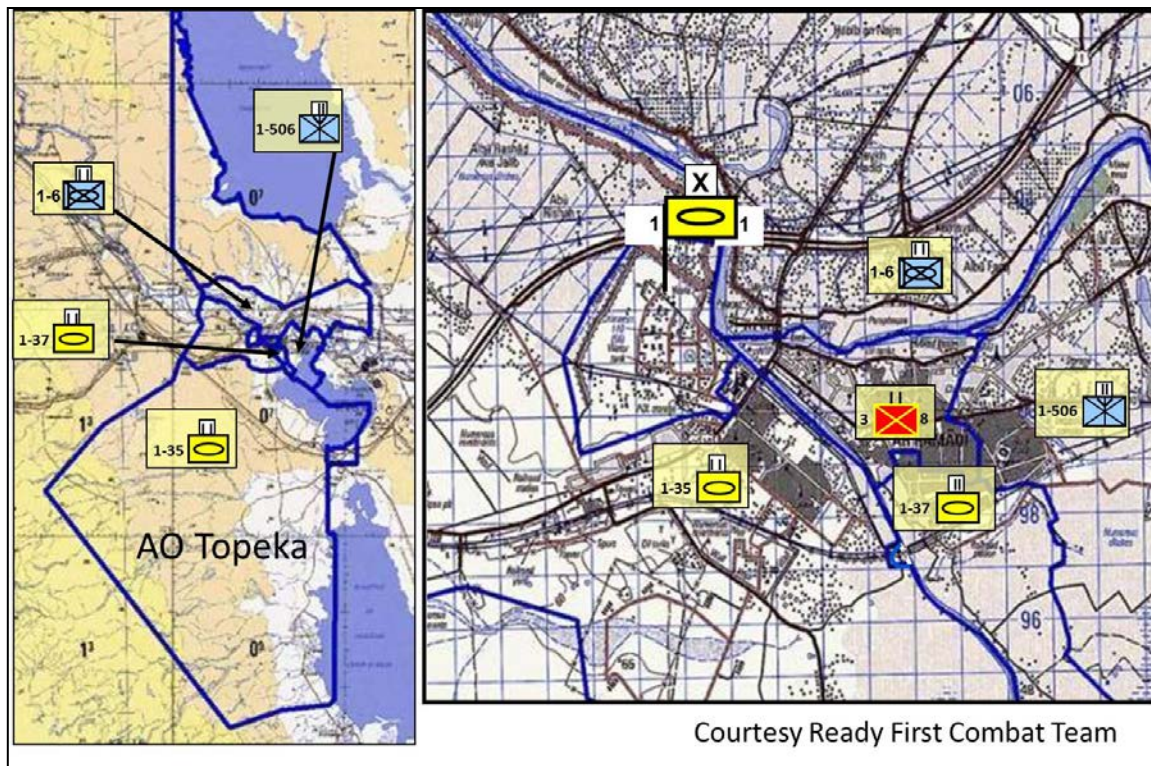

Figure 2-2. AO Topeka and RFCT's Initial Combat Maneuver Battalion Deployment

The RFCT conducted their relief-in-place (RIP)/Transfer of Authority (TOA) with the 2nd BCT of the 28th Division, a National Guard unit from Pennsylvania on 7 June 2006. On that same day, Abu Musab al-Zarqawi and his top spiritual advisor Sheikh Abd al-Rahman were killed in a Coalition airstrike north of Baquba—hopefully an omen of things to come.²⁴

²³ Deane, "Providing Security Force Assistance in an Economy of Force Battle," 81. This article goes into much more detail than this chapter's description of events for TF 1-35 Armor.

²⁴ Jonathan Finer, "How US Forces Found Iraq's Most-Wanted Man," *Washington Post*, 9 June 2006; Joshua Partlow and Michael Abromowitz, "Officials Detail Zarqawi's Last Hour," *Washington Post*, 13 June 2006.

Despite Coalition efforts to keep troop movements secret, there were rumors that the Coalition was about to start an AL FAJR-style operation in Ramadi.²⁵ AQI mid- and high-level leaders left the city *en masse* for safe havens in the Jazeerah area, the southern end of Lake Tharthar, the Hadithah-Hit Corridor, Al Qaim, and Syria. Residents also began preparing to evacuate. A number of AQI fighters remained, however, preparing improvised explosive devices (IEDs) against Coalition forces in the event a major operation commenced. Having learned from Operation AL FAJR and Operation SAYYAD II,²⁶ these fighters did not plan to confront the Coalition, but instead relied on IEDs planted throughout the city to thwart its advance.²⁷ That approach did make the Coalition's movement less confrontational, but also potentially more deadly because of the number, size, and complexity of IEDs that were used. MacFarland received guidance about how to shape the operation; it would not be like Fallujah. According to Secretary of Defense Robert Gates, MacFarland "was told, 'fix it; don't destroy it'. It was up to him, his staff and soldiers, to figure out the rest."²⁸

MacFarland's plan envisioned deliberately moving across the city from west to east, beginning in the western portion of the AO with Task Force 1st Battalion, 35th Armor Regiment (TF 1-35 Armor). In line with that plan, according to Lieutenant Colonel Lechner, RFCT Deputy Commander, there were two approaches and objectives: 1) conduct conventional operations to secure the city from AQI led insurgent dominance, and 2) build Iraqi security forces, especially police, along with a municipal structure and popular support for long term success.²⁹

But before completely settling into their AOs, MacFarland saw Zarqawi's death as an opportunity to seize the initiative. On 14 June, elements of the RFCT attacked into Ramadi from the south across the old railroad bridge in Tam'eem. MacFarland used a "swing force of three maneuver companies and an engineer company to weight the main effort" and shifted the force from one maneuver battalion to the next to confuse the enemy; to penetrate and create combat outposts (COP) within Ramadi. By the end of June, the Brigade had established four COPs in the southern and southeastern portions of the city.³⁰

In addition to taking immediate action to establish footholds in the south, the RFCT saw an immediate need in the north of the city to secure the hospital and medical university. Insurgent control of the hospital was not only a tactical problem, it presented a humanitarian crisis

²⁵ Operation AL FAJR was a large-scale Coalition and Iraqi assault on the city of Fallujah in November 2004 to rid the city of insurgents. For more information, see Matt M. Matthews, *Operation AL FAJR: A Study in Army and Marine Corps Joint Operations* (Ft. Leavenworth: Combat Studies Institute Press, 2006).

²⁶ SAYYAD II comprised a series of operations in Western Al Anbar in the summer of 2005 that targeted insurgent areas. Lieutenant Colonel Kenneth Estes, *US Marines in Iraq, 2004-2005: Into the Fray*, (History Division, US Marine Corps, 2011).

²⁷ Joshua Partlow, "Zarqawi Group Vows to Press Attacks," *Washington Post*, 12 June 2006.

²⁸ Robert Gates, Speech at the Association of the United States Army Conference, Washington, DC, 10 Oct 2007.

²⁹ LTC Jim Lechner, USA, Retired, former Deputy Commander, RFCT, 16 Jan 2014 email, "Anbar."

³⁰ COPs Iron, Spear, Eagle's Nest, and Falcon.

as the insurgents had expelled the hospital staff and shut the facility down, leaving the populace without medical care. It was during the early stages of setting the conditions in the area, both the city and its environs, that LTC Lechner assessed the status of the Ramadi police forces and tribal support. At the time, there were about 50 policemen located at two stations outside of Camp Ramadi. Although ineffective and fighting for their lives under Col Ibriham Khalil's leadership, they would provide the seed corn for what was to become a robust security force. In late summer, 3/8 Marines took back the hospital from the insurgents and established an outpost east of the hospital. This nascent police force assisted the Marines by working the civil-military issues in the area.

Because the rest of the story focuses on work at the battalion level, it is important to note that there was an effective team at the brigade that was working the ISF development and, in particular, the police efforts in conjunction with tribal engagement—they couldn't do one without the other.³¹ They would first work the suburbs to the west and northwest of the city and then, when the time was right, support police development in the city. Key leader engagement would see its first opportunities in the west and southwest of the city in Task Force 1-35 Armor's area of responsibility, primarily with the Albu-Risha.

B. Task Force 1-35 Armor

TF 1-35 Armor deployed from Kuwait to Iraq on 26 May 2006. They, along with TF 1-6 Infantry would replace Task Force 1-172 (1st Battalion, 172nd Armor, Vermont Army National Guard, a four-company battalion with an enormous AO). Although the number of Soldiers was about the same, according to Lieutenant Colonel Tony Deane, TF 1-35 Armor Commander, "now you split the problem set, you had two battalion commanders and two battalion staffs working on that same area."³² TF 1-6 Infantry would be responsible for the area north of the Euphrates and north of Ramadi city, and TF 1-35 Armor would assume responsibility for the area west and southwest of the Euphrates (see Figure 2-3). During the transfer of authority, Lieutenant Colonel Mark Lovejoy, Commander, TF 1-172, introduced LTC Deane to the various tribal leaders in the area. One of whom was Sheikh Ahmed Bezia Albu-Risha. The Bezia family had supported the Coalition for a long time and would figure prominently in the upcoming fight with AQI.

³¹ The RFCT team responsible for Iraqi Security Force development and tribal engagement was Lieutenant Colonel Jim Lechner, Deputy Commander, RFCT, Major Teddy Gates, MEF Police Implementation Officer, Captain Travis Patriquin, Brigade S9 (killed in action, Dec 2006), Captain Jason West, the S1 representative (killed in action in July 2006), Captain Mike Murphy, S3 representative and several other officers from the S3, S4 and military police. Lechner 16 Jan 2014 email.

³² Colonel Anthony Deane, interview with Dr. William Knarr, Ft. Leavenworth, KS, 12 Oct 2010.

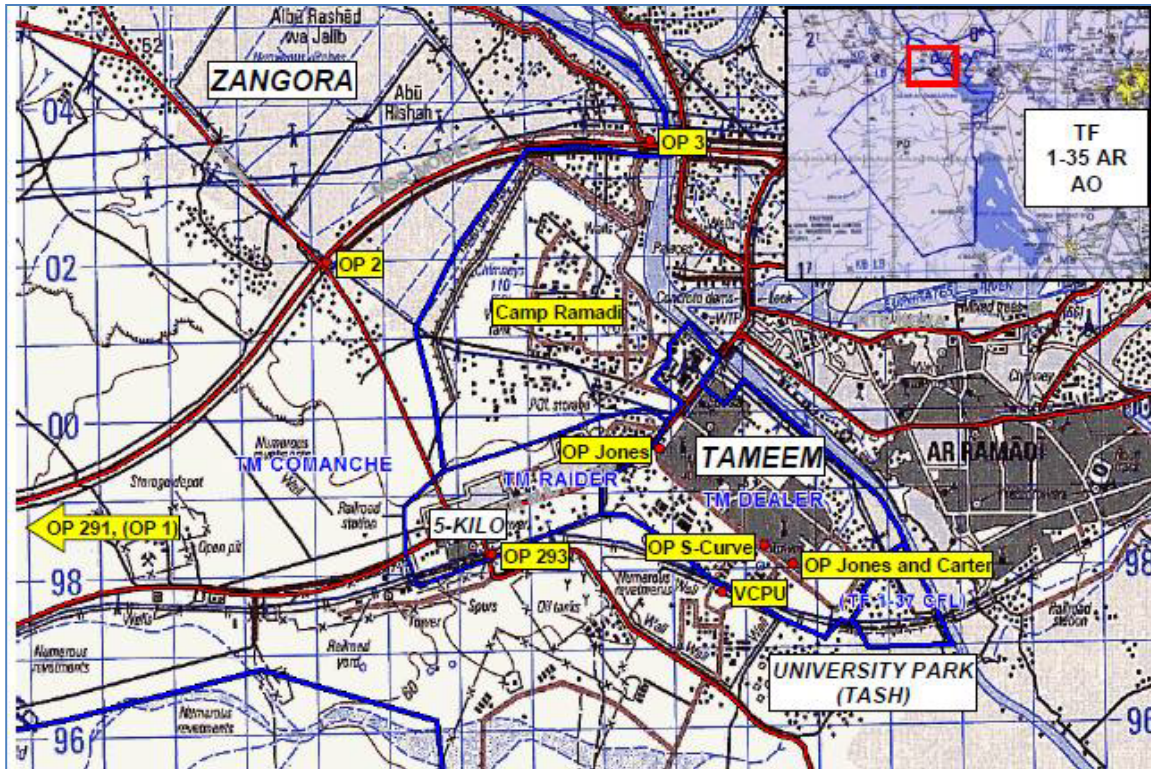

Map courtesy COL Tony Deane

Figure 2-3. TF 1-35 Armor AO

1. The fight, the fronts and the AOs

LTC Deane described his fight as an economy of force effort with two major fronts in three different AOs. Economy of force speaks for itself; according to Deane, he didn't have the assigned or attached US forces to accomplish the mission as stated. To make up the shortfall, he was expected to develop ISF, army and police, to fill the gaps and eventually take over from the Coalition. Later, Deane recognized this as a good thing:

The lack of available US combat power forced us into a close relationship with the Iraqi forces and self-generating or augmenting transition teams for each Iraqi security force unit. This support provided to the ISF would likely not have occurred if US forces had been more robust.³³

The impact and benefits of this became clearer when Lieutenant Colonel Kris Stillings, USMC, Military Transition Team (MiTT) Commander for the 1st Battalion, 1st Brigade, 7th Iraqi Army Division (1/1/7) offered, "If you give me 10 guys [to augment the MiTT], I'll give you 300 [in return]."³⁴ A deal that Deane readily accepted. In addition to having tactical con-

³³ Deane, "Providing Security Force Assistance in an Economy of Force Battle," 81.

³⁴ Deane, "Providing Security Force Assistance in an Economy of Force Battle," 81.

trol (TACON) of 1/1/7 of the Iraq Army, TF 1-35 was also supported by an Iraqi Military Police Company and Iraqi Tank Company (see Figure 2-4).

The two major fronts in this phase of the operation were the “incredibly lethal fight to wrest control of Ramadi back from Al Qaeda and the battle to link the population with the government of Iraq.”

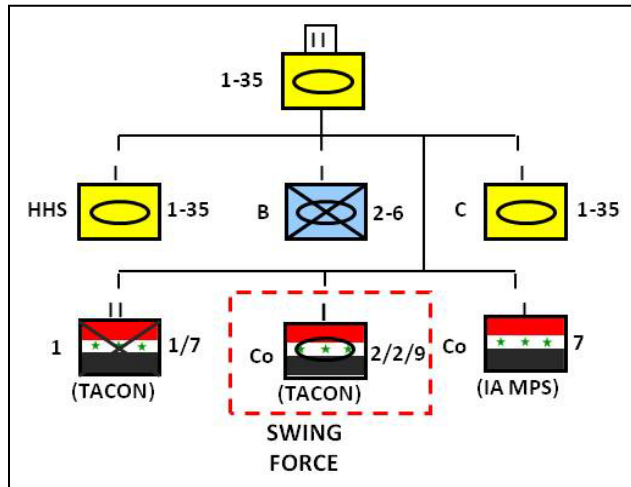

Courtesy COL Tony Deane

Figure 2-4. TF 1-35 Task Organization

LTC Deane saw his battle space as three distinct AOs. Best viewed on the map at Figure 2-3, Charlie Company (Team Comanche) was responsible (from north-west to south) for the Tribal Region of Zangora, Routes Michigan and Mobile to the west, Camp Ramadi, the desert region to the south and the Anbar University. The Zangora area itself was relatively quiet and the tribes were supportive of the Coalition.

Bravo Company, 2-6 Infantry (Team Dealer) was responsible for Tam’eem, a violent and densely populated city of 40,000.

Headquarters Company was responsible for supporting the ISF sector of 5-

Kilo.³⁵ LTC Deane described the level of violence in 5-Kilo as relatively low, but noted that this could have been the result of a lower level of population control exercised by the ISF. At times, Deane was unable to develop actionable intelligence on the area, and felt that it, under the eyes of the ISF, became a haven for Sunni rejectionists, those that rejected the legitimacy of the Iraqi Government, and possible AQI operatives.

2. Building Iraqi Security Force capacity

The second front in Deane’s two-front fight for this part of Ramadi was “...to link the population with the government of Iraq.” According to Deane:

If we can get them to join the police, then we’re not arming the tribes, because now they’re in the police and we are arming them as policemen.³⁶ Additionally, they get some training; they take an oath; they’re getting paid by the government, which is

³⁵ Extracted from Deane, “Providing Security Force Assistance in an Economy of Force Battle.” Charlie Company comprised a tank company headquarters, tank platoon, the battalion scout platoon, and the battalion mortar platoon augmented with tankers from the Battalion HHC. Bravo Company, 2-6 Infantry was a mechanized company with an attached tank platoon.

³⁶ The battalion was accused of arming the tribes; the point was that since they joined the police before they were armed, that accusation was untrue.

bringing economic benefit to the area. Since they are getting paid by the government, they now have a vested interest in the government succeeding.

The brigade and battalion commanders realized that reaching an end state of transitioning Ramadi, and subsequently Al Anbar, to Iraqi control depended on recruiting Iraqi soldiers and police forces and developing them to be able to work independently. Although there had been numerous recruitment drives in the past, simply holding events without credible Iraqi sponsorship was not working. Some of the recruitment drives were even deadly. The one that most people recall occurred on 5 January 2006 at the Glass Factory outside of the city. A suicide bomber killed 56 recruits and wounded 60 more.³⁷ All part of AQI's murder and intimidation campaign.

Deane, after a number of social visits, broached the challenges of recruiting with Sheikh Ahmed. Ahmed explained that although the candidates would go to the recruitment drives, when they got home, they were subject to AQI intimidation and would not go back. Deane suggested that they conduct the drives in the tribal areas and ship the recruits out to training on the same day, that way, Deane observed, we "... only force them to be brave once." Ahmed agreed. The first new style recruitment drive was set for 4 July 2006 at the Bezia family compound. Worried about suicide bombers, Charlie Company provided tight local security. Although suicide bombers were not a problem at this location, mortars were. AQI mortared the compound from across the river in TF 1-6 Infantry's AO. Deane rushed to Sheikh Ahmed's house, "We'll stop! We didn't mean to put your family at risk!" Ahmed responded, "Absolutely not! We are going to see this thing through." At that moment, Deane recalled, he started looking at these tribal leaders as true patriots, "It is one thing to put yourself at risk, but it's another to risk your family's life."³⁸

TF 1-35 recruited 80 police candidates that day. Less than hoped for but more than the 12 to 20 that had been recruited at previous drives. The Coalition held the recruitment drives at Ahmed's house every month thereafter.³⁹

Soon thereafter, Ahmed became absorbed with managing the family business and Deane saw less of him. Sheikh Sattar then became the principle spokesman for the tribe. Deane described Sattar:

Word on the street was "He's got a business. He might be a little bit shady. He wasn't the brains of the operation." But Sattar was there and had a lot of charisma. When he walked in the room, everybody looked at him. He was just a real, real

³⁷ Monty Morin, "Suicide Bomber Kills Dozens of Iraqi Police Recruits and Two Americans," *Stars and Stripes*, 6 Jan 2006.

³⁸ Deane interview, 12 Oct 2010.

³⁹ The recruitment drives continued with several in July and August; each one brought in a couple hundred candidates. In September, the numbers started to drop off. Deane sensed "donor fatigue"—the tribes had committed half of their able-bodied men to the police and they were in training in Jordan. The other half was needed at home to protect the families.

forceful guy. He was always immaculately dressed, robes were never dirty. And he carried chrome plated, ivory handled, Colt 45 Sesquicentennial Issue with the state of Texas on it. It was really a sight to behold.

Deane regularly met with Sheikh Sattar and, as Sattar's reputation grew, other Sheikhs joined the discussions. It was apparent that the Albu-Risha tribe was gaining in importance and expanding its contacts outside its traditional area. One of the Sheikhs who attended these meetings was Sheikh Khaled Ali Albu-Jassim (see Figure 2-5). Sheikh Khaled was instrumental in working with Col Khalid, the Ramadi Police Chief in opening the first police station in the northern suburbs along the highway in Task Force 1-6 Infantry's area. In August, Sheikh Khaled visited the Albu-Aetha tribe to the north of Ramadi to discuss rejecting AQI. AQI captured and beheaded him and held the body.⁴⁰ This murder and act of disrespect enraged the tribes; local history points to this event, more than any other, as the catalyst for the Awakening.⁴¹ Colonel MacFarland also recognized the importance of the event, calling it a "turning point."

C. Confusing Signals—the Fog of War?

On 17 August 2006, the Coalition's senior intelligence officer for Al Anbar assessed, in a soon-to-be-leaked classified report, that the Multi-National Forces and Iraqi Security Forces were "no longer capable of militarily defeating the insurgency in Al Anbar."⁴² He went on to report that the tribal system of governance and authority "wholly failed in AO Raleigh and Topeka and has only limited efficacy in AO Denver."⁴³ The only exception noted in the report was Fallujah, where the tribes still functioned despite "local politics in Al Anbar [being] anemic or dysfunctional due to insurgent intimidation...."⁴⁴

⁴⁰ Some accounts indicate that his body was left in the desert.

⁴¹ Deane, "Providing Security Force Assistance in an Economy of Force Battle"; Deane interview, 12 Oct 2010.

⁴² I-MEF G2, "State of the Emergency in Al Anbar," I MEF G-2, 17 Aug 2006, cleared for open publication 16 Dec 2010 by the Office of Security Review, Department of Defense and declassified by US Central Command Memorandum 10-012, at the request of Dr. William Knarr. Ricks, "Situation Called Dire in West Iraq."

⁴³ I-MEF G2, "State of the Emergency in Al Anbar," 1. See Appendix D for maps of various areas.

⁴⁴ I-MEF G2, "State of the Emergency in Al Anbar," 4.



Courtesy COL Tony Deane

Figure 2-5. 20 July 2006 at Sheikh Sattar's house. LTC Deane in the middle, Sheikh Sattar on the far left, and Sheikh Khaled Ali Abu-Jassim, third from left

While a number of Coalition senior leaders in Al Anbar characterized the report as basically accurate when read in its entirety, the report seemed to ignore successes in AO Denver, in particular Al Qaim, and the recent grassroots developments in the Corridor. In Ramadi, the recent tribal initiative and the nascent local militia known as the Anbar Revolutionaries promised another opportunity for organized resistance.⁴⁵ With the right mix of leadership and vision, conditions were about to improve.⁴⁶

D. *Al Sahawa*, An Awakening

On 2 September, LTC Deane met with approximately 20 Sheikhs at Sattar's compound. Unexpectedly, but well planned and researched in accordance with their constitution, they declared an "Emergency Council" enabling them to collectively partner with the Coalition to rid Al Anbar of AQI. Part of the declaration included the ouster of Governor Mamoun which they claimed was also legal under their constitution. Realizing that the impact of such a declaration exceeded the bounds of his authorities, Deane commended the council for their commitment and cautioned them that the ouster of Mamoun was unlikely to happen. Deane immediately updated COL MacFarland after the meeting and recommended he meet with Sattar.

⁴⁵ John Ward Anderson, "Iraqi Tribes Strike Back at Insurgents," *Washington Post*, 7 Mar 2006. By summer 2006, the Thuwar al-Anbar (Anbar Revolutionaries) had reformed since its earlier dissolution after the death of Lieutenant General Sa'ab Manfi al-Rawi.

⁴⁶ Ned Parker and Mohamed al-Kubacy, "Arm Tribes to Fight Al Qaeda, Say Sunnis," *The Times*, 13 Sept 2006.

MacFarland understood that Governor Mamoun was considered part of the legitimate but still fragile central government in Baghdad and the Marine Expeditionary Force's (MEF's) guidance was to work with Mamoun, rather than the tribes.⁴⁷ Additionally, the MEF leadership was also meeting with a group of senior Iraqi Sheikhs in Jordan, and felt that any engagement with local sheikhs might undermine those efforts.

MacFarland, however, was skeptical. He had been spending a lot of the time with Mamoun, and it didn't seem to be going anywhere. Furthermore, the tribes did not see Mamoun as "legitimate" and, in fact, were convinced that he was supporting AQI.⁴⁸ On the other hand, Colonel Pete Devlin, G-2 for the MEF, and others cautioned MacFarland that it was Sattar's reputation that was questionable and that Sattar might not be trustworthy. MacFarland valued Devlin's advice and understood the MEF's reluctance, but,

...somebody had thrown me a floatation device. And Pete was telling me, "Be careful, that floatation device isn't US Coast Guard Auxiliary approved, and it may not hold your head above water." I said, "Who cares. It's better than nothing." I grabbed it and it worked.

The solution came in the form of a local compromise. TF 1-35 Armor and the RFCT staff convinced the Emergency Council that if they did not pursue the ouster of Mamoun the local coalition forces would, in turn, work with them.

Despite all the cautioning, reluctance, and skepticism MacFarland encountered from higher headquarters, he met with the Sheikhs on 9 September (see Figure 2-6). He described the setting:

When I walked into the room, it was like a scene out of Lawrence of Arabia. All the tribes were represented by their sheikhs in their finest robes, and there at the front was an empty seat for me to go and sit down next to Sheikh Sattar....They plunked me right down in the middle of this and began to rattle off their manifesto, their 11 planks of their platform for the Awakening movement. They were all good, and as I've said before, had somebody asked me to write something like that, it would have been very close to what they came up with.

⁴⁷ The MEF, dual-hatted as the MNF-W headquarters, was RFCT's higher headquarters in Al Anbar.

⁴⁸ Deane interview, 12 Oct 2010.



Courtesy COL Tony Deane

Figure 2-6. 9 September 2006 meeting of LTC Deane (2nd from L), Sheikh Sattar (4th from L), COL MacFarland (5th from L), and the Ramadi Sheiks representing the Awakening Council

According to MacFarland, the key part of the Emergency Council Proclamation was “where they said that an attack on the Coalition Forces will be viewed as an attack upon members of our tribes....Within days of a tribe signing on, attacks in those areas on friendly forces would drop to zero.”

Unfortunately, in the midst of this rising tribal movement, the MEF G-2’s previously mentioned classified assessment was leaked to the press on 11 September 2006.⁴⁹ Despite the negative impact of the report on public (American) perception, skepticism over working with the tribes and mixed messages received at Multi-National Force–Iraq, the Awakening gained momentum.⁵⁰

⁴⁹ Ricks, “Situation Called Dire in West Iraq.”

⁵⁰ General George Casey, MNF-I Commander, interview with Dr. William Knarr and Colonel Dale Alford, USMC, Pentagon, 16 Dec 2010. Casey commented that the report wasn’t very helpful: “What I remember is it was an intelligence assessment without any assessment of the enemies’ weaknesses. And so there was no way to judge opportunities. It was just a very, very negative report, and it didn’t track with what a lot of the commanders were saying. So, Zilmer and I had a chat....I said, “You need to take a look at it. You need to give me your assessment of what is going on out here.”

On 14 September 2006, Sheikh Sattar publically announced the Awakening—the *Sahawa*⁵¹ (see Figure 2-7). Sattar, along with 40 other sheikhs from the Ramadi area, signed the Emergency Council proclamation to work with the Coalition to drive AQI from Al Anbar. The movement would come to be known as the *Sahawa Al Anbar*, the Anbar Awakening.⁵²

TF 1-35 continued to “clear, hold and build” in their AO—much of it made possible through their efforts to engage with the Iraqis and build ISF capacity. They conducted extremely dangerous but effective operations throughout their area of responsibility, and in particular in clearing the university (Operation TOGA) and securing Tam’eem (Operation DEALER).⁵³

Partnering with the Iraqis was progressing, and there were a number of other developments. At a news conference on 29 September 2006, COL MacFarland gave a progress report.

The last time I talked to you [14 July 2006], I told you that we were at a tipping point in the battle for Ramadi. Well, I think we’ve actually tipped. Attacks are down 25 percent over the past couple of months, and coalition forces, together with the Iraqi security forces, have steadily increased their presence inside of the city. The Iraqi police recruiting has soared tenfold, and the Iraqi army readiness has improved to the point where Iraqi army battalions are now assuming the lead in portions of the city and its suburbs.⁵⁴

Additionally, on 8 October 2006, the Iraqi Minister of Interior authorized Sheikh Sattar to take all action necessary to exterminate terrorism in Al Anbar Province, and to organize two “contingent Groups with each counting 750 members in each group in the city of Ramadi.” The contingent groups would be called Emergency Response Units. This was a sig-



Courtesy COL Tony Deane

Figure 2-7. Sheikh Sattar announces the Awakening from his compound

⁵¹ Ricks, “Situation Called Dire in West Iraq.”

⁵² *Sahawa Al Anbar* has also been referred to as the Al Anbar Salvation Council with its military wing as the Thuwar al-Anbar (Anbar Revolutionaries).

⁵³ Deane, “Providing Security Force Assistance in an Economy of Force Battle”; and Deane interview, 12 Oct 2010, provide excellent details and lessons on TF 1-35 Armor’s time in Ramadi.

⁵⁴ DOD News transcript, 29 Sept 2006, Presenter: Army Colonel Sean MacFarland, Commander, 1st Brigade Combat Team, 1st Armored Division.

nificant amount of power to bestow on Sheik Sattar, as well as an increase in authorized forces for Ramadi. Things were looking up.⁵⁵

However, despite the progress, Ramadi was still unstable. On 18 October, AQI staged a parade in Ramadi celebrating the designation of Ramadi as its Caliphate. Approximately 60 insurgents paraded along 17th Street waving AK47s, RPKs, and rocket-propelled grenades.⁵⁶ The area became a prime target for Task Force 1st Battalion, 6th Marines (TF 1/6 Marines).

E. Task Force 1/6 Marines

LtCol Journey, commander of TF 1/6 Marines, had the main effort for the Brigade. He was responsible for the center of a very dangerous city (see Figure 2-8 for area orientation). The government was under siege. Every day a contingent of Marines would escort Governor Mamoun from his house to the Government Center. On many a days, due to frequent spikes in violence, Mamoun was the only person who showed up for work.

This was not Journey's first "pump" to Iraq. He commanded 1/6 Marines in Fallujah from March to October of 2005. In Fallujah, he partnered with elements of the Iraqi Army, provided Police Transition Teams out of hide, and started standing up police stations. He employed his battalion as a Combined Action Battalion based on lessons from the Marines Combined Action Program in Vietnam. He saw that the MiTT's mission quickly exceeded the capability of the eight or nine people assigned, so he started partnering Marine platoons with Iraqi platoons and companies with companies. The focus was not on boot camp training of individuals but on employing Iraqi teams "in such a way that the supported and supporting relationship shifts to the host nation, the Iraqi Security Forces element."⁵⁷

Journey also had the benefit of talking to LtCol Dale Alford, a close friend and former commander of 3rd Battalion, 6th Marines in Al Qaim from August 2005 to March 2006. Alford had successfully "lived among the people," legitimately linked the tribes to the Iraqi Government through the "Desert Protector" program, and helped transform the Al Qaim area from an AQI sanctuary to an AQI exclusion area within seven months.

⁵⁵ Staff General Ahmed Muhammed Khalaf Al Jabburi, Deputy Assistant in the Western Area, based upon verbal order from the Minister of Interior to organize Al Anbar Police, dated 8 Oct 2006. Translated document provided by Colonel Anthony Deane, former commander 1-35 Armor. Per this order, Habbaniyah was also authorized a contingent of 750 police.

⁵⁶ Colonel John Charlton, former Commander, 1st BCT, 3rd Infantry Division, interview with Dr. William Knarr, Alexandria, VA, 20 Oct 2010, and a presentation Charlton provided during his tour in Ramadi.

⁵⁷ Colonel Bill Journey, commander of TF 1/6 Marines, interview with Dr. William Knarr, Joint Forces Command, Norfolk, VA, 3 Mar 2010.

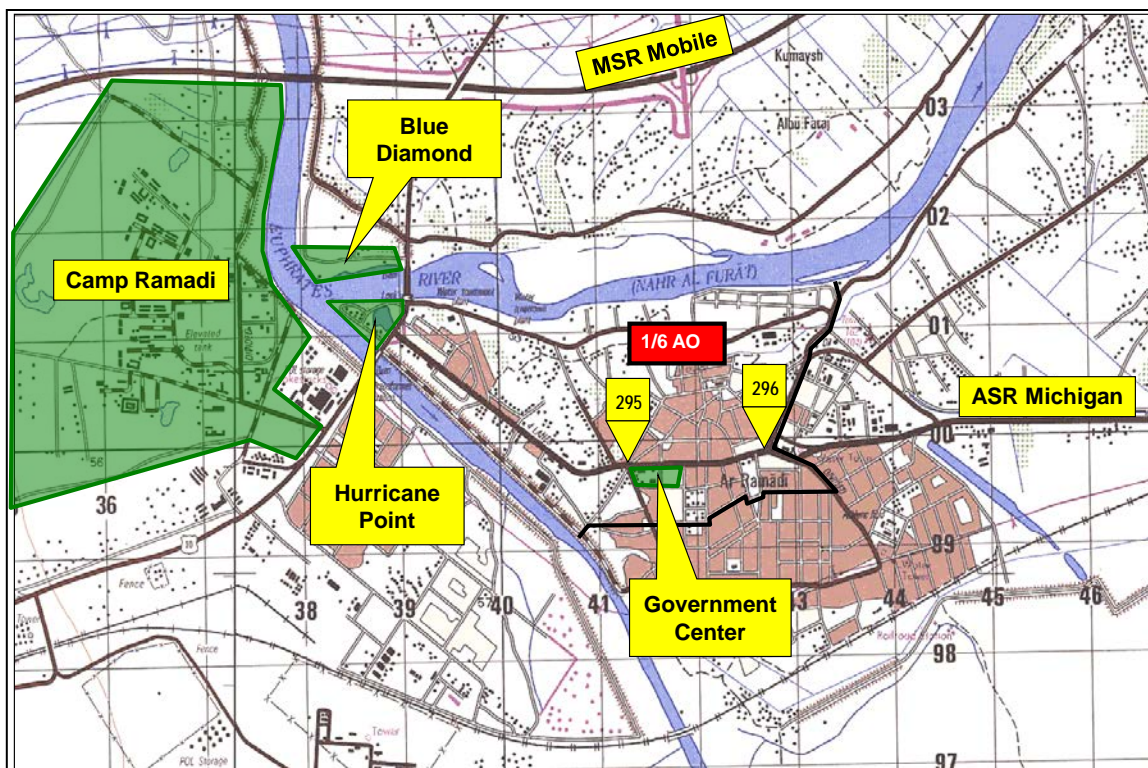

Courtesy 1/6 Marines

Figure 2-8. TF 1/6 Marines Area Orientation

In late September 2006, LtCol Journey sat down with COL MacFarland the day before their RIP with 3rd Battalion, 8th Marines (3/8) to lay out his “four-block plan...for the next 30, 60, 90, 120 days.” It was obvious to MacFarland that Journey was on track: “He was completely inside my head intent-wise. He actually took it to another level at the battalion level and instituted some really neat things there that we then used elsewhere within the brigade footprint.”⁵⁸

Journey developed three lines of operations that were complementary, mutually supporting, and executed concurrently:

- Neutralize anti-Iraqi elements and criminal threats to improving security and stability.
- Train, employ and operate in coordination with partnered Iraqi Police and Iraqi Army.
- Conduct and support civil-military operations/information operations efforts that develop the local populace’s trust and confidence in the abilities of their elected leaders and ISF.⁵⁹

⁵⁸ MacFarland interview, 13 Oct 2010.

⁵⁹ LtCol William Journey, *1st Battalion, 6th Marines Ramadi Overview*, presentation, received 3 Mar 2010.

1. Taking back the city

The situation facing TF 1/6 Marines was simple: the insurgents owned the center of the city; except for the Government Center, there was no permanent ISF presence in the heart of the city. The Marines' partnership battalion, the 2nd Battalion of the 1st Iraqi Brigade of the 7th Iraqi Army Division (2/1/7) was working on the problem from the "outside-in." That is, the battalion was located at Camp Ramadi with a company and outposts in the northwest sector of the city. In partnership, the new combined task force needed to start working "inside-out."

To create maneuver room, Journey had to "move the violence away from the Government Center." His plan was to seize a piece of terrain away from the Government Center as a starting point for expanding into the city. He chose a building on 17th Street, the street used by AQI to celebrate its new Caliphate. On 27 October 2006, ten days after the AQI celebration parade, 1/6 Marines with their Iraqi partners executed Operation BELLEAU WOOD to plant the first Iraqi Security Station (not called a combat outpost) in the heart of the city and in the heart of insurgent-controlled territory—a bold move that no doubt shocked the insurgents. Plus, they made it clear, the Iraqi and Coalition forces weren't leaving! (See Figure 2-9; the 17th Street Security Station is in the white circle. Use CP 295 to relate it to Figure 2-8).

Journey immediately established a contingent of Iraqi military at the new Security Station, but he needed police. Although Sheikh Sattar was coming through on his commitments to provide police recruits, those tribal members were not necessarily going into the city to be policemen. Some of them worked on the outskirts of the city at the West Ramadi Police Station, but they did not venture too far from their local police station. According to Journey, the value in local police is that they needed to come from the local area; in this case, from within the city center itself.

Colonel Ahmed Hamid Sharqi, who had been with the Ramadi Police since its inception, accompanied Journey to the Jazeerah area to link up with 20 Jordan-trained IPs who were supposed to support the Ramadi Station.⁶⁰ However, the new IPs refused to go to Ramadi and were supported by the Jazeerah tribal leader who told Ahmed that everyone was responsible for "cleaning up their own mess." Ahmed responded, "Ramadi is not a specific area for one tribe; it's a mix from everybody; we need the help of everybody!" However, he argued to no avail. Colonel Ahmed and Journey left with no police and no support from Jazeerah. As Colonel Ahmed recalled, "The Marines told me after the meeting, 'Forget about it Colonel Ahmed. Don't worry; we are your tribe now.'"⁶¹

⁶⁰ Colonel Ahmed Hamid Sharqi, Police Chief of the North Ramadi Police District, interview with Dr. William Knarr and Colonel Dale Alford, USMC, North Ramadi Precinct, 7 Apr 2010.

⁶¹ Sharqi interview, 7 Apr 2010.

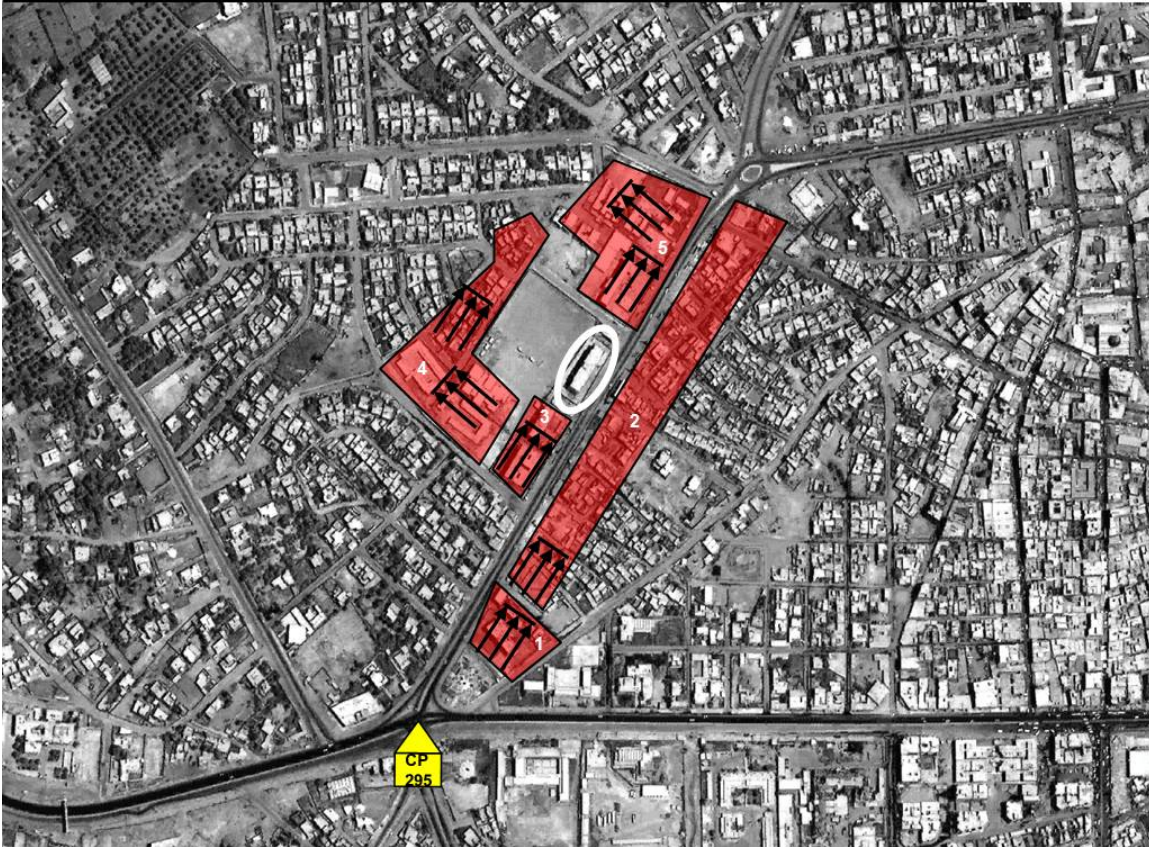

Courtesy 1/6 Marines

Figure 2-9. 17th Street Security Station in the middle of AQI-held territory in the center of the city seized and held by 1/6 Marines during Operation BELLEAU WOOD⁶²

2. Developing the police

While attempting to bring in police from surrounding areas, Journey had been working with the Governor to identify police candidates within the city. Journey noted that Mamoun, despite his own personal security issues and understanding the need for a police force, had not been too helpful overall. But one day Mamoun, quite unexpectedly provided the names of 120 candidates from the city “that had been vetted and screened.” Journey and his TF did not waste time “...within 24 hours we built a police station for them with 24/7 Marine presence. That was the Al Warar Police Station [located about a kilometer west of OP 295 along Route Michigan] which was absolutely the turning point for follow-on combined actions within the city.” Mamoun also nominated the police chief, Lieutenant Colonel Salam al-Alwani, an incredibly “brave and dedicated Iraqi.”⁶³ This was bad news for the insurgents. According to Journey, “A

⁶² Extracted from 1/6 Marines Operation BELLEAU WOOD Concept of the Operations.

⁶³ Journey interview, 3 Mar 2010.

local security force is an insurgent's worst nightmare because they know who the bad guys are....This was not going to be a good news story for the enemy."⁶⁴

At the time, the TF only had one Coalition police transition team from the National Guard, located at the West Ramadi Police Station. In order to embed stations throughout the city, they needed to develop augmentation teams out of hide to partner with the developing police stations and substations. The first would be assigned to the new Al Warar Police Station and then to the previously built 17th Street Security Sub-station.

As noted earlier, higher headquarters tended not to notice the bottom-up change in Al-Anbar, and the press even less so. Just as TF 1/6 Marines was bringing a permanent Iraqi and Coalition presence to the heart of what the insurgents had just declared their capital, a *Washington Post* article entitled, "Anbar Picture Grows Clearer and Bleaker," cited a mid-November updated version of the 17 August 2006 classified report indicating there had been no improvement, and no improvement was expected in Al Anbar security conditions.⁶⁵

F. TF 1/6 Marines: The Third Line of Operation

As Journey's lines of operation were to be developed and executed concurrently, Major Daniel Zappa, the TF 1/6 Marines executive officer was responsible for developing the third line of operation, doctrinally referred to as Civil-Military Operations and Information Operations. Three essential team members were Mr. Adel Abouhana, Cultural Advisor to the TF commander; Lieutenant Colonel Salam al-Awani, the local police chief; and Captain Scott Kish, the TF Civil Affairs Officer. One of the initiatives, dubbed "Voice of Ramadi," was to use speaker systems, like those in the mosques, to broadcast their message to the population. At first, mobile systems were used, but eventually, static broadcast systems were set up at all the IP Stations. Adel sought IP officers with strong charismatic voices and developed and broadcast messages relevant to the local communities. Some of the messages explicitly thanked the community "for the information that you are providing on the insurgents." This technique served to plant seeds of doubt in the minds of the insurgents.⁶⁶

But a credible message needed more than broadcast and leaflets, it needed deeds to show it was effective. Those deeds came in the form of increased security and better living conditions such as trash removal (in this case, including clearing destroyed cars and rubble).

⁶⁴ Journey interview, 3 Mar 2010. LtCol Journey provided a great account of his first sit down discussion with the Shia Iraqi Army Battalion commander and LtCol Salam, the Sunni Police Chief to address all the potential issues that they as leaders needed to be prepared to address. See transcript in Appendix A, Volume IV of this project.

⁶⁵ Dafna Linzer and Thomas Ricks, "Anbar Picture Grows Clearer and Bleaker," *Washington Post*, 28 Nov 2006.

⁶⁶ Major Daniel Zappa, former Executive Officer, 1st Battalion, 6th Marines, interview with Dr. William Knarr, Marine Corps University, 22 Mar 2010.

G. The Engineer's Contribution

As TF 1-6 Marines moved from west to east, one of the more challenging projects for the engineers was the Qatana Police Station. Beginning 18 December 2006, Operation HUE CITY set out to construct a station on the northeast corner of Racetrack (see Figure 2-10). Unfortunately, the insurgents knew that the area was prime real estate for an IP station and got there first to rig it and most of the nearby buildings with explosives before TF 1-6 arrived.

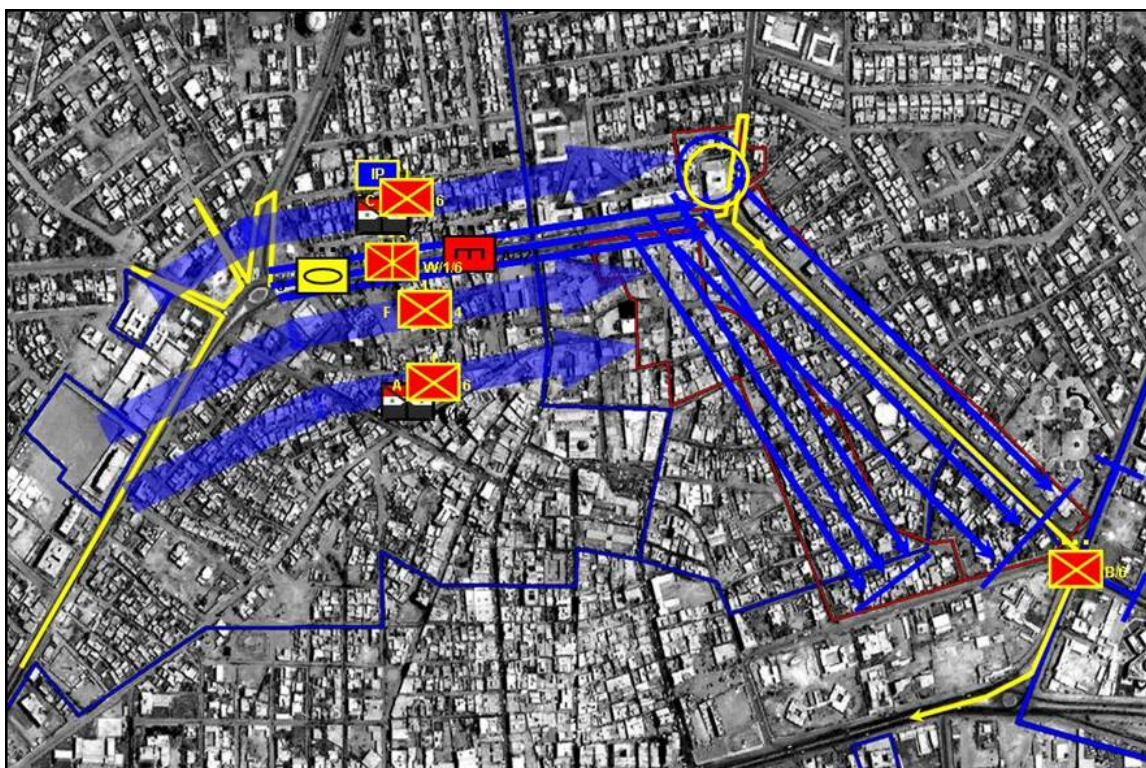

Courtesy 1/6 Marines

Figure 2-10. Operation HUE CITY's aim was to construct the Qatana IP Station in the northeast sector of Racetrack (yellow circle)

Lieutenant Scott Graniero, Sapper Platoon leader for 1/6 Marines, planned to construct the station in one of several buildings on the north side of Racetrack. His primary choice was the old Iraqi Sanitation building (also circled in yellow in Figure 7-10). Graniero explains his rationale:

The Sanitation building provided the most observation down all the avenues of approach that we were looking to cover. It was also probably the tallest of the three buildings in that area. And in an urban environment it's always good to be in a build-

ing that's taller than the other buildings around you, because nobody likes to be shot down on by the enemy.⁶⁷

As the route clearance progressed and the infantry cleared the areas north and south of Racetrack, the engineers emplaced barriers along all the major intersections. According to Graniero, "our biggest fear was that they were going to run a VBIED up into our work area from the side, so we blocked off those intersections." The engineers arrived and occupied the Sanitation building at 0600, barrier materials followed at 0700, and by 0900 the Marines were building the perimeter and fortifying the building.

The smooth beginning to the operation did not last. What began as small arms fire, quickly escalated into a devastating IED attack. Graniero described events beginning at 0930:

I walked into the building to tell the Marines to get up and to start moving sandbags into the building and that is when the IED was triggered on us.... It was really chaotic, nobody knew what was going on inside the building because we were just standing there and the next thing you know the building blows up underneath our feet....We had about ten casualties, mostly guys from Charlie Company, 1/6...we CASEVAC'd them back.

Immediately following the IED attack, the platoon took mortar fire including two effective hits resulting in another ten casualties. "This is when we realized that this building was no longer going to be used as the OP."

Finding the position untenable, Graniero's platoon repositioned. By 1200, they had occupied the former Oil Ministry Building in the same area. The Marines quickly established perimeter security positions and started to fortify that building. At about 1800 they were unloading a recent resupply of meals ready to eat (MRE), when, according to Graniero:

As the Marines were moving the MREs in, they were just tossing them off to the side and one of the Marines had happened to grab a case of MREs threw it, hit the side of the wall, kind of exposed the wood panel open a little bit. Another Marine sees wires running up and down this wall and goes, "What the heck is that?" We then grab flash lights, look behind the wall and as we peel it back we see the 155 rounds double stacked on top of each other nose to nose and with the blasting caps inside the fuse wall. [See Figure 2-11]

⁶⁷ Captain Scott Graniero, interview with Dr. William Knarr, Camp Lejeune, 12 Jan 20120.

Graniero realized that this, and probably other nearby buildings were also rigged and that they had to get out. They moved west down Racetrack toward the Firecracker IP station on the corner and spent the night.

The next day, Graniero deployed his platoon back to Camp Ramadi and linked up with the 16th Engineer Battalion to re-plan the siting and construction of the Qatana Iraqi Police Station. This demonstration of insurgent determination and capability to deny the center of Ramadi to the Coalition complicated the challenge of establishing the police station. The building that was finally selected was one of the shortest ones in the area because it was the only one there determined to be clear of IEDs.

With weeks the Qatana Police Station was manned, but it took several months to complete it.

To the east of TF 1/6 Marines was Task Force 1st Battalion, 9th Infantry (TF 1-9). As TF 1/6 moved west to east, TF 1-9 unexpectedly took a different tack and started from the eastern part of their AO to the west, or as the Task Force commander described it, “eating the donut from the outside in.”

H. Task Force 1st Battalion, 9th Infantry Regiment

TF 1-9, commanded by Lieutenant Colonel Chuck Ferry, arrived in East Ramadi in October 2006. TF 1-9’s mission was to secure East Ramadi and, specifically, the Mula’ab area first and later the eastern sectors of Sofia and Julaybah (see Figure 2-12).

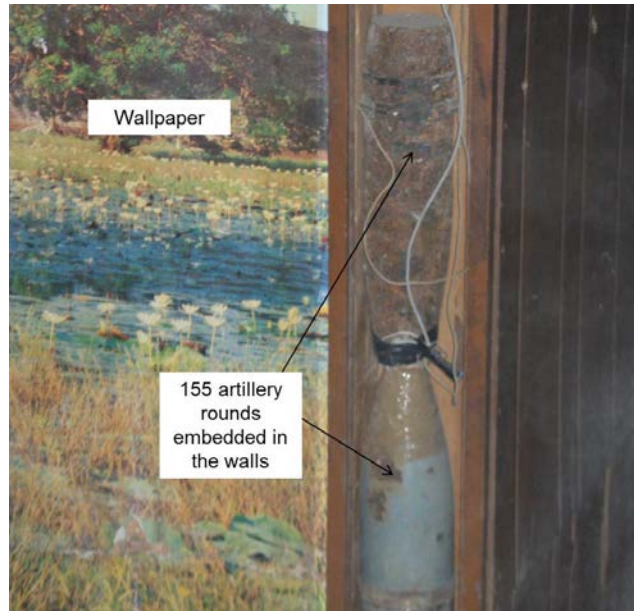

Courtesy 1/6 Marines

Figure 2-11. Insurgents rigged buildings to detonate when Coalition forces entered

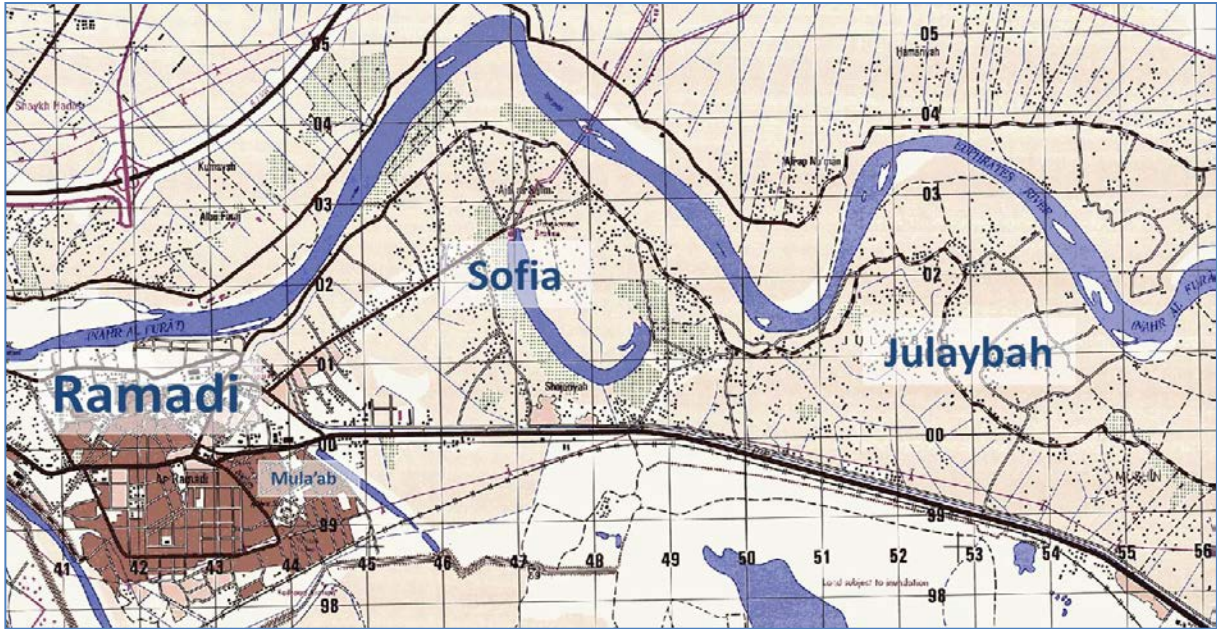

Figure 2-12. TF 1-9 AO, the Mula'ab section of East Ramadi and east through Julaybah

However, AQI's vicious attack on Sheikh Jassim and the Abu-Souda tribe in Sofia on 25 November reprioritized TF 1-9's missions into what Ferry would describe as "eating the donut on the outside first." Instead of directly striking AQI in the Mula'ab area—the center of the "donut"—he attacked AQI's sanctuary in the shark fins area to the east.⁶⁸ This minimized AQI's capability to resupply or reinforce the Mula'ab area. The subsequent fight for the westernmost shark fin, Sofia, has been described by MacFarland as another major turning point in the battles for Al Anbar. One indicator of the critical nature of this fight was that at a time when all Coalition forces seemed stretched to the breaking point, TF 1-9 received a plus-up of two companies from 2/4 BLT of the 15th Marine Expeditionary Unit. According to MacFarland, GEN Casey saw an opportunity to "reinforce success" and additional troops were what TF 1-9 needed to accomplish the mission both in Julaybah, the eastern-most Shark Fin, and then in the Mula'ab. Due to its role, TF 1-9's story is told in its own volume of this Awakening series, Volume IV-A.

⁶⁸ See Figure 2-12. The Shark Fins define an area to the east of Ramadi where the profile of the Euphrates on the map resembles two shark fins, one at Sofia and the other at Julaybah.

I. Other Iraqi Leaders Who made a Difference

Security and ISF capacity continued to progress in Ramadi. However, to be effective and to endure, building Iraqi capacity had to be more than a bumper sticker. A number of Iraqis stepped forward to take the lead, knowing they were putting themselves and their families in jeopardy. Most people know of Sheikhs Sattar, Ahmed, Jassim, and others in the Awakening Council. But there were a number of Iraqis outside the tribal leadership affiliation who stepped forward. According to LTC Lechner, Col Khalil was the original Ramadi police chief dedicated



Figure 2-13. Colonel Ahmed Hamid Sharqi

to building an effective force throughout the Ramadi area, starting first in the suburbs with two IP stations and a handful of police to over 5,000 and 25 IP stations in February. Instrumental in establishing the police in the city was LTC Salam al-Awani. According to Maj Zappa, LTC Salam was a “fire breather, he was awesome.” He was the first chief of police in Ramadi and the initial “Voice of Ramadi.” Unfortunately, he was killed in early 2007 by a vehicle-borne improvised explosive device.

Another courageous Iraqi stepped up to take his place—his cousin, Colonel Ahmed Hamid Sharqi. Col Ahmed was relentless in the fight against terrorism and became known as the “Hatchet Man” (see Figure 2-13). Col Ahmed used an axe to break down doors. Soon after, rumors spread about him using the axes to cut off terrorists’ heads. Col Ahmed insisted it wasn’t true, but added that it probably didn’t hurt if the insurgents believed it to be so.⁶⁹

J. Continued Progress in Ramadi

By December 2006, 12 of the 21 Ramadi-area tribes were cooperating with the Coalition and six more were neutral (see Figure 2-14. Status of Tribal Attitudes towards the Coalition in the Ramadi District in December 2006. The white section in the middle is Camp Ramadi.) This was a total turn-around in the number of tribes classified as cooperative, neutral or uncooperative since the June assessment.

⁶⁹ Sharqi interview, 7 Apr 2012, and Alex Kingsbury, *US News and World Report*, “In Iraq, US Marines Rely on Allies Like a Hatchet-Wielding Colonel to Keep the Peace,” 30 Oct 2008.

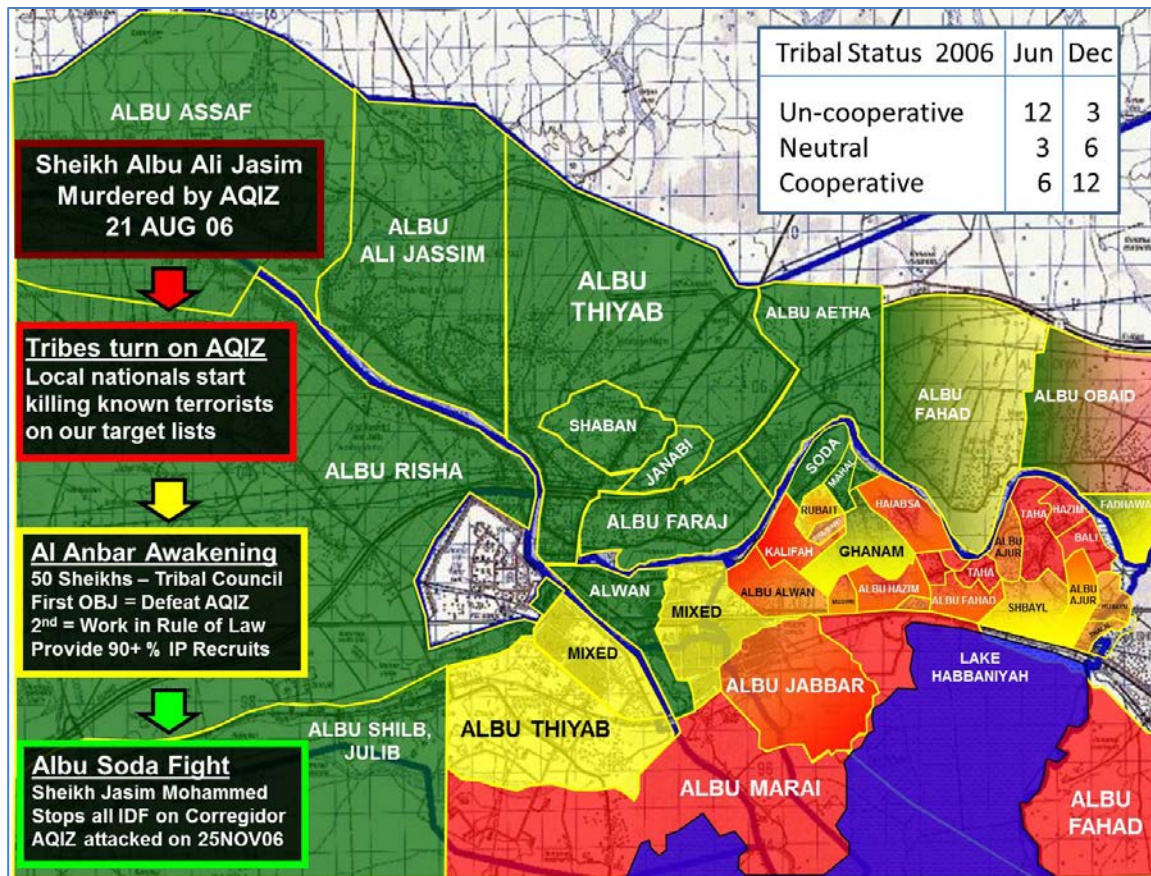

Courtesy 1/6 Marines

Figure 2-14. Status of Tribal Attitudes towards the Coalition in the Ramadi District in December 2006. The white section in the middle is Camp Ramadi.

COL MacFarland’s RFCT continued to expand its tribal engagement efforts. Despite the successes, there were several notable hard cases. The Albu-Alwan, located in west Ramadi and an area to the east of the city, was one of them. Despite Governor Mamoun’s affiliation with the tribe, they were one of the last to openly support the Coalition. According to MacFarland,

When the Alwanis came into the Awakening, Sattar said to me, “This is the beginning of the end for Al Qaeda. It’s all over now. Now that the Alwanis are with us, they can’t stop us, because now we have a secure part of the city to operate in.”

The other tribe that posed a significant challenge was the Albu-Fahad, located both north and south of the river, to the east of Ramadi city. According to MacFarland (and reflected in Figure 2-15), the northern clans were friendly but elements of the tribe to south were major AQI supporters, until TF 1-9 gained a foothold in the Julaybah area. According to LTC Ferry, Albu-Fahad members were well-educated and relatively well-off thanks to several tribe-owned construction companies. According to COL John Charlton, Commander, 1st BCT, 3rd Infantry Division, known as the “Raiders,” the unit that replaced the RFCT, Sheikh Sattar’s

influence had grown tremendously, and during their initial engagement with the Albu-Fahad leadership Sattar was treated like a “rock star.” The clincher, according to MacFarland, was the Albu-Fahad’s participation in the Ramadi Reconstruction Conference.

Establishing security, winning the confidence of the people, and developing ISF capacity all continued to improve throughout Ramadi and Al Anbar. The next major step was economic development. MacFarland was concerned that there may be a lag in economic development as security stabilized. The Iraqis would expect continued improvement and any lag or gap could offer AQI an opportunity. The first Ramadi Reconstruction Conference was held in January 2007. Not just for those areas in Ramadi in a position to benefit from reconstruction efforts, but also to show those in the embattled neighborhoods that joining the Awakening would bring tangible rewards. The first conference was held in Sheikh Sattar’s home and included local sheiks, local government officials, and contractors such as members of the Albu-Fahad tribe.

K. The 1st Brigade Combat Team, 3rd Infantry Division

The first development conference also served as a handover of sorts. COL Charlton, the incoming commander, attended the conference with MacFarland. Charlton wanted to sustain gains the RFCT had made and, in fact, scheduled the first brigade operations to coincide with the end-of-April RIP/TOA between the two units. In addition, he wanted to deny the insurgents the ability to sense any gaps in activity as a result of the changeover of units. To ensure that, the new brigade scheduled back-to-back battalion operations, titled “Secure the population and clear Ramadi” to keep the insurgents off-balance (see Figure 2-15).⁷⁰

⁷⁰ Charlton interview, 20 Oct 2010, and a presentation he provided on his work in Ramadi.



Courtesy COL John Charlton

Figure 2-15. Clearing Operations in Ramadi

1. Operations in Ramadi

The new operations gave TF 1-9 Infantry the opportunity to turn away from the Shark Fins and eat the “inside of the donut.” The operation in Mula’ab, dubbed Operation MURFREESBORO, was scheduled for 18 February to 10 March 2007. COL Charlton described this area as the “worst of the worse.”

The second operation—OKINAWA—was planned for central Ramadi by TF 1/6 Marines and conducted from 9–20 March. The last was Operation CALL TO FREEDOM conducted by TF 3-69 Armor in south Ramadi from 17–30 March.

The near continuous operations fragmented AQI in Ramadi. Their sources of manpower and resources in the eastern areas of Sofia and Julaybah were locked down, and now the Coalition and the Iraqi forces controlled their so-called Caliphate in Ramadi. The remnants of AQI fled to the Tharthar area, east to the Fallujah District, and into Baghdad.

Evidence of the general success of operations in and around Ramadi is manifest in the precipitous drop in violence there. The reduction in daily attacks in AO Topeka from 18 February 2007 when they assumed the mission, to May 2007 was simply incredible (see Figure 2-16).

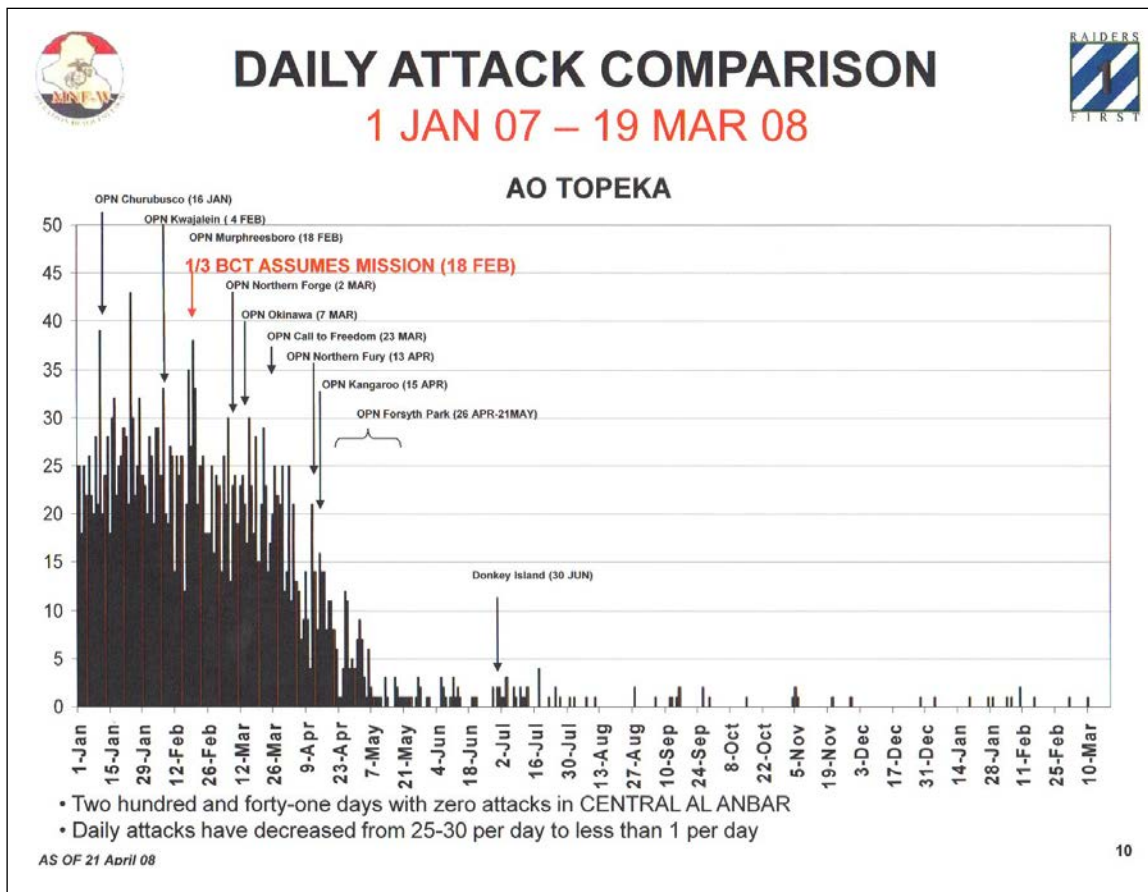

Courtesy COL John Charlton

Figure 2-16. Daily Attacks in AO Topeka from 1 January 2007 to 19 March 2008

2. Lake Tharthar region

By late Summer 2007, the security situation in TF 1-9's AO was considered excellent. It was so good, in fact, that the unit was tasked to conduct several air assault operations in Tharthar region to the north.⁷¹ Additionally, battalions of the 1st Brigade, 1st Iraqi Army division assumed control for battlespace in the Ramadi area as well as locating a battalion in the Tharthar region in the late summer of 2007.⁷²

⁷¹ Lieutenant Colonel Charles P. Ferry, Memorandum for Record, Subject: Summary of Task Force 1-9 IN Combat Operations from 6 Nov 2006 to 1 Dec 2007, 2.

⁷² Brigadier General Adel Abbas, Commander 1st Brigade, 1st Iraqi Division, interview with Dr. William Knarr, Colonel Dale Alford, USMC, and LtCol David Graves, USMC, his office in Ramadi, 8 Apr 2010.

3. Economic developments

Charlton and his “Raiders” kept the pressure on AQI by increasing security, ISF capacity, and economic opportunity. But economic opportunities require more than reconstruction. According to Charlton, it is the “second economic layer”—things like an “entrepreneurial spirit,” getting the *souqs* (markets) up and running, expanding the bakeries, opening the business centers, developing skills training—that is the key. Then it’s the manufacturing and the big employers: glass and ceramics factories and others that can take hold and serve as an engine to economic development and expansion. After a while, the society can be self-sustaining.⁷³

4. A sustained movement

By early 2007, the movement began to accelerate throughout Al Anbar as the Coalition reinforced areas seeking help to defeat Al Qaeda. On 3 September 2007, one year after Sattar’s announcement, President George W. Bush met with the tribal leaders of Al Anbar and the leadership of Iraq to congratulate them on their successes.⁷⁴

As if to drive home the point that freedom from the tyranny of terrorists comes at a price, Sattar was assassinated ten days later. By then the Awakening was essentially self-sustaining; a tribute to all of his work. On 1 September 2008, conditions were stable enough for the Coalition to hand over control of the entire province to the Iraqis.

L. Themes and Lessons

Each volume in this study provides themes corresponding to significant events in each AO. Below are the themes and leads gleaned from the events that occurred in Ramadi; events that were significant and similar or dissimilar to other areas of Al Anbar are also noted.

1. The experience of the Coalition force was extraordinary!

According to COL MacFarland, 40–50% of the brigade were veterans from the brigade’s previous deployment, and with new folks who had previously deployed with other units, the brigade consisted of more than 50% veterans.

About 35% of LTC Ferry’s 1-9 Infantry had served during its deployment as 1-503 AA, and approximately 70% had served previous combat tours. All of the company commanders had previous combat tours and all had come from the Ranger Regiment or the Ranger Training Brigade.⁷⁵

⁷³ Charlton interview, 20 Oct 2010.

⁷⁴ Alissa J. Rubin, “Sunni Sheikh Who Backed US in Iraq Killed,” *New York Times*, 14 Sept 2007.

⁷⁵ Ferry interview, 8 Nov 2010. Additionally, this was Ferry’s and Bergmann’s fifth combat tour. Bergmann had served multiple combat tours in Afghanistan and Iraq and had jumped into Panama with the Ranger Regiment. Ferry served a combat tour in Mogadishu as a young lieutenant (during the “Black Hawk Down” battles) plus multiple tours in Iraq and Afghanistan with the Ranger Regiment.

LtCol Journey commanded 1/6 Marines in Fallujah from March to October of 2005. He deployed that battalion of veterans one year later to Ramadi.

2. The benefits of a dress rehearsal

The RFCT received word in May of 2006 that they were going to deploy from Tal Afar to Ramadi. Although the enemy's activity level in Tal Afar was not as high as it would be in Ramadi, according to COL Sean MacFarland, RFCT Commander, "it was a pretty good dress rehearsal for what we ended up doing in Ramadi."

3. Not all Awakenings are the same

The evolution of events in the Ramadi area illustrates that not all awakenings are the same. Typically, people associate the awakening with the tribes, but in some cases such as in the city, there were no dominant tribes or tribal leaders willing to take charge. In Ramadi, for example, the local leader who took charge was initially LTC Salam al-Awani, Chief of Police. When he was assassinated, Col Ahmed Hamid Sharqi took charge.

This also occurred in Hadithah. As Abd al-hakim Muhammad Rashid, the mayor of Hadithah indicated, "there was no popular militia to fight the *sahawa*" in Hadithah as there was in Al Qaim or Ramadi.⁷⁶ Baghdadi's awakening was also different in that a courageous Iraqi, Colonel Shaban Barzan Abdul Himrin Al-Ubaydi went home to Baghdadi and decided to organize a police force to fight AQI.

4. Combined, permanent, persistent presence

Several things were critical to this theme: Building partner capacity, population control measures, and engineer support. As mentioned above, both Coalition and Iraqi forces were critical to setting the conditions for developing the police force. LTC Deane made an interesting comment that had the American forces been more robust, they may not have engaged with the Iraqis as intensely as they did.

Unfortunately, population control measures such as berming because of the size, density, and sprawl of the city were not practical.⁷⁷ However, Coalition forces used natural and man-made features, such as the Euphrates River, lakes, canals, and railroads, to their advantage as they planned and executed operational control over the city.⁷⁸ They then moved, generally, from west to east to push insurgents from the areas.

⁷⁶ Abd al-hakim Muhammad Rashid, Hadithah Mayor, interview with Dr. William Knarr, Colonel Dale Alford, USMC, and Lieutenant Colonel David Graves, USMC, his office in Hadithah, 14 Apr 2010.

⁷⁷ This was done in Fallujah during and at the conclusion of Operation AL FAJR and also in the Hadithah Triad.

⁷⁸ Typically analyzed as they developed their Modified Combined Obstacle Overlay.

Engineer support was integral to the strategy. Canalizing the enemy with barriers and building combat outposts allowed the Coalition and Iraqi forces to remain in an area and sustain large scale attempts to remove them.

5. Continuous storyline connected by relationships and events

The Awakening was much more than Sheikh Sattar's announcement on 14 September coining the term. Governor Mamoun Sami Rashid, Al Anbar Governor from 2005 to 2006 provided a sequence of actions throughout Al Anbar that culminated in the Awakening:

When we started fighting Al Qaeda in Fallujah [2004], the fight started to trickle down to Al Qaim [2005], then Hadithah [2006], then Anah, Rawah, and all these cities. The tribes with the help of the coalition forces, they took the fight to Al Qaeda. The last round of fighting was in Ramadi [2006/2007].⁷⁹

Additionally, these areas were connected through the "Sheikh network," that unofficial grapevine of social connectivity that Americans were not part of. Rather than the starting point, Sheikh Sattar's *Sahawa* was the product of accumulating events.

6. Reinforcing success

The deployment of two companies from 2/4 Marines into the Ramadi area was critical to TF 1-9's expansion in their sector. According to MacFarland, GEN Casey saw an opportunity to "reinforce success" and additional troops were what TF 1-9 needed to accomplish the mission both in Julaybah, the eastern-most Shark Fin, and then in the Mula'ab.

7. The Fog of War?

Intelligence reports and assessments were not keeping pace with the realities on the ground. Many people scratched their heads over the MEF intelligence assessment in August and ultimately questioned the credibility of the intelligence system. If counterinsurgency is a bottoms up war, where the intelligence comes from the population, then why wasn't the intelligence staff listening to the commanders on the ground and community who were engaging the local leaders? Unfortunately, leak of the report was particularly damaging as it diverted leadership attention from the job at hand to responding to a questioning public and congress on the status of Al Anbar, not to mention the information operations victory it handed to AQI.

8. Engagement and relationships

Many people speak of engaging the population and the importance of relationships. Charlton stated that "your relationship with the population is your force protection" and described it as different "doors" into the society and what those doors provide. According to

⁷⁹ Mamoun interview, 7 Apr 2010.

COL Charlton, the normal doors are the ones to security and government forces. Another door is to the elected or appointed officials. “We got those.” But there are three other doors that are critical, in a country like Iraq in particular—”tribal leadership, religious leadership and reconciliation.”⁸⁰ The Coalition’s problem for a long time was that it didn’t understand the importance of the tribal leader door.

Sheikh Sattar introduced Charlton to three key clerics in Al Anbar and taught “this dumb infantryman that Muslims aren’t bad people. And Imams are not bad people. They’re in fact greatly respected by the Iraqi population, and if you want to have acceptance by the population, you need to be accepted by these guys and have a relationship just like you do with the tribes.”

He went on to say that this also gives you a very powerful tool in combating terrorism. Al Qaeda’s main tool is ideology; when they move into a neighborhood, their first stop is the mosque, “it’s their ideological base. They will try to take whatever ideology is being preached to that mosque and replace it with their version.”

They will do it by coercing, replacing or just bypassing the Imam and will broadcast their own sermons on Friday over the loudspeaker. The mosque becomes their recruiting base because everybody goes there. They will get like-minded individuals who are vulnerable to support them from that mosque.

A first-hand account was provided by Dr. Thamir Ibrahim Tahir al-Assafi, Professor of Religious Studies, al-Anbar University, Senior Theologian to the Sunni Endowment (*waqf*), and member of the Council of Muslim Scholars:

Al-Qaeda took over these mosques, and they put in their Imams. They would bring Imams preprinted statements...to read. Al-Qaeda took over my mosque and put somebody from Al-Qaeda into it. I had several attempts on my life [as did]...a lot of the good, moderate Imams. Al Qaeda basically occupied all the mosques.⁸¹

“So how do we fight that?” According to Charlton, you can’t unless you have a relationship with the clerics, keep attuned to what’s happening and being preached at the mosques, and work with and through those same clerics to understand and reconcile issues.

Reconciliation was Charlton’s third door.

In general it was Sunni/Shia or Arab/Kurd. But in Al Anbar it was getting the Ba’athists to no longer support the insurgency. A lot of them only wanted to rejoin their role in society and collect their pensions, go home and live in peace.

According to Charlton, that was another door you had to walk through.

⁸⁰ Charlton interview, 20 Oct 2010.

⁸¹ Dr. Thamir, interview with Dr. William (Bill) Knarr, Colonel Dale Alford, USMC, and Lieutenant Colonel David Graves, USMC, Albu-Risha compound, Ramadi, 12 Apr 2010.

Appendix A. Coalition Perspectives

Notes on conventions used in the transcripts

- Ranks. The first time a service member is identified, their rank is spelled out; subsequently, their rank is abbreviated in accordance with their service affiliation. Ranks are spelled out in the footnotes.
- Time “hacks” on transcripts correspond to video so they can be used to identify areas to use as clips for the movie, the DVD and for further research into specific areas.
- For al- or Al- or Al in a proper name: When “al” is in the middle of the name, in a last name, for example, it should be lower case with a hyphen, such as Nuri al-Maliki. If the name is by itself then the “al” is capitalized, as in Al-Maliki.
- The majority of tribal names begin with the term *albu*, a formal characterization of *the*. When the tribal name is included in an individual’s name, the prefix “al-” is added and the tribal name changes slightly, usually with the addition of *awi* or *i* at the end. For example, Albu-Risha becomes al-Rishawi and al-Assafi denotes a member of the Assaf tribe or Albu-Assaf.

Table A-1 gives the reader an appreciation for the units responsible for AO Topeka from 2003 to 2008. Readers can refer to it to see what brigade-sized unit was assigned responsibility for the area.

Table A-1. Brigade/Regimental Units Responsible for AO Topeka, 2003–08

Deployment Dates	Unit Commander	Unit
May – September 2003	Colonel David Teeples	3 rd Armored Cavalry Regiment
September 2003 – August 2004	Colonel Buck Conner	1 st BCT/1 st Infantry Division
Aug 2004 – Aug 2005	Colonel Gary S. Patton	2 nd Brigade/2 nd Infantry Division
Aug 2005 – June 2006	Colonel John L. Gronski	2 nd BCT, 28 th Division
June 2006 – February 2007	Colonel Sean MacFarland	1 st BCT/1 st Armored Division
February 2007 – March 2008	Colonel John Charlton	1 st BCT/3 rd Infantry Division

Subject: Interview with Brigadier General Sean MacFarland, former Commander, 1st Brigade Combat Team, 1st Armored Division

Brigadier General Sean MacFarland, commanded the 1st Brigade Combat Team, 1st Armored Division (1st BCT/1AD) in Iraq from January 2006 to March 2007. The 1st BCT/1AD, also known as the Ready First Combat Team (RFCT) deployed to Iraq in January 2006 and replaced the 3rd Armored Cavalry Regiment (ACR), commanded by Colonel McMaster, in Tal Afar, north of Baghdad. Then in May the RFCT received orders to deploy to Ramadi to replace the 2nd BCT of the 28th Division, a National Guard unit from Pennsylvania.



BG MacFarland, former Commander, 1st BCT/1st AD

The RFCT RIP'd (relief-in-place) with the 2BCT/28th Div on 7 June 2006. Although scheduled to redeploy to Germany, their home station, in January 2007, they were extended and redeployed in February/March 2007.

BG MacFarland is currently the Deputy Commanding General for the Combined Arms Center, Fort Leavenworth, Kansas and he was interviewed on 13 October 2010 by Dr. Bill Knarr and Mr. Bart Woodward of IDA in his office at the Lewis and Clark Center.

Dr. William Knarr: General MacFarland, please start by providing background on pre-deployment? After that I'd like to follow the sequence of events during your deployment.

Brigadier General Sean MacFarland: Pre-deployment, well the brigade had recently returned from a 15-month deployment, so we had about 40–50 percent veterans from that deployment still within the brigade. We also had another percentage of new folks from other units who deployed before. It put us over the 50 percent mark in terms of Iraq veterans within the BCT.

We went through about a year-long redeployment, reintegration, pre-deployment train up. Our pre-deployment training was really focused in about a six-month period. There was some question about whether or not we would be, as they called it, off ramped—whether or not we would actually deploy and just go into a PTDO [Prepare to Deploy Order Status]. There was some confusion. So we went back and forth, back and forth.

Are we going to Kuwait? Are we going to Iraq? Which unit are we going to replace? Is it going to be the 3rd ACR? Are we going south of Baghdad? Are we going to go out west? Are we going to go up north? There was a lot of confusion in Europe as to where we would actually end up.

So, we tried to take a relatively balanced approach towards our pre-deployment training and essentially prepare for any of the above contingencies. That hurt us in some ways in that we didn't overly focus on one area of operations. In the long run, it probably helped us, because we ended up fighting in two distinctly different AOs [area of operations]. Ultimately, we saw the full spectrum of operations, so I'm glad we prepared for a full spectrum of operations before we deployed. Ramadi actually had some elements of intense urban, high-intensity combat as well as some of the stability operations that characterized the area that we were originally in, Tal Afar and west Ninawa province.

Knarr: You mentioned bringing lessons down from Tal Afar, such as COPs [combat outposts], etc. What were some of the lessons?

MacFarland: Well, when we first deployed we had to pick up some gear from the 3rd ACR south of Baghdad and move it up to the Tal Afar area. We took over Tal Afar, the Syrian Border, Rabiya and West Ninawa. When we got up there that was the area that had recently seen the operation by the 3rd CAV in Tal Afar, which pretty successfully knocked down the insurgency. However, the Iraqi Police had not returned from training in large numbers. The 3rd ACR was in their combat outposts, pretty much holding down the area until the police could begin coming in so they could move into more of the hold phase, instead of just the clear.

There were some hot spots still lingering in and around Tal Afar that we had to deal with. There was a long, long lag in the reconstruction money that was promised to Tal Afar, and it eventually began trickling in on our watch there. But we were fortunate in that we had a good Iraqi Army Division, the 3rd Division, and we had a brigade of border security guys out there along the Syrian Border. It looked to me like there were a significant number of areas that we could turn over to the Iraqis. The exception was the city of Tal Afar itself where we would have to maintain a presence for some period of time to work with the Iraqi Police as they began to filter back in. Like I said, there were still some hot spots that we had to deal with. [4:55]

So, we began looking ahead to the potential of us being moved out of that area into a new area of operations. We figured out which [areas] we wanted to turn over first to the

Iraqis, and we began that process even though it wasn't clear that we would be the unit that would move. It seemed to me that there was a high potential. We'd heard the rumors, so we wanted to at least be prepared for it. The original focus was getting the Iraqi Army and the Iraqi Police ready to accept responsibility in as many areas as possible, getting the reconstruction money flowing into those areas in particular, and knocking down the remaining hot spots. The activity level for the enemy in the Tal Afar area was not particularly high compared to what we eventually saw in Ramadi, but that was a pretty good dress rehearsal for what we eventually ended up doing in Ramadi. Ramadi was like Tal Afar on fast forward in a lot of respects. We had everything going on that we had going on in Tal Afar, but in a much more condensed timeframe. So, it was a good preparation for our eventual commitment in Al Anbar.

Knarr: You talked about developing the COPs and engaging the people. Did General McMaster move through the engagement process the same way you did when you moved into Ramadi?

MacFarland: Well, H. R. [McMaster] had a little bit of a different situation in Tal Afar, (well, so did I initially) in that you had a much more diverse ethnic mix. That's a mixed blessing, because you can pretty much count on the Shia being friendly to you in Tal Afar and the Sunnis being more hostile. So, you had 'go' and 'no go' areas or 'go' and 'slow go' areas in Tal Afar. You had your safe havens for us, and you had safe havens for the bad guys. You kind of knew where the demarcation line was. So when you flipped a tribe in Tal Afar, that was great, but there was always the problem of how do you get their opposite numbers on the other side of the sectarian divide to flip, also. [07:36]

In Ramadi, it was more of an "all or nothing." There were no partial solutions in Ramadi. They were all Sunni Arabs and a lot of former Ba'athists. Pretty much, once we found the key to unlocking Ramadi, that approach was going to work consistently. But if we couldn't find that key, we would have no safe areas to operate in Ramadi. That's the situation we found initially, the whole city was hostile.

The initial effort was, "Okay, how do we get a toehold?" At least we had a toehold in Tal Afar. We didn't have that initially in Ramadi. The other thing about Ramadi was it was a lot bigger than Tal Afar. I mean, I think it was four or five times the size. In large cities, the tribal affiliations break down. So, in Tal Afar, the tribes pretty much controlled what was happening in the city, because it's a small city. In Ramadi, that only applied to the very fringes of the city. The center of the city was in some respects like

Baghdad. The tribal affiliation is fairly weak and you have to find a different approach, which is what gave birth to the Sons of Iraq in Baghdad. You couldn't have done an Awakening to the center of that city. And we had a similar challenge within the center of Ramadi itself. We had to move beyond the pure tribal solution and find community leaders as well within the city. We had to find a strong mayor like we had in Tal Afar, who could work with other entities. So, there were some significant differences. [9:49]

Knarr: Could you talk about the importance of where Ramadi was situated in relation to the Western Euphrates as it led down to Baghdad? Why its location is so important. Not just simply because it was the provincial capital, but because of where it was located.

MacFarland: Well, a third of all the population of Al Anbar lived in and around Ramadi, so it was a fairly densely populated area to begin with. The other thing about Ramadi is it sat on a chokepoint between the reservoirs and the lakes, the great lakes that separate Baghdad from Anbar Province. The Euphrates River, major highways, and railroads run through that chokepoint in Ramadi, and from there they split off to Jordan and Syria. So if you are a foreign terrorist from Yemen, Syria, Egypt, or wherever and you want to get to Baghdad, you're going to probably pass through Ramadi. When the Marines and the Army cleared Fallujah, a lot of those folks moved out to Ramadi. Ramadi became their base of operations where they could sortie into Baghdad or against Fallujah or down into the area south of Baghdad up to Diyala Province north of Baghdad. So, they could influence the belts or they could get into Baghdad proper. Ramadi is an important location and Al Qaeda recognized this. They chose it as the capital of their Caliphate that they wanted to re-establish. It had some sort of a symbolic significance for Al Qaeda, because they had in essence planted their flag there after Fallujah. They said, "Okay, this is going to be our capital." And then it had geographic significance as I mentioned. So, those factors combined to make Ramadi a pretty hard fought battle. Then, of course, the urban and dense population complicated matters.

The other thing is just to the east of Ramadi is the boundary between the Dulaymi and the non-Dulaymi tribes. Although they were still predominately Sunnis to the east of Ramadi and in Fallujah, it was a different tribal coalition. So, the tribal dynamics, the human terrain, was interesting as well, because we had that boundary right along my boundary with the 5th Regimental Combat Team.

Knarr: You arrived in Ramadi around the first part of June. In reading the article, you had a strategy when you walked in.¹ What was that strategy?

MacFarland: Well I had a plan, let me put it that way, which ultimately led to another plan, which led to another plan. No plan survives contact with the enemy. Our plan initially was to make Ramadi look like Tal Afar. It was about as simple as that. Of course the devil is in the details, and we had a number of ways that we wanted to accomplish that. Having just come from Tal Afar and seeing the aftermath of 3rd ACR's kinetic operations, I knew that I had to go through those kinetic operations in Ramadi to get to where we were in Tal Afar. The challenge is that I didn't have the force ratio that 3rd ACR enjoyed in their fight. I couldn't take the whole city and put a big squeeze on it like we had in Tal Afar. What they did up there was isolate it, and then they moved in concentrically toward the center of the city. That would have taken three times the number of forces that I actually had. So we tried to isolate the city as best as we could. Then instead of doing a massive push from two directions, we did more of a piecemeal approach where we took one neighborhood at a time. It evolved into where we were able to work from west to east through the city essentially with a Marine battalion to the north of the main east/west road in Ramadi, Route Michigan, an Army battalion to the south, and an Army battalion to the east forming the kind of anvil that the two hammers were pushing up against. That was kind of the approach that evolved.

Now, because I said I didn't have enough forces to work my way through there, I knew that I had to invest heavily into the development in Iraqi Security Forces. We had a veteran Iraqi Army Brigade to the east, the 1st Brigade of the 1st Division, as part of the anvil. [16:04, 1st video clip ends, 2nd clip begins] I also had a brand new Iraqi Army Brigade, the 1st Brigade of the 7th Division to the west. They weren't going to be much of a contribution to the hammers until they were developed a bit more. And I had virtually no Iraqi Policemen, so I knew I had to go out and get Iraqi Police.

North of the Euphrates River and to the west of the Habbaniyah Canal, I had other operations going. I had two more Army battalions. One Army battalion was in the north in the Jazeera area, and they were also going basically from west to east. They were more in a tribal engagement mode, trying to win them over, although there was a fair amount of fighting to the north of the river.

¹ Major Niel Smith, US Army, and Colonel Sean MacFarland, US Army, "Anbar Awakens: The Tipping Point," *Military Review*, March–April 2008.

And then to the west, the Habbaniyah Canal was part of the city of Ramadi called Ta'ameen. [There was also] the Five Kilo area and points west and south. That was my economy of force effort, and as it developed, that's where Sheikh Sattar lived and where our tribal engagement began to first take root. Also, directly to the north of Sheikh Sattar is the Albu-Risha tribe. It was also pretty successful tribal engagement. So, west to east was basically our approach.

The isolation efforts that initially took place, though, were we had to take Ramadi hospital. It was the most dominant terrain feature in the city at seven-plus stories high. You know, it dominated the city and it was being used not only as a medical facility for the insurgents, but also as an observation post. And then to the south of the city, we had the train station area. I had to take those two areas back, and that's where we began our operations to really isolate Ramadi at the beginning. Then, as I said, we had to get multiple lines of operations. The Marines in the north had access to the north part of the city, and in the south part of the city we were isolated by this canal. There was a railroad bridge down there. We had to secure that whole dilapidated railroad bridge, and then establish a bridge head essentially on the other side, which we did. So, that's how it all kind of began. [02:48]

Knarr: Now we are in June. In fact, we saw Tony yesterday...

MacFarland: Tony Deane?

Knarr: Yes. What a story! He's got a story that is integral to the Awakening.

MacFarland: Well, I would agree. What Tony did was what all of our battalion commanders were doing throughout Iraq, which was going around and figuring out who we could work with and who we couldn't. We knew that we had to work with the tribes to get Iraqi Police recruits, and Tony found a surprisingly willing partner in Sheikh Sattar. Sheikh Sattar had a lot to lose. He'd already lost a lot, and he could have very easily—although he had an intense hatred for Al Qaeda and a deep mistrust of the Persians, as he called them. He could have easily been written off as a minor player and marginalized, but Tony saw the potential of this partnership. And Sattar, to his great credit, also saw the potential. So, those two were really the initial team, a dynamic duo. Tony recognized that Sattar had much more potential than a local partner for 1st Battalion, 35th Armored Regiment. He really had brigade and beyond level potential, so Tony came to me and said, "Hey, sir. You really need to meet this guy." He handed him over to me to become my principal partner. [5:07] That's graduate level stuff, and Tony managed it just right. It could have gone wrong. In fact, Sattar had reached out before, and he had been pushed away or had pulled back for

reasons of his own and remained sitting on the sidelines. The communications with him were incredibly important, both verbal and non-verbal communications. We had to show Sattar that we were the allies. We had to put our money where our mouth was. Tony was a key player in that. There are a couple guys who were key players, and I think Jim Michaels' book does a pretty good job. I don't know if you...

Knarr: I've read it.

MacFarland: When he talks about Jim Lechner and Teddy Gates...

Knarr: Yes! I recall, among other things, Lechner's naming of the substations.

MacFarland: All that! When Tony turned Sattar over to the brigade to manage the engagement, Jim Lechner and Teddy were brought into the equation. Those two guys also did a masterful job of delivering everything that Sattar was asking for or at least everything that I promised Sattar. I mean, Sattar asked for a lot that we didn't give him, but what I said I would give him, we did, and that was thanks to Jim and Teddy. Teddy is a Marine Major, and Jim is an Army Lieutenant Colonel. Additionally, at the Brigade level, Travis Patriquin, my S9, began cultivating Sattar, Sattar's family, and his circle of friends. Jim mostly dealt with Colonel Tariq, who eventually became a Major General, but he also dealt a lot with Sattar as well.

But it was really bringing all guns to bear on this opportunity and really bringing that relationship to its full potential. Now that's not what I went down there planning to do. I mean, you said what was your plan, you had a plan. I had a plan to work with the tribes, of course, and I wanted to find friendly tribes. I was hoping to get folks from the tribes to join the Iraqi Police and then allow me to move forward, because I was going to run out of combat power as I cleared the city. I didn't know how far into the city I'd be able to push unless I could bring police in behind me to secure, and that was what I was going to keep on doing. I thought we had a couple of years before we would get to a respectable number of policemen in the city. I didn't expect it to happen that rapidly. Sattar is the one who made it happen much faster than we anticipated, and then we had to adapt. So, yeah, I had a plan, but we had to adapt our plan pretty quickly to reality. Fortunately, it was adapting in a good way, not in a bad way. We were able to exploit success. [9:06]

Knarr: Can you describe some of the first meetings you had with Sattar? I guess you had one on 9 September and then another one on the 14th.

MacFarland: Right, and Tony had been talking to me about Sattar, and I had said, “Hey that’s great! Keep developing him. He sounds like an interesting guy. I think we’ll be able to get some support from him” But, it was a fairly small tribe, so I wasn’t expecting large numbers from the Albu-Risha tribe, and in fact, we never really got a huge number of guys from that tribe. Percentage-wise, we got a high percentage from that tribe, but it just wasn’t a big tribe. So, Tony said, “Yeah, you got to talk to this guy.” I said, “Alright, I’ll talk to him. I’ll meet with him,” but I hadn’t planned to meet with him the first week of September. It was something that was kind of out there as something I was going to do one of these days. I was dealing with meeting a lot of other people at the same time, and we were still just in the opening phases of our own operations.

At first, I was spending a lot of time with the governor. About the time I had come to the conclusion that really the governor wasn’t going to be a big help to me, was about the time Tony said, “Hey, Sattar has the potential of being a really good partner for you.” That was very serendipitous, because obviously the government wasn’t going to really help us. So, we were looking in a non-governmental area for local support. So, I was very eager to meet with Sattar when he told me that he’s got a bunch of other sheikhs who want to talk. Now Sattar initially was the spokesman. He wasn’t the leader per se of the Awakening, but he was willing to put his face out there without a ski mask on and brandish a weapon and say, “I’m not afraid of you Al Qaeda terrorists. Come and get me if you can, but we’re going to fight you!” Holy cow, there aren’t very many guys like that at all. My experience in Tal Afar was that there was nobody up there that was like that with the exception of the mayor, who was not from the city of Tal Afar. So, here you have a local guy who is willing to step forward and do this. That was unprecedented in my experience, so I was very happy to go meet with him.

I wasn’t able to meet with him on the day that the Sheikh requested. I forget why. There was some major thing going on, but within a few days, I was able to get down and talk with him. I think I’ve said this before, but when I walked into the room it was like a scene out of Lawrence of Arabia. All the tribes were represented by their sheikhs in their finest robes, and there at the front was an empty seat for me to go and sit down next to Sheikh Sattar. So, obviously they were expecting me. They plunked me right down in the middle of this and began to rattle off their manifesto, their 11 planks of their platform for the Awakening movement. They were all good, and as I’ve said before, had somebody asked me to write something like that, it would have been very close to what they came up with. There was some dispute over how it is exactly they wanted to address

their grievances with the governor of Al Anbar, Governor Mamoun. I thought that they were a little threatening in their language. We toned that down and made it a little more constitutional sounding, which they readily acceded to. They said, “Okay, that’s fine.”

The key part of that, though, is where they said that an attack on the Coalition Forces will be viewed as an attack upon members of our tribes. That sounds like a throwaway line in western society, but it is deeply meaningful in tribal society and tribal culture, and they really mean that. When I lost soldiers in one of those tribal areas that had signed on to the Awakening, then, true to their word, the perpetrators were very rapidly either killed or captured and delivered to us, because they had been insulted by that attack. Their tribal honor had been impugned. So, it was really a significant development, and I probably didn’t recognize at the time how important that language really was. It became evident pretty quickly to me that that was probably the key sentence in that whole document. Within days of a tribe signing on, attacks in those areas on friendly forces would drop to zero and the caches would pop out of the ground like mushrooms and be turned in. We got reflections through our intelligence sources, and Al Qaeda would have to flee the area almost immediately. So that was tremendously important.

And then those sheikhs once they flipped, they’d be at my door saying, “Okay, deliver on your part of the bargain.” This is where Jim and Teddy came in, and the local battalion commanders would establish local security stations, arm the auxiliary police that were drawn from tribes, vet them, train them, and provide them with oversight and quick reaction forces. [15:56] It only took a couple of instances where one of these neighborhood watch-type of stations were attacked by Al Qaeda, and we would swoop in with Marine F-18s or Navy F-18s and dispatch the attackers with a strike from above that they began to recognize the great power that their partnership brought to them. And of course, we gave them all the force protection: the barrier materials, the concertina, the weapons, communications, and so forth. We gave them the ability to withstand attacks.

Well, once their tribesmen were protecting their own tribe members and once they had the wherewithal to do it, that was tremendously empowering. The key, in my opinion, to any awakening movement is that the indigenous people, the indigenous forces, are empowered to protect themselves. They are no longer reliant on anybody. They’re not relying on the Iraqi Army, which is a federal institution. They are not relying on Coalition Forces so much. To some extent they are, but largely their security comes from themselves—people that they know and trust. That’s something that we in the United States can certainly relate to. I mean, that was the whole idea behind the Minute Men and on

down through the centuries in the United States from days of the first pilgrims. We had our own little militias. We didn't rely on England to send over Red Coats to protect our initial colonies. We had our own militias. It's the same.

So that was really the key. That's where Jim and Teddy and those guys really empowered these forces, and that was a bit of a change from the original model. In the original model, the Ministry of the Interior picked the locations for the police stations that were going to go into Ramadi. It was a very federal centralized kind of approach. You would have X number of policemen, they will be armed this way, and that's the way it's going to work. [18:30]

We couldn't get approval to build new police stations, so we called them substations. We asked the sheikhs, "Where do you want these stations?" They would tell us, and we would put them where they wanted. It wouldn't necessarily be where we would think would be the right place to put them, but fine. We would allow them to man these police stations first and only once they felt secure in their own neighborhoods, would we ask them for recruits to go serve in other parts of the Ramadi area of operations. What that did is it broke the cycle of murder and intimidation, which had kept all their willing tribesmen away from working.

In fact, the first police substation that we set up was manned mostly by former police who had already been trained. They just quit, because they didn't feel safe or they didn't feel that their families were safe if they were working as policemen, so they came back to the colors. We got a big initial surge of those guys which helped us until we began to get trained policemen back in. Then the supply was too great for our pipeline and that's when we began forming these auxiliary policemen. We gave them a modicum of training either through my Artillery Battalion, the 2nd Battalion, 3rd FA [Field Artillery], under Colonel Joe Harrington or our SEALs [Sea Air land] under Task Unit Bruiser SEAL Team 3 initially, and then SEAL Team 5. [20:12]

Knarr: So your paddle [I am looking at a paddle "memorabilia" with the unit name presented to him by the SEAL Team that supported RFCT in Ramadi].

MacFarland: Yeah! Those guys are great! [00:00 video tape 3] We call them the Army SEALs in Ramadi, and they called themselves Army SEALs. They were fantastic partners, fantastic, especially when it came to setting up the combat outposts. In fact, that picture that you mentioned was a Quick Reaction Force going out in response to a SEAL team that was under attack.

Knarr: You said “first substation.” Which one was that?

MacFarland: I think we called it the Al Jazeera substation. It was an old pump house right across the bridge, right across the Euphrates River. That was the one that was the focus of the attack, which really spurred the Awakening. Our initial support for these police recruiting drives did not come from Sheikh Sattar. It came from the Albu-Ali Jassim tribe and the Albu-Thiyab [Aka Diab] tribe, which was north of the river in the Jazeera area and in the northwest part of my AO. Sheikh Khalid [Sheikh Khalid al Irak al-Jassim] of the Albu-Ali Jassim’s was the elder sheikh in the area. The Albu-Thiyab Sheikh’s name was Shiekh Heiss [Sheikh Hamid Farhan al-Heiss]. Those two guys were our first big supporters, and they had fairly large tribes. They were the ones who told us where to put this police station. So we kitted it out and put an MP [military police] squad in there.

I think it was late August when Al Qaeda recognized that this police station posed a threat and that the sheikhs who were beginning to support us were also a threat. We moved our recruiting to a location closer to the tribal area where the recruits were coming from. They said, “We don’t feel safe going into Ramadi to be recruited.” There had been a suicide bomber who had killed a number of police recruits at the old glass factory in Ramadi, and that’s where our predecessors were doing all their recruiting. So, we said, “You know, why don’t we just do it up at Camp Blue Diamond,” which is closer to them. They said, “Okay, that’s great!” So we got a lot more recruits, and then we put the police station where they wanted to put it. Sheikh Heiss of the Albu-Thiyab tribe and Sheikh Khalid were pointing to this and saying, “Hey this is a good deal. This is what we want to do.”

Then Al Qaeda murdered Sheikh Khalid as he was leaving another Sheikh’s home along with one of his sons, I believe as well, and a nephew. In the same day, they also attacked this police station. The police station attack was partly successful. It was a big fuel-enhanced vehicle-borne IED. It was a truck. Although it didn’t kill very many people, it burned a lot to include the better part of the MP squad that I had in there, US Army MPs and their platoon leader, now Captain Scott Lefger [ph].

I was out and about, and I saw this mushroom cloud go up by that police station. I got over there pretty quickly. It was still in flames at the time, and I found the Lieutenant Colonel Iraqi Police Commander. I said, “Hey, listen, you don’t have to stay here. We’ll secure the area, and we’ll bring you to Camp Blue Diamond just a couple kilometers away until we can get this back in operation.” He said, “No. I’m not going to do that. That would be a defeat. We don’t want to let Al Qaeda see us run away.” So, they put

their tattered, burned flag back up, and they actually began doing patrols. I call it the Iwo Jima moment. They let me take their badly burned and wounded policemen out, but the rest of the policemen stayed there. We just reinforced them on the site. That day, they actually caught some of the people that were associated with the Al Qaeda cell that made the attack. [5:22]

That was one miscalculation by Al Qaeda. In the past, when they went up to a police station and said, "Leave your weapons, go home, and we'll let you live," those police had no stake in where that police station was. They would just leave. Well, this police station was in the middle of these people's homes. Where were they going to go? Would they go back to their homes to await the knock on the door from Al Qaeda? No! They'd rather keep their first line of defense.

When I left that police station, I was driving along, and I saw Sheikh Heiss. He was with his, I think it was his, nephew who had been badly burned in the attack. I took Sheikh Heiss and his nephew in my HMMWV. We gave him first aid, and we took him back to Camp Ramadi and put him in Charlie Med. And so that was another miscalculation of Al Qaeda. I think that was the first time I'd met Sheikh Heiss was when I stopped and gave first aid treatment to one of his close relatives, put him in my HMMWV, and drove him to Camp Ramadi. That was the Albu-Diab tribe. Then the third miscalculation was with the Albu-Ali Jassim. Al Qaeda killed Sheikh Khalid, and they left his body in a place where it couldn't be found for several days. All of the Iraqi police that I had recruited to that point disappeared for a few days, so they could go out and look for Sheikh Khalid's body, which they eventually found. But that was a clear violation of cultural norms, and it became obvious to the average Iraqi citizen that the Americans were much more respectful of the Islamic culture than Al Qaeda was in many cases. So, that insult was what really caused a lot of the sheikhs to ban together and realize that if we don't hang together, we will hang separately, to use an old expression.

So, they came together at Sheikh Sattar's compound. Sattar was the spokesman, and the older sheikhs were quite willing to let this young hot-head sheikh take all the risk and be the face of the movement. The other sheikhs were thinking that Sattar could run the risk, and they could reap the benefits. Sheikh Sattar eventually parlayed that into leadership of the movement. We were a willing partner in that. When Sheikh Sattar became the most forceful spokesman for the group and the most forthcoming, naturally we gravitated towards him and Sheikh Heiss from the Albu-Diab. Everybody was looking to Sattar to take the risk. We tended to provide the most support to Sattar and the Albu-Risha,

which built them up from a second- or third-tier tribe to a much more influential tribe or at least him to a more influential sheikh. He, in essence, became sheikh of sheikhs, mostly because he was viewed as the conduit to the American largesse.

That didn't bother me at all, because the tribal situation was a bit murky to me. We were working on it, but I knew I'd never get total clarity on the situation. Only the sheikhs really understood that situation. If I was going to succeed, I had to have sheikhs that I could trust, so I picked a couple and backed them heavily. If they were not the natural leaders, I artificially elevated them to leadership positions. Maybe I violated the hierarchy in some ways, but it worked. They became de facto elder sheikhs through that. So, we basically created, in some ways, Sattar's power base.

That was one of the discussions that I was having with my higher headquarters. Who should we really be setting up for the leadership role among the sheikhs? A lot of the elder sheiks were in Jordan. Was it them or was it the local sheikhs that were here and left behind in the second and third-tier guys? So the tension was, do we adhere to the existing hierarchy or we do create our own hierarchy? Those of us who were more at the tactical level were saying, well these are the guys we know, let's back them. At the operational level they were saying, well we're working this thing with the guys in Jordan, let's back them. Ultimately, both approaches bore fruit. The Awakening consisted of Dulaymi tribes and could only go so far. It couldn't really affect Fallujah, and that's where you needed the sheikhs who were in Jordan to really propagate the movement into the Fallujah area towards the Baghdad belts. So, there was no right or wrong in that discussion. I think everybody was right. [11:27]

Knarr: That's a good point. I never see that point.

MacFarland: And the MEF [Marine Expeditionary Force] essentially gave me free rein to do what I was doing. Although they had their doubts and were skeptical, they said, "Okay, you're on the ground. Go ahead." A guy I give a lot of credit to for the MEF's more expansive approach, is now Lieutenant General John Allen. He actually came in with II MEF. In Tom Ricks's book I called him "Mozart to my Salieri" because what I was able to do locally, he was able to do province-wide.

Now my approach wasn't unprecedented, because Dale Alford had done something similar with the Albu-Mahal tribe in Al Qaim. But they were one tribe that straddled the border. They basically did it for their own purposes, which was to get the smuggling business back to where it once was. This was not unlike their friends up in Rabiya who

I had dealt with. Sheikh Abdullah and the Al Shammari tribe controlled the port of entry up at Rabiya. Sheikh Abdullah was prospering quite nicely. Rabiya was a very quiet area even when things were very contentious in and around Tal Afar and even Sinjar. In Rabiya you know, commerce kept flowing. Now, it was very corrupt commerce, but the Shammaris controlled both sides of the port of entry, so it was in their best interest to make sure that things kept flowing. I'm sure the Sheikh of the Albu-Mahals looked at his friend Sheikh Abdullah up there in Rabiya and said, "Well you've got a port of entry, and I've got a port of entry. We're in the same situation. I need to work with the Coalition." Now the difference was Al Qaim was far more heavily contested and the Marines had to fight a lot harder. There was an Army battalion out there working with them, but they had to fight a lot harder to get control of that area. They used some of the combat outpost approach that 3rd ACR had used up in Tal Afar. So, in some ways, Al Qaim was a microcosm of Ramadi. [14:24]

Knarr: Did you know about Al Qaim when you went down to Ramadi?

MacFarland: Not really, but one of the guys who did was the commander of 1/6 Marines who came in and replaced 3/8 for me.

Knarr: Bill Journey. I've talked to Bill Journey.²

MacFarland: Well, Bill is friends with Dale Alford.

Knarr: Very close friends.

MacFarland: Right, so when Bill came in, he had talked to Dale and said, "Well I can do some of this too." So, we were already kind of underway doing what had been done in Al Qaim and Tal Afar in Ramadi. So when I explained to Bill this is what we're doing, he said, "Well, that was basically already my plan." So, he was completely inside my head intent-wise. He actually took it to another level at the battalion level and instituted some really neat things there that we then used elsewhere within the brigade footprint. A lot of guys like Tony Dean, Bill Journey, V.J. Tedesco, Ron Clark from 1st of the 506 [1-506th], Chuck Ferry from 1st of the 9th Infantry [1-9th Inf], and John Tien from 2nd of the 37th Armor [2-37th Armor], came up with their own unique, really good ideas. At the brigade level, we'd come together and share those ideas. Then we would just spread that jam across the whole

² Colonel Bill Journey, interview with Dr. William (Bill) Knarr, 3 March 2010, his office at Joint Forces Command, Norfolk, Virginia.

piece of bread. So, a lot of these things that we did in the brigade really started at the company or even platoon level and percolated at the battalion and then came up to the brigade.

Knarr: I haven't heard anyone express it like that before. That's good. Well let me ask you something. In Al Qaim you've the Albu-Mahal. Additionally, elements of the Albu-Mahal located in an area of the Shark Fin [the Shark Fin area is East of Ramadi and is called that because the contour of the Euphrates River around the land resembles a shark fin when observed on a map or from overhead imagery] in Sofia adjacent to the Albu-Souda tribe. Sheikh Jassim of the Albu-Souda tribe, his brother-in-law was Sheikh Abdul Rahman al-Janabi of the Albu-Mahal tribe. In fact, Kurdi up in Qaim helped me find the MOD [Minister of Defense] back from 2005 who was a member of the Albu-Risha tribe. So I'm just curious, there seems to be this underlying network where these sheikhs really talk to each other and pass on information; I call it the Sheikh's net.

MacFarland: They do.

Knarr: Like Kurdi was telling me that Sabah of Albu-Mahal talked to Sattar of Albu-Risha in Jordan.

MacFarland: Yeah, and Sattar was going back and forth to Jordan and Syria all the time, because he's a smuggler. In fact, I think somebody reported on the border incident. I think Jim Michaels might have talked about it in his book. Sattar crossed ways with the Marines out there at Al Qaim. But, Sattar was telling me fairly early on in September/October that he was talking to Shia tribes, Shia sheikhs in Diyala and south of Baghdad. And I said, "Really, Shia?" He said, "Oh yeah, you know, a sheikh is a sheikh. We all get along fine." So, this tribal network was far reaching, and when he started telling me that, that's when I really got excited. I said, "This has national implications." That's when I started going to General Zilmer, General Reist, and General Neller and saying, "Wow, this network has its tentacles throughout the country, and Sattar could be a national player potentially, certainly provincial level!" So that was absolutely correct and there were, I forget which tribe it was out in Sofia, in the Shark Fin area.

Knarr: Albu-Souda tribe?

MacFarland: Well, no, no, no, but there was another tribe. The Albu-Fahads were split north and south of the river. The north of the river guys were friendly, and the south of the river guys, not so much. But they both owned big construction companies, and that was ultimately one of the ways that we brought the Fahads around is when we had the Ramadi Reconstruction Conference. But, there were whole tribes and pockets of tribes spread all

over the place. That's why I said, "I don't know how many tribes were in Ramadi." It depends on how you count. Were the Fahads north of the river different from the Fahads south of the river? I don't know, but the sheikhs knew! And that's what mattered. So, I used Sattar and Heiss and guys like that as my interlocutors with the tribes. I didn't try to get down into inside baseball with the tribes, because I knew I would just muck it up. [19:32] Some people, you know, dove a lot deeper into it than I did. At the tactical level you have to. You know the Tony Deane's and the Chuck Ferry's and guys like that. They really did know everybody in that tribe. Bill did a great job. What was the name of the tribe in West Ramadi now?

Knarr: Alwani?

MacFarland: Yeah, the Albu-Alwani.

Knarr: Yeah, with Mamoun.

MacFarland: And that's actually the governor's tribe, but they weren't really fond of the governor that much. His family was but that was about it. But, the Alwanis actually had a big footprint in the west part of the city. We started clearing from west to east, because when the Alwanis came into the Awakening, Sattar said to me, "This is the beginning of the end for Al Qaeda. It's all over now. Now that the Alwanis are with us, they can't stop us, because now we have a secure part of the city to operate in." That was huge! And then when the Soudas flipped on the east side, the enemy's lines of communication into the city were shut off. This is why they [AQI] were so adamant on fighting the Albu-Soudas and keeping that Shark Fin area open to their operations. So, when the Soudas and the Alwanis flipped, it was all just a matter of time at that point. The trap had closed, and eventually what was left of Al Qaeda resistance in the city would just have to peter out, which it eventually did.

Knarr: That is something.

MacFarland: But it wasn't the original concept of building a berm around the city like they did in Tal Afar and manning it with American and Iraqi soldiers to isolate it. We isolated through tribal alliances.

Mr. Bart Woodward: Why did they agree to work with the Coalition? [00:00 video 4] I understand they came on board in succession, but originally, what was their motivation to support you?

MacFarland: Well, they were being terrorized, and they weren't profiting at all. I mean, they were starving essentially. They had been reduced to an impoverished lifestyle. They were living in fear for their lives. Their prestige as sheikhs was being trampled upon. The tribes were being disrespected or disregarded. There were all kinds of motivations for them to come over.

People say, "Why did the Awakening happen? What was the most important thing?" People say, "Well, was it Al Qaeda's overplaying their hand, and forcing marriages upon unwilling partners? Was it Coalition combat outpost, and their presence in the tribal areas? Was it the tribe's willingness to fight?" And the answer is all of the above. I liken it to internal combustion or an internal combustion engine when people ask me that question. You never hear people ask, "Well what's the most important thing to an internal combustion? Is it the fuel, is it the spark, or is it the oxygen?" Well, it's all three; you can't have internal combustion without all three. Well, the same is true of an Awakening movement. The spark is provided by the enemy. They're the catalyst for an Awakening movement. I mean you won't have an awakening if you don't have a problem, right? Then there's the fuel. Well, the fuel is the tribes or the local population. The Awakening movement will only go as long or as far as the fuel supply lasts. And then the Coalition Forces are the oxygen. We provide the atmosphere through the breathing space for this to occur. We give them the space. We push in with our combat power and give them the capability to operate. So, you've got to have all three. If you didn't need the Coalition, you'd have awakening movements everywhere spontaneously occurring without Coalition presence, but you don't see that do you? And you only see it when there is a Coalition presence.

Woodward: Or you see a failure of it to happen [without one of the elements].

MacFarland: Which is exactly what happened in Ramadi before we got there in February of '06. Essentially the tribes tried to stand up against Al Qaeda and got smacked down hard, which put them on the side lines, because the Coalition didn't come to their assistance.

Knarr: Do you think it was ignorance on the part of the Coalition?

MacFarland: In large part. But it was ignorance on the part of the Iraqis, too, because they didn't step forward and say "Hey, we want to cooperate with you against Al Qaeda." They tried to fight two different directions at once. "We will maintain the honorable resistance against the Coalition while we fight Al Qaeda." So, they learned the hard way

that two against one are tough odds. So, they reversed that ratio when they teamed up with the Coalition and were on the big side of that ratio instead of the small side.

Knarr: Was that Muhammad Mahmoud Latif [MML]?

MacFarland: Yes, exactly. And in fact, Sattar said, “Hey do you want to meet Latif, because now he’s ready to be on our team?” I said, “No. You talk to Latif for me; I’m not ready to talk to Latif.” I said, “If I talk to Latif, I’m going to flex cuff him, because he’s got American blood on his hands, and I know that.” And I said, “You bring me guys that you know will pass my vetting process.” Initially, I was being accused by some of creating an anti-government tribal militia, so I had to tread carefully here. I could not bring in people to these auxiliary police forces that were known insurgents. Now, undoubtedly some of them were insurgents, but we didn’t know. We didn’t have evidence against them, so that was okay. I was willing to take those guys. But, if I knew and had evidence against them, I couldn’t bring them on board. That would have undermined my strategic communications effort with my higher headquarters, which was these guys are all playing on our team. Nobody’s got their own agenda to ultimately overthrow the Baghdad government or fight a civil war against the Shia. I had to make sure that these guys were all relatively clean. Latif was a HVI [high value individual]. There’s no way that I could say, “Yeah, and he’s on my team, too.” So, I said, “Listen, if he’s willing to lay down his arms or to operate in conjunction with you against the enemy, who am I to say no to that? But I’m not willing to arm and equip somebody who has a track record of fighting against my soldiers.” [6:07]

Knarr: When you talked about defining the Awakening, you said it was empowering the people to protect themselves. How did Sattar define the Awakening?

MacFarland: He defined it as them awakening to the fact that the Coalition was their friend and that the true enemy were the takfiri extremists. That’s how he defined the Awakening. I don’t know if it was Rick’s or Michael’s book where they have a quote from Sattar as to when he recognized that, you know, who his real friends were, that was the beginning of the Awakening. And I use to tease Sattar a little bit, because the Awakening flag that he designed, the crossed sabers, but it had a little coffee pot on top, you know the very strong coffee that they drank, and I used to say, “Is this a caffeine driven awakening? Is that what that coffee pot is all about?” But, that’s how he really saw it.

Knarr: In fact, Andrew Lubin had it in his article, “Ramadi from the Caliphate to Capitalism.”

MacFarland: Yeah.

Knarr: I talked to him on the phone the other day.

Operation SQUEEZE PLAY, you know I've never seen much written on it, but every once in a while I see it pop up. Was that yours?

MacFarland: Yeah. SQUEEZE PLAY was going to happen in about the December timeframe in Ramadi. I talked about the hammer and anvil, and we kind of squeezed the enemy into the eastern part of the city. So, I had 1st of the 9th, which was a fantastic unit with a fantastic leader, Chuck Ferry in the Manchus. I was going to take 1/6 Marines and 1-37 Armor, the Bandits, and seal the deal. The area that was still in contention was called the Mula'ab District of Ramadi. It was the area basically to the east of the hospital and the old Saddam Mosque, which is now called the Awakening Mosque by the way.

Knarr: We visited that. I didn't know that though.

MacFarland: Yeah, I've been RPG'd [rocket-propelled grenade] from the windows of that mosque. I had the front half of my HMMWV blown off passing by there one day. It was not a great place. Anyway, so that was the plan. We were getting two Rifle Companies of Marines of the 15th MEU, 2/4 Marines were coming ashore. General Casey had come a month or so earlier and said, "Hey, you guys are really starting to make some progress in Ramadi. I didn't really expect that." He said, "If I gave you another battalion, do you think you could secure the city?" I said, "Sir, I really don't need another battalion. I already have eight battalions, plus two Iraqi Army brigades that work for me. My span of control is pretty much at its outer limits" I said, "But I could use a couple more companies for the battalions that I have." So, he said, "Okay," and they brought the 15th MEU ashore. I got two rifle companies, Echo and Fox Companies from 2/4, great units, great commanders.

Knarr: I read Tom Daly's book, *Rage Company*.

MacFarland: I'm not familiar with that. I should read that.

Knarr: In fact, that's where I picked up SQUEEZE PLAY. I thought, Wow! [10:22]

MacFarland: Okay, well I've got to read this book, excellent. So, that was the plan. Then I went home for Thanksgiving on block leave. Everybody else had gone home, and we'd been extended. We were coming up on the one year point, and so I went home. On my way back, I think I was in Kuwait at the time, I get a phone call from my Brigade XO. He said, "Hey, sir, SQUEEZE PLAY is supposed to kick off, but we've got this fight going on up here in the Shark Fin. The Albu-Soudas are asking for help. We're thinking we ought to turn and support them and postpone SQUEEZE PLAY." I said, "Absolutely. You

don't want to pass up that kind of an opportunity," because we'd been courting Sheikh Jassim for a while. So, Chuck Ferry and the Manchus went up there, and the guys at Shark Base, the Special Ops guys supported us as well. They fought a pretty sharp fight up there, which really threw Al Qaeda out of that area, which we had been working at for quite a while. It was a pretty confused, swirling fight, but we basically did a 180 and secured that. So, that postponed Operation SQUEEZE PLAY for a while. I said, "That's okay." I mean Ramadi is not going anywhere. We've got our foot on the jugular of the Al Qaeda guys remaining in the Mula'ab District. It's only going to get easier for us to go in and secure East Ramadi over time. Time is now on our side. So, we went for Sufia (the Shark Fin). SQUEEZE PLAY eventually kicked off. It was our plan, but we didn't execute it. The 1st Brigade, 3rd Infantry Division actually executed SQUEEZE PLAY.

Knarr: I'm speaking with Colonel Charlton next week.

MacFarland: And they executed with two out of the three units that we would have executed it with. I think 3-69 Armor substituted for 1-37 Armor, but 1/6 Marines and 1-9 Infantry were the main players. They came in mid-way through my tour. So, you had experienced guys on the ground, and, like I said, the lifeline had already been kind of choked off when we secured the Shark Fin, so it was a good fight. John did a superb job of not only going in there and finishing it off, but then doing the hold and build part. I mean, just a fabulous job. John deserves every bit of credit in the world for that. The other thing that happened was the Marines put a unit up in the Lake Habbaniyah area to the north. We kept getting these suicide VBIEDs [vehicle-borne IEDs] coming down from Lake Habbaniyah. My S-2 called them Al Qaeda manned cruise missiles. They would come down and just blow up at Iraqi Police checkpoints in the Jazeera area, which was more of a nuisance than anything else. That's about all they could do was lob these things. They were kind of like a V-1 Buzz Bomb kind of a thing. It wasn't going to change the dynamic, except it was costing Iraqi Police and Iraqi Army lives. So, when they put that MEU up there in the Habbaniyah area, that was the end of that threat as well.

So, that was all part of the Surge. They had that additional combat power. So, when people say, "Well, did the Surge matter," well, yeah it did, because eventually what we were doing in Ramadi would have culminated. We might have been able to hold a security bubble around Ramadi, kind of like we did around Tal Afar. You know, I left a battalion up in Tal Afar, which eventually we were able to bring down and replace another battalion that I had in the Jazeera area. 2-37 Armor replaced 1-6 Infantry, but that was really kind of a holding action. We hadn't quite secured the whole area. We hadn't gotten the underlying grievanc-

es resolved, so we were only keeping security through force of arms. And we probably could have done that in the Ramadi area for as long as we remained in the Ramadi area, unless we were able to extend the impact of the Awakening elsewhere.

And that's what General John Allen did and the Surge enabled. I'll be honest with you, I was a skeptic of the Surge. I had said, "Well, what is 30,000 more Soldiers and Marines going to do?" What they did was very artfully enable more of these Sons of Iraq and the Awakening Movement to spread area by area and then that allowed us to hold and then push into new areas. So, by giving us that additional flexibility, we were able to actually make the Awakening take hold and maintain its strength throughout Iraq. So, that's why the Surge worked. [16:39]

Had there been no Awakening, the Surge would not have worked. Another 30,000 guys would have just chased bad guys around the countryside and through the cities and then when we left, they would have gone right back to the way it was. The Awakening couldn't have expanded without the Surge. So, [it was] the Surge and the Awakening together. The Awakening had to happen before the Surge. Fortunately, Al Qaeda murdered Sheikh Khalid [ph] in August, which allowed the Awakening to begin in September, which spread through October and November, which took Ramadi away from the Al Qaeda by December/January timeframe, which then allowed the Surge forces as they came in to spread that through Fallujah and the Baghdad Belts and then ultimately into the city and then north and south. Then, when Muqtada Al Sadr stood up, we were able to knock him down, because we had sufficient combat power on the ground. Sadr's timing, as usual, was terrible, but that's good for us. It's great to be fortunate in your enemies. But, that's how it all kind of worked together in my mind.

The initial part of it that happened around Ramadi would have remained a local phenomenon if not for the operational vision of guys like General Allen and General Gurganus and if not for the willingness to accept risk by guys like General Zilmer and General Neller. I mean, I'll be honest with you. I don't know if I would have been given the latitude to do what I did in Ramadi if I had been working for an Army Division Commander. I'll tell you, I had more latitude than my Marine counterparts had. I think it was because I was from a different service working for somebody else. You know, I was an Army guy working for a Marine. They said, "Okay, we'll give you special Army dispensation, Joint dispensation to go in a slightly different direction, because we don't really know you or understand you as well as we understand Marines." Blake Crowe and Larry Nicholson didn't get that kind of latitude. You know, they were much more under the

microscope. If I had been working for an Army two-star, I'd have been under the microscope. Talk to all my friends who were brigade commanders in Baghdad. They didn't have that kind of latitude. But, by then, the strategic-level vision of General Petraeus, General Odierno, and General Chiarelli had come in, and now nurturing the Awakening and doing these kinds of things was now okay. So, they were able to adopt that template in their areas of operation. But, had they tried to adopt that template on their own, I don't think that they would have been allowed to. So, it was the right place, the right time, right circumstances that allowed this all to happen. In retrospect, people look back and say, "Well, obviously it was a sure thing all along." No, every step of the way it was "Are we going to get the next break?" And we did, we did! [20:20]

Knarr: Two questions, first, how was the Senator McCain visit? [00:00 video 5]

MacFarland: Well, Senator McCain, Senator Lieberman, Senator Collins, and Senator Graham all came over, and it was a great visit. It was a real honor for me. Senator McCain is a true American hero. But, Senator McCain was convinced that we needed to have a Surge. I was a skeptic. He said, "Do you need more troops here, Colonel?" I said, "I need more Iraqi Security Forces is what I really need. I'm developing about as fast as I possibly can." And he said, "Well I think we need 30,000." At the time, I really didn't see why. Now in retrospect, I can see that those 30,000 were absolutely what we needed. We did need more Iraqi Security Forces, but we also needed the additional Coalition forces to enable them.

So, Senator McCain was more right than I was in that discussion. I didn't see it at the time. In retrospect I can see now, but I was pushing back a little bit, and he was getting frustrated with me. He wanted to go out and see the city, too, but his helicopter was due in an hour. I said, "Sir, by the time we get you mounted in HMMWVS get you down in the town, you'll have to go. We're not going to have time to put this all together." So, he said, "Well, I'm going to come back, and I want to walk through Ramadi." He came back on John Charlton's watch, and he actually did get to walk around the town.

That was one of my bridging strategies with John Charlton. We had two. One was on the kinetic side, SQUEEZE PLAY, but the other was on the non-kinetic side. We set up the first Ramadi Reconstruction Conference. At first, the sheikhs didn't want to hear anything about reconstruction. They only wanted to talk about security. Whenever we would bring it up they said, "Too soon." But, eventually, I said, "Listen, I was up in Tal Afar. I saw this big lag between security and reconstruction, which allowed things to backslide

a little bit. We don't want that here. We want a smooth transition between clear, hold, and build." Although we didn't use those terms at the time, because they weren't really enshrined in doctrine or anything like that, this was a little bit before that became the common terminology, but it was the same concept. He [Sattar] said, "Well okay. We'll do that, and you can use my house." So, we did.

My Civil Affairs Marine Lieutenant Colonel, Lieutenant Colonel John Church, set it up. We brought every battalion commander and all the sheikhs in his area of operations into Sheikh Sattar's compound. We held some workshops where we brought in USAID, US Army Corps of Engineers, the Civil Affairs folks, and people like that. We explained to all the sheikhs, "Hey, these are the things that we can do for you. These are the process by which we can do them, and we need your help."

Then we broke out into groups where each Task Force Commander and his local group of sheikhs would sit down and talk about [a plan]. They would say, "Alright, what capability do you have in your area? Which of your friends are engineers? Who owns constructions companies? Who can provide contractor support for reconstruction operations in your area?" Then we planned to have another conference when they would come back and talk about some of their needs. Then there was another conference a couple of months after I was gone. John Charlton and his brigade were there. Also, the Civil Affairs group was not moving out at the same time. They were on a different timeline.

We told them that they'll host the second reconstruction conference when you come back and say, "Okay, these are the projects that we want in this priority order, and these are the people we want you to hire to do it." So, the first and second Ramadi Reconstruction Conference was set up that way as a way for me to transfer my wasta to John Charlton with the same Civil Affairs expertise that I had would help John with his first one. And eventually, General Allen made this into an Anbar Reconstruction Conference, and it spread from there. That was how we kept the ball rolling on the non-kinetic line of operations as well. [5:17]

Knarr: I met with General Allen in March.

MacFarland: He's a brilliant guy.

Knarr: Next question: Colonel Devlin and the Devlin report, your thoughts please?

MacFarland: Here's my take on Pete Devlin: Brilliant guy; always had interesting insights for me; and I did not disagree with any of the specifics. I wasn't even sure that I could disa-

gree with his overall conclusion that Anbar might be a lost province at that time. The difference between Pete and me was that I was actually commanding troops in combat, and I could not let that be true. I had to change the outcome in Anbar. Every brigade in front of me lost about a hundred Soldiers or Marines, and I lost almost that many. I could not go home losing that many American lives for nothing. So, although I didn't say, "Pete Devlin is full of beans or wrong," I went back to my staff and I said, "We have to make Pete Devlin be wrong" or words to that effect. We have to make this report turn out to be incorrect. That was my feeling, and that was my approach. So my reaction was more emotional than intellectual.

In retrospect, everybody said, "Pete you were wrong. You had it wrong. You didn't understand the dynamics of what was going on, on the ground." Like I said earlier, nothing was a sure thing. Pete was one of these guys who came in saying, "Watch out, Sattar may not be a trustworthy guy." Well, I was a drowning man, and somebody had thrown me a floatation device. And Pete was telling me, "Be careful, that floatation device isn't US Coast Guard Auxiliary approved, and it may not hold your head above water." I said, "Who cares. It's better than nothing." I grabbed it and it worked out. So it was good to know what Pete was saying, which was be careful of what you're grabbing onto. I have been and remain a Pete Devlin fan. It wasn't Pete Devlin versus Sean MacFarland.

Now, what happened was, because Pete Devlin was sounding these cautionary notes up at the MEF Headquarters, it was a little bit more difficult for me to convince my bosses to come down and embrace the sheikhs. They were getting a lot of advice of, "Be careful, your job is really to support the governor. It's not really to support these sheikhs. These sheikhs could go rogue on you." I had to overcome that. Those were valid concerns. I don't belittle them at all. But, it did make it a little bit more challenging for me to try to make sure that the Marine leadership in Anbar understood that these guys really can be trusted. "The proof is in the putting, and my soldiers in these tribal areas that have flipped are no longer being attacked. What more evidence do you need?"

Knarr: I don't think anyone has ever characterized this as General MacFarland versus Pete Devlin. I just have never heard that association.

MacFarland: Well, they set Pete up as a foil. You know, like, well Pete was wrong and Sean was right.

Knarr: It just seemed like there was no contact between you two. That was my problem.

MacFarland: Oh sure, Pete and I met at a lot of different occasions and talked about this. Pete could have been right, and I could have been wrong. Things just happened in a good way to make me right and him wrong. It could have gone either way.

Knarr: General Casey. You were moved down out of Tal Afar. And you said Chiarelli was the MNC-I during that time?

MacFarland: Yes.

Knarr: Talk to me about support and guidance from those guys. [10:06]

MacFarland: General Casey was the guy who ultimately decided where my brigade was going to go. From my perspective, it was a painful decision-making process. I just [wanted to know] where I'm going to go fight and battle. It simplified my life tremendously from a commander's perspective, so that I could prepare for it and move out. But, not knowing how long I was going to remain in the AO in the north, whether or not I was going to move to the south, and what I was going to do when I got to Anbar, was a frustrating experience. Ultimately, I think General Casey made the right decision, and I'm glad that he made it. We had to scramble a little bit to make the timeline, but we had enough time to do it. I give a lot of credit to my staff, led by my XO, LTC Pete Lee, who moved the Brigade Combat Team from one area of operations to another through Indian country.

We moved through three to four different division areas of operation to get there, and we did not lose a single soldier or vehicle. And we did not get a lot of support from our higher headquarters, because everybody was busy. They said, "Just move yourself." We got logistic support obviously, but, again, my staff and especially my Support Battalion Commander really did an amazing job of planning that move through hostile terrain to get us there in time and set in order to do a Relief in Place. And we were doing two Reliefs in Place. I left behind a Reinforced Battalion Task Force. I had to support them, because they were a heavy, armored unit, and we left them attached to a Stryker Unit. Well, a Stryker Unit can't support Abrams Tanks and Bradley Fighting Vehicles, so they had to have their own support. How we split our support concept to make all that work was really something that I'm very proud of, and that's really something you don't hear an awful lot about.

Now, General Chiarelli's role in all of this. At first General Chiarelli was focused on Baghdad as the center of gravity. I think we kind of crept up on his peripheral vision. Once he recognized what was happening in Ramadi, he was more than happy to support us. General Dubik from MNSTC-I also deserves a lot of credit. He heard all these rumors that MacFarland is arming these rogue tribes and creating an extra governmental

force. So General Dubik came out and saw what I was doing. Initially, I was just giving these tribal guys captured weapons out of my own stocks. Then I was trying to scrape together whatever I could, wherever I could to arm them. General Dubik came out and saw what I was doing and said, “We’ll support you.” So, there were a lot of folks who, once they recognized the tide was shifting, came in and gave us the support we needed to keep it going. Because, one of the things I was up against was, we were in a drawdown phase. We’re going to start out with eight battalions, but then it’s going to be seven, six, then five and four. I was concerned that we were going to end up losing combat power in Ramadi before we had sealed the deal. So, how was I going to offset that? This was one of the big reasons for my outreach in training the Iraqi Security Forces and everything else. A lot of people forget that.

After one of General Casey’s first couple visits out there, and the same with General Chiarelli, said, “Okay, we’re going to keep you at your current force level” and then later he came in and said, “How would you like additional forces?” So he was reinforcing success, which is what you do. He doesn’t get much credit for that. You know, everybody tends to draw a bright line up to a certain point everything was going bad, then after that everything went well. Well, a lot of the preconditions for what went well had begun to be put in place on General Casey’s watch. I’m not going to argue the merits of Casey versus Petraeus’ handling of the circumstances they had at the time. I will only point out that they had two different Secretaries of Defense and that mattered. [16:00]

Knarr: You are absolutely right. Lioness Teams—did you start that?

MacFarland: Well, I don’t know who else might have had them.

Knarr: I understood it was brigade thing.

MacFarland: It was. One of my young lawyer captains, Stephanie Cooper, was a leader of that effort. We knew that we had to have female soldiers and Marines to do security pat-downs. I don’t remember if anybody had ever done Lioness things elsewhere or recall that term being used any place prior to our doing it, but...

Knarr: I thought it was kind of neat.

MacFarland: Yeah, but we did it, and it worked out well. Those gals were very courageous and went out in harm’s way and did what needed to be done.

Knarr: You had described the 9 September meeting where you met Sheikh Sattar, and then you provided some good descriptions of the 14 September meeting. Could you...

MacFarland: I'm trying to remember...

Knarr: I guess 9 September is when you first met with Sattar. And on 14 September Sattar had the press there to announce the Awakening.

MacFarland: The two blend together in my mind, but yeah, when they announced their 11 points, it felt basically felt like they came out with their Declaration of Independence. They were pledging their lives and their fortunes, just like our founding fathers did, literally! And Sattar paid with his life for that. That's a name that people should never forget is Sheikh Sattar Abu-Risha. What a courageous guy! Where would we be today without him? I don't know!

Knarr: Thank you for your time and perspectives, it's an honor. You guys did an incredible, incredible job!

MacFarland: My pleasure.

19 May 2010

Subject: Interview with Mr. Sterling Jensen, Interpreter for Coalition forces in Ramadi from May 2006 until June 2007

Mr. Sterling Jensen was a contract interpreter for System of Systems Integration, under L3 Communications in Ramadi from May 2006 until June 2007. He linked up with the 1st Brigade Combat Team, 1st Armored Division (1st BCT/1AD) in Tal Afar in April 2006 and moved with the Brigade to Ramadi in May. He primarily worked for Lieutenant Colonel Jim Lechner, Deputy Commander, 1st BCT/1AD. When 1st BCT/1AD transferred authority to 1st BCT, 3rd Infantry Division in February 2007, he remained and worked for Colonel John Charlton, the Commander, and LTC Thaddeus McWhorter, the Deputy Commander.



Mr. Jensen was interviewed by Dr. William (Bill) Knarr, LtCol Dave Graves, USMC, and Ms. Mary Hawkins on 20 October 2010 at IDA. The following is his account of the Awakening.

Dr. William Knarr: Can you start off with your name and your background?

Mr. Sterling Jensen: Sterling Damir Jensen. I'm from Mesa, Arizona. I'm 33 years old. I got interested in Arabic in '99. I did a study abroad, a program in Jerusalem. I was at the Brigham Young University, a satellite campus there. I'm a Mormon. And so I just got interested in Arabic. I wanted to work for the State Department. I started learning Arabic, and then went to BYU. I did an Associate's degree in Arizona at Mesa Community College. I then went to BYU, starting taking Arabic, and September 11th happened. I continued with my studies and graduated with a Bachelor degree in International Studies in 2002. I went to London and worked at the London Science Museum, but while I was there was when all the Iraq stuff went on. I was thinking about studying in Syria, but then when the war started. I decided not to go there. I ended up going to Morocco for a summer and doing just an Arabic Program. Then I went back to the States and BYU asked me to be a facilitator for a group of BYU students in Syria. They had gotten a grant from the State Department to do a pilot type of program to see what it would be like, because they were starting to get a lot of money for Arabic

language acquisition. So, I went there for six months. It was a very good program. You had class four hours a day. I went back to London after that, and I worked for an American lawyer there. I still continued with Arabic trying to get to know the Arab community better. Then I got a Boren Fellowship to go back to Syria.¹ BYU is on a panel of U.S. universities that do strategic language teaching. Because the program that we had done in 2003 was successful, I think DoD [Department of Defense] and others threw in a lot of money to do a Flagship Program in Syria. I was part of the first group that went as part of the Flagship Program. It was a year program at the university, and I did that for a year. I lived with a family, and went all around Syria. That was 2004 to 2005.

After that, I came here to Washington, DC. I was interested in either working in intelligence or still the State Department, but after talking to people, I felt like I needed to get my Master's degree. I didn't have any money, and a friend of mine who was in Air Force Intelligence said, "Look, if you need money, be an interpreter. Go to Iraq for six months, and make your money. Come back and get your Master's." He's like, "You'll understand the U.S. Government more there than you will here. And since you're not an Arab and you speak Arabic, everyone will want to be with you. They'll treat you like gold!" So that's what I did, and that's exactly what happened.

I went to Iraq through SOSI [System of Systems Integration]. They are a subcontractor for L3 Communications. I was assigned to 1st BCT/1AD that was in Tal Afar. Colonel Colonel Sean MacFarland, the commander, gave me to his Deputy, Lieutenant Colonel Jim Lechner. Lechner was doing ISF [Iraqi Security Forces] and tribal engagement and doing all that type of stuff for MacFarland. MacFarland wanted to focus on the troops and operations rather than doing the drinking chai thing, so he gave that to Jim Lechner because Lechner had been a MiTT [Military Transition Team] Advisor in Samarra in, I think, 2004 or 2005. So, I was with Jim Lechner and that's when I got to know Mayor Najim [Al-Jabouri, Mayor of Tal Afar]. I was with them for about two months. I got there in early April 2006 and worked with Mayor Najim for about two months. Then Lechner said that they were assigned to go to Ramadi and asked me if I would go with him, so I went with them to Ramadi.

¹ "Boren Fellowships are funded by the National Security Education Program (NSEP), which focuses on geographic areas, languages, and fields of study deemed critical to U.S. national security." Extractd from http://www.borenawards.org/boren_fellowship on 6 January 2013

We got there, I think, in late May 2006. So I was with Lechner all through the summer, all through the Awakening. They were scheduled to leave in January. I was going to quit in December to try to go to school, but that's when Travis Patriquin [Captain, U.S. Army, 1st BCT/1AD staff, tribal advisor to COL MacFarland] was killed in December. Him and I were pretty much the only ones that talked a lot about what was going on with tribes from a brigade level, and so I just kind of felt like I needed to stay. So I stayed. And then [1st BCT/1AD] got extended until February. When 1st BCT, 3rd Infantry Division (1st BCT/3ID) came in, Lieutenant Colonel Thaddeus McWhorter [Deputy Commander] and Colonel John Charlton [Commander] asked me if I would just stay a few extra months for continuity. I had been accepted to John Hopkins' SAIS [School of Advanced International Studies], and so I decided to stay with them until my summer school started. [5:25] I stayed with them for about four months, and helped them with their continuity relations with Sheikh Ahmed [Albu-Risha] and Sheikh Abdul Sattar [Albu-Risha].

I started SAIS, and during the first semester was when Abdul Sattar was killed and Sheikh Ahmed called me. I talked to him a couple of days after, and that's when I wrote to the op-ed for Washington Post.² I had a teacher at SAIS that was on the National Security Council [NSC], and she was dealing with Al Qaeda and extremism, Mary Habeck. We just got to know each other and for some reason she just said, "Oh my gosh, you know these people personally! I just finished writing this paper for the NSC about the Awakening. There are people that you need to talk to, because we don't know what it means that Abdul Sattar has been killed now. And you're having this personal relationship with his brother who has now become the head." And I said, "Well yeah, I just talked to him, and he's going to be coming to the States. I'll see him in a couple of weeks." And so anyway, she got me in contact with MCIA, Marine Corp Intelligence Activity.

Knarr: Who got you into it?

Jensen: Mary Habeck, she was NSC. And so she got me in contact with the MCIA. I went and visited MCIA. They invited me over there and just basically said, "Look, we want to hire you. We want to send you back over there as a FAO [Foreign Area Officer]. The

² Sterling Jensen, Lessons from an Anbar Sheikh, *Washington Post*, Op Ed, 29 September 2007, accessed at http://www.washingtonpost.com/wp-dyn/content/article/2007/09/28/AR2007092801554_pf.html on 3 January 2013.

brigade's leaving. You know how relations are with the Marines, and we just want to make sure that the relations are smooth. We're going from a brigade to a battalion and if you could be over there. You know Sheikh Ahmed, you know the rest of these guys; it would just kind of help us out." So, I did that. I went over for six months and basically worked on the governance cell and was doing action officer engagements for the government cell with the PRT [Provisional Reconstruction Team]. So, since I could call Sheikh Ahmed or the rest of them whenever I wanted to do appointments, I could get them over there easy.

Unfortunately, at the time the Marine Command had made a decision to not visit Sheikh Ahmed, because it was coming up to the elections and they were trying to go a different direction and because the Provincial Council was being very sensitive. They didn't like all these visits, and they were trying to take credit for certain things. It was kind of this transition time. Anyway, it didn't end up sticking. I'm like, "You're smoking pot if you just stop. You've got to remember who your friends are. If you don't, it could get worse." And so when things got bad, Major General John Kelly ended up visiting Sheikh Ahmed a little bit more, and Brigadier General Martin Post [Deputy Commanding General MNF-W, February 2008 to February 2009] would visit him every once in a while. Anyway, I was there for that, right before their change of authority ceremony.

Then I came back, finished SAIS, and graduated from SAIS. Then I've been working at National Defense University with Najim Al-Jubouri, former Mayor of Tal Afar. He doesn't speak that much English, and so we wrote a paper about ISF.³ One of the recommendations was about strategic communications and [how] the U.S. is not very effective at it. A few weeks after publishing it, I got a phone call from one of these contractors that do this over there, and was hired to go back and forth and help them with that. And so, I've stayed at NDU as a Research Associate, but on a part time basis and then I go to Iraq.

Knarr: Ok. Let's go back to Tal Afar. It's 2006, and you were with 1AD, COL MacFarland. You're moving down to Ramadi in late May. What were some of the lessons that you took down to Ramadi with you? [9:30]

³ Najim Abed Al-Jabouri and Sterling Jensen, The Iraqi and AQI Roles in the Sunni Awakening, Prism Volume 2m, Number 1, December 2010, accessed on 6 January 2013 at <http://www.ndu.edu/press/iraqi-aqi-roles.html>

Jensen: Well, I was all new at this. President Bush had just given the speech about “clear, hold and build,” and the next day Mayor Najim’s house blew up. So they knew that Tal Afar was a big deal. They knew McMaster [Colonel H.R. McMaster, Commander, 3rd Armored Cavalry Regiment – 3 ACR] was part of it and they [1st BCT/1AD] were at the tail end of it and so [from their experiences] there was a lot of confidence going down to Ramadi. I remember talking with Patriquin, Lechner, and the rest saying, “Look, Ramadi is like Tal Afar was last year. It’s going to take us a while to do it, but we’re going to change this thing.” Like I said, I was just kind of this new person. I knew that Ramadi was a bad place. I didn’t know what to expect, but we went down there and the brigade that was there; I forgot...

Knarr: Part of the 28th Division?

Jensen: Yeah part of the 28th. Since I’m Mormon, I got to know these people at church. There was one of the guys that was head of the CAG, Civil Affairs Group. I think his last name was Bramwell, and he was a Lieutenant Colonel [LtCol Mark Bramwell, 3rd Civil Affairs Group]. He was Mormon and so we would talk a lot. He said, “Look, your guys are way too cocky! Way too cocky! You’re not even asking the brigade that’s here what’s going on. You know?” And in my conversations with Lechner, he was like “Look, they hunkered down. They need to get and engage with the Iraqis...” . There was a sense from the Marines as you would talk with them and from the [2nd Brigade, 28th Division] brigade that, “Who’s this Brigade coming in town thinking that they’re going to change all these things?” And there was that sense of cockiness and sense of confidence. We’ve just come from Tal Afar; we’re active duty; we’re going to change this place, because we know what’s going on, you know, type of thing.

And so that [confidence] was reflected when we went out. Lechner was out all the time, since he was the one doing the ISF issues. We had to try to recruit police. Every day we were going down [Route] Michigan and all these places. At the beginning we weren’t getting hit very often. We’d get an IED [improvised explosive devices] or something like that, but no one would get injured, and when no one gets injured then you don’t take as seriously [as if someone was injured]. It wasn’t until Captain West was killed that we took it more seriously.⁴ For about a month and a half as they’re trying to prepare the operations. We didn’t get any police from Mosul. We didn’t get any National Police.

⁴ Captain Jason M. West was killed in action on 24 July 2006 in Ramadi.

The unit that came from Mosul, like a third of them came and they didn't want to go out, and so MacFarland had to change his plans.

During this time, I'm observing all this, and my feeling is we've got to be friends with the police type of thing. Major Ted Gates was the Marine LNO [Liaison Officer] for ISF recruitment, and he was big on that. He was a former police officer, and so I would go out with him. I would go out with Lechner. Like I said, at the time we were just trying to do police recruitment. That was the big thing in my life. Coming from Tal Afar, I didn't know of any lessons learned or anything, because I am just a civilian. I'm new, and I'm an Arabist. I just spent a lot of time with Patriquin, and we would talk about Arab things. We didn't talk really about operations. We would talk about the sheikhs. We'd talk about the tribes..."Ok let's try to map out the tribes, and let's try to find out who's who."

About two or three weeks after we got there, this would be the end of May beginning of June) Lechner brought in Ted Gates [who] suggested that we "Build a police station in the Jazeera area where the police are from, because no one is showing up. If they don't show up we can't give them pay. We can't get equipment." We need all that because there were nine official stations in the city. So he's like, "No one will go to those stations, because they'll get caught, and they'll get killed. If you build this police station in the yogurt factory," which was in the Albu-Thiyab area of the Jazeera, he's like, "They'll go there." Well we went and visited it, and the next day it blew up. Lechner asked Gates, "What do we need to do?" He's like, "Look, we still have to build it. Let's do the water station." So Lechner said, "Ok, let's do it then. I will totally support it." And so they built that around early July when it finished, so it was around that time that we're still trying to do police recruitment. [15:07]

Knarr: That's the Jazeera station right across the bridge?

Jensen: Yeah, right across the bridge. Yeah, and the first recruitment drive I went to was at the glass factory. There weren't very many people that showed up. They had had the incident in January where a suicide bomber killed a lot of people, and so a lot of people didn't want to go to the glass factory. Tony Deane was talking with Sheikh Ahmed and Abdul Sattar, and they said, "Look, don't go to glass factory. Come do it at my house." I wasn't in that meeting with Deane. Lechner and Gates came to me and Gates said, "Hey there's going to be this police recruitment at this sheikh's house. We're going to go." First of all, I went to visit Sheikh Sattar's house because he was talking about doing recruitment. I went with Gates. Sattar had this big meal, and it was the first time I met

him. We have it on video. At that time, the Company Commander kind of owned Sattar; it was more of a Company Commander engagement rather than a Deane [battalion command] engagement at the time. Deane would visit, but it was the Company Commander that did all the stuff with him.

Knarr: You say you have this on video?

Jensen: Yeah. There was a combat camera girl, Amy Foresight. I have it. She filmed it all, that first meeting that we went over to Sattar's house. It was interesting, because now in hindsight, Sattar had already planned out what he wanted to do. Not totally; but he had a good idea of what he wanted to do. The dates will be on the video, but it was either late June, early July that we went over there. Amy Foresight, the combat camera girl, said, "Hey, I can get this feed out to the Arab stations. Does he want to say anything to the Arab stations?" Sattar's like, "Oh, oh, yes I do!" and he told the guys that were with him, "Hey, we're going to be on Al Arabiya tonight." He said, "I'm Sheikh Abdul Sattar Albu Risha a Sheikh of the Dulaym, and we're fighting Al Qaeda right now. We invite all the tribes and all the tribal leaders to come back from Jordan and Syria, because we're going to beat Al Qaeda. Anyone who wants to help us to fight Al Qaeda, we're going to accept them." This is before they announced the Awakening, ok, so it was kind of a bold type of statement. The Company Commander said, "Delete that. He'll get killed if you release that!" And so she didn't show it. She made her own little thing for the military, but she didn't send the feed to the Al Arabiya, the Arab channels.

There were things going on that we didn't know were going on. When we arrived, we saw people that were on our target list, showing up dead in the streets. They'd have these signs saying, "This is what happens when you mess with the Anbar Revolutionaries," type of thing.⁵ We didn't know who was killing them. I remember talking with Lechner one time. He brought Patriquin and I together, and he said, "I think such and such three letter agency is doing this. But who knows, we didn't know who was doing it." But see Sattar and Tariq talked freely about it, that they were the ones that were doing this type of stuff. Well they're from the Albu-Thiyab area, and that's when we were recruiting police. That was when he was talking with Colonel Walrath [LTC Dan Walrath, Commander 1st Battalion, 6th Infantry]. They were like, "Ok, we'll do police

⁵ Anbar Revolutionaries, anti-AQI group. Najim Abed Al-Jabouri and Sterling Jensen, "The Iraqi and AQI Roles in the Sunni Awakening," *Prism* Volume 2, Number 1, December 2010, accessed on 6 January 2013 at <http://www.ndu.edu/press/iraqi-aqi-roles.html>

recruitment.” Then Tariq went around to the guys that had been doing Thawar al Anbar [TAA] type of stuff, in that area, because Thawar al Anbar had been happening in Fallujah and happening in Karma, but we didn’t know. This is hindsight. Tariq then gets all his guys to join the police. Whether they were part of the police, he gets them to then work in the Jazeera Police Station. So, as more and more guys were coming to the police station, we were able to give them more and more PKCs [machine guns] and ammunition. And we started giving them vehicles. Lechner was always in contact with BrigGen Neller, saying, “Sir, I need vehicles.” These guys love the vehicles. The second they got their vehicles in the Jazeera, they turned on the lights and they’re all over the place. And so that was like the golden thing, PKCs and vehicles. That’s the two things that they wanted, mainly. I mean they wanted food and everything, but they wanted mainly that and then pay. If you can get them a PKC and a vehicle they would be happy. [20:16]

Knarr: How does this link up with the events in Jordan? We talked to BrigGen Reist, and he talked about the conferences in Jordan and engaging with the sheikhs in Jordan. Now you’ve got an Army Brigade that comes down and starts talking to people on the ground like Sattar. What did BrigGen Neller say? What did LtGen Zilmer and those guys say?

Jensen: At the time, I was in meetings when Reist or Neller would come and talk about ISF. Not really Reist, more Neller. I was in a lot of meetings with Neller and just a couple were with Reist. I would hear MacFarland and Lechner’s point of view of what the Marines were doing. Now Sattar would talk a lot about the tribal leaders in Jordan and he would say, “Why are you guys supporting these guys? They’re not doing anything for you.” So he would talk about Jordan. He would talk a lot about the Provincial Council. He’d talk about the IIP, the Iraqi Islamic Party. In hindsight, after working for the MEF [Marine Expeditionary Force], I understand more kind of what was going on, but at the time, the sense was that the Marines are supporting these people that Sattar doesn’t believe deserve their support [because they fled to Jordan]. Well, MacFarland didn’t have anyone else to work with. I think it was a blessing in disguise that you had an Army Brigade working in a Marine Division. Had it been a Marine regiment, you would have had General Zilmer say to the regimental commander, “Cut this out. We’ve already tried this. You’re going to get a lot of people killed, and it’s undermining our efforts at the Provincial Council.” Ok, if it’s an Army Division with an Army Brigade, and even MacFarland will say, there’s no way Mosul would have let us do our own little initiative

like this. But I think because of the respect thing, because of Zilmer not wanting to tell the Army what they have to do, you know, I think he just was like, "Ok, do your thing."

Knarr: Interesting point.

Jensen: Anyway, they wanted their own helicopters. They didn't want the Marines to use their helicopters. They didn't think Marines would take care of [them]. There was bad talking between the two. It fed into dialogue with Abdul Sattar. Zilmer or Reist brought Mamoun one time. It was right when Jim Soriano [State Department, Head of the Provincial Reconstruction Team] came; it was like in October after the Awakening started. MacFarland's point of view when we were there was, we'd go visit Mamoun, but he's the governor of the Province. We don't have a Mayor. We don't have anyone to help us, but he [Mamoun] wanted to do everything that was in Ramadi, but MacFarland [knew] it was not in his realm of responsibility; that's the MEF's responsibility. He can't go engage the governor. He can't ask the governor to get him stuff. You know?

And so, Sattar comes along. Right when the Awakening was announced, I remember going up to Colonel MacFarland right after and asking, "What do you think?" All these Sunnis want to be our friends. This is awesome. "What do you think?" And he's like, "I'm going to support it. I've got no one else to work with. We have to be careful with it, but we don't have anyone else to work on. We'll support it." From that point, we were visiting Sattar almost every other day. It was all connected to police recruitment. Neller understood that. I saw it through Lechner, that he had Neller's ear. Neller was ISF, and if these guys were bringing thousands, hundreds of recruits, it was ok with him. He was going to try to do what he could. He wanted to make sure it was within the police stations.

Now a lot of the misunderstanding came between the Provincial MEF people and the brigade about the police stations. We had to coordinate all of our papers through them [the MEF], and they would take it to MOI. Well, when they're [Iraqis] not getting pay, and we're not getting stuff, Lechner's asking, "Why?" We had nine official stations in the city. The Marines were concerned that we were making our own militias and would ask about the various stations that weren't part of the official list. [25:40]

We would go around, and it was like almost like a mafia type of style, trying to get these guys paid or trying to get them their things, because these aren't official police stations. On the records, we would link them to an official station. Well, the problem was that the police didn't always understand that. They'd get their rosters, and they would say, "I am

from this and this police station.” We would give it to the Marines at Blue Diamond, and they would be like, “Never heard of this police station. We can’t pay them.” Lechner would say, “These are official people. They’ve come back from Jordan. They’re working out in these outside areas. They’re all connected to official police station [they were justified as substations]. They need to be paid!”

By October/November, as things are building up and [we are] getting more and more recruits back; MEF wants more of these recruits. The recruits are motivated because they think they’re going to work in their local areas. Well, as they’re coming back, MEF is trying to dig into it and say, “No, we want these policemen, they are needed over here.” Then we talk to Neller, and he tells them that they can’t take the Ramadi police. And so, this is all part of it as well.

In hindsight, it was interesting to talk to all these people—Sheikh Ahmed, and the rest of them—felt like they weren’t going to lose anything because they were tied into the brigade. Faisal al Gaoud was there to announce the Awakening with Sattar, but he split with him. Sattar was tied in to the brigade for support but the other tribal guys like Ali Hatim had been tying for two years previous with the MEF and not getting anywhere. The MEF wanted to do it, but they [were having a hard time], because they needed higher approval and couldn’t get it. They either had someone from policy or somewhere saying, “I don’t want you to meet with these guys. I don’t want you to talk about their militias or whatever. We’re not going to do tribal engagement.” But you could do it at a brigade level. Sattar saw that he got the support that the bigger fish were trying to get, but couldn’t. They couldn’t get the support, because first of all they’re in Jordan. They’re not on the ground in Iraq, but Sattar was on the ground and could influence the action. People then turned to him. Ali Hatim, for example, wasn’t there at the time. He was in Baghdad helping with stuff.⁶ When these guys would go to Baghdad, he would help facilitate meetings to go over to Maliki, Sa’dun Dulaymi [Minister of Defense], and to the other Ministries. He would help out with those types of things. [He was a] very anti-Islamic Party type of person, ok, but he connected with these guys in Jordan and in Baghdad. [29:34]

⁶ Sheikh Ali Hatim Ali Sulayman al-Dulaymi al-Assafi was the Shiekh General of the Dulaymi Confederation. His uncles shared leadership of the Confederation but Ali Hatim managed its the day-to-day business. Sheikh Ali Hatim interview with Dr. William Knarr, Colonel Dale Alford, USMC, and Lieutenant Colonel David Graves, USMC in Baghdad on 24 April 2010.

But, if Ali Hatim came to Ramadi in late 2006, and told people from his own tribe, Abu-Assaf, "I don't want you to work, because the Americans aren't letting me go on Blue Diamond," they wouldn't listen to him. They would listen to Sattar. If Sattar said, "I'm holding a meeting at my house," and Ali Hatim said, "I'm holding a meeting myself at my house," and it was the exact same time, more people from Ali Hatim's tribe would go to Sattar's house for the meeting, rather than Ali Hatim's. Sattar got the Americans, and they wanted to be with the Americans. They wanted contracts; they wanted police stations in their areas, and Ali Hatim couldn't get that.

The Marines try to balance it, because they see all these positive things that are happening, but at the same time they're not able to control it. That then blows up when 1st BCT/3 ID comes. That's when Petraeus then comes and is briefed. When he's briefed in February, he hadn't heard about it. He turned to MajGen Walter Gaskin, Commanding General, MNF-W, who's a brand new guy, and MajGen Gaskin is like, "Sir, these are small fish. This is a road thief." MacFarland said, "Sir, I've read all the reports about Sattar. I know what's out there. I suggest you just visit him. Visit him, and get your own view from visiting him." MajGen Gaskin is like, "Sir, I don't think that's a good idea. I wouldn't do that. We're working the Provincial Council. He's a small sheikh, and someone of your stature going to visit him is going to undermine a lot of things." Petraeus told Gaskin, "No. I just finished writing a counterinsurgency manual. This is a very positive development. You need to support this."

It was after that when BrigGen John Allen [Deputy Commander, MNF-W] visited Sattar. I was at that meeting when Allen visited him the first time. Allen was very, very explicit. He said, "I am visiting you as a social leader, not a political leader. You are a part of a tribe and part of a movement." And he tried to distance himself. But this is when the MEF started buying into it a little bit more. They were buying into the ISF part, but they didn't want to show that Sattar was any type of political leader, because that was undermining the Provincial Council.

Knarr: Well this was in March 2007?

Jensen: This was in March. Yeah. The second that Petraeus comes, he starts sending General Ordierno. So Ordierno doesn't tell Gaskin when he's coming; he just shows up with reporters. Well, what does Gaskin do then when he's talking with the Provincial Council and the Islamic Party, who he's supposed to support? And the tribal leaders in Jordan are saying, "This guy's getting all this air time. What's going on?" Well Gaskin can't tell

General Ordierno, “Don’t come visit Sattar.” So, what do they want? They want to make sure that they bring it under Marine control.

Knarr: Now when did you leave?

Jensen: I left in June 2007 and then came back in February 2008.

Knarr: Ok, that’s just when COL Charlton was leaving.

Jensen: I was there his last month. So I stayed with them. Captain Press was the Intelligence Officer at the Brigade that was doing a lot of the things with Sattar, he kind of took Patriquin’s role. The other thing is Charlton is very different from MacFarland. Charlton did a ton of the engagements. MacFarland didn’t do a ton of the engagements. He would show up if Lechner said, “I want you to show up.” You know, if we needed a certain thing or he might go out just to say, “Hi,” but he wouldn’t do any of the Action Officer Engagements; Lechner would do that. Well, Charlton comes, and he’s at Sattar’s place all the time. McWhorter would also go, but it was mainly Charlton that drove it. The other thing is that MacFarland was losing a lot of guys. Charlton wasn’t losing a lot of guys. MacFarland was thinking about soldiers and operations more, trying to get these combat outposts inside the city. He delegated, and said, “Lechner, you just take care of it. Just let me know what I need to do.”

And so Charlton took it. I got there a month before they were leaving. I met with Charlton, and I met with Captain Press. I’m like, “Ok, now I know I am working for the MEF, what’s going on.” And they’re like, “We’re doing all these former regime engagements. We’ve got all these guys. These are Major Generals. There is a former Head of Infantry, but the Marine General or his one star hasn’t visited these guys.” So I started going on some of these engagements with them, and we’d bring like a Major from governance or whatever, but then it built up. Major General Kelly ended up wanting to support this type of thing, because we did a big conference and took pictures of it. General Petraeus was like, “This is the best thing I’ve seen MEF do.” [34:53]

Knarr: When was the conference?

Jensen: July 2008

I mean I’ve skipped all over the place, but this is kind of...

Knarr: No, no; that’s okay. I’m tracking. I’ve talked to Brigadier General MacFarland and I’ve read a lot of the material. I see COL Charlton at noon oday and so I’ve put most of this together. My son had a Company in the Engineers with MacFarland.

Jensen: Oh really?

Knarr: So he was right there at the...

Jensen: at the Jazeera, yeah, yeah; the Engineers were doing a lot of great work, because they were building not just the cops, but also the police stations. And so they'd bring out all the HESCOs, and we'd be out in the middle of nowhere. They'd make these places, and it would be really good, you know?

So, now MacFarland has toned down a little bit. He's a general, and he has to be very diplomatic. But from the Marine's point of view, they let it happen. They could have pulled the plug, but they didn't even though they may have wanted to. That's where I give Zilmer credit.

Knarr: And Neller?

Jensen: I think Neller was great, because Neller was visiting. He would go visit the stations, and he would listen to Lechner. [38:35]

Jensen: [Thomas] Ricks, of *Fiasco*, wrote an op-ed in the *Washington Post* on September 11, 2006. It's the one where he says, "A Marine report says that Anbar is totally lost." You know? I go in the office, and I'm like, "Did you guys read that article?" And Patriquin remarks, "Those Marines. Their intelligence people never ask us questions. They never even visit us!" Now remember we're very cocky at that time, even before the Awakening started. So the Awakening was going to be announced pretty soon, but we'd already been meeting with these tribal leaders. We were getting more and more recruits, so it only fed our cockiness. So, we're feeling like this is the greatest thing that's going on.

Knarr: You were well on your way, you felt?

Jensen: Yeah.

Hawkins: What about Sofia?

Jensen: Oh yeah, like the Battle of Sofia and Sheikh Jassim?⁷

Hawkins: Can you talk about that? [44:43]

⁷ Sheikh Jassim Muhammad Salih al-Suwaydawi, contesting sheikh of the Albu-Souda tribe in Sufia. Interviewed by Dr. William Knarr, Colonel Dale Alford, USMC, and Lieutenant Colonel David Graves, USMC in Ramadi on 9 April 2010.

Jensen: Ok, in July and August, as we're doing this police recruitment and we build the Jazeera station, Sattar wanted his station as well. Lechner's condition was you have to send people to Jordan. If you can give me recruits, even if it's like five or six or seven or eight, I can then justify building something in your area. So that was the deal. Everyone came. We'd go visit Sattar, and you'd have a sheikh and you'd have a list of 30 names. [The sheikh would] say, "I want to build a police station." Lechner's line was always, "Ok, we're having a recruitment drive next week. Bring your guys. If they go out, I can see what I can do."

Well, Sofia was the hot area. Sheikh Jassim would visit Sattar, because he needed money and ammunition. He needed weapons. I've got it in my journal, but it was probably either late July or early or late August when we went over to Sattar's house and Sheikh Jassim was there. Sattar says, "I've got this guy from Sofia." Well that perks Patriquin's ears, because Patriquin was working with all the Intelligence Officers. He'd go back and then he'd talk with the agency or whoever it was to try to coordinate.

Part of the reason why Sattar liked Patriquin is because Patriquin would go in there with names off the target list and say, "What do you think about this person or that person?" Sattar would say, "Look, don't go against this person. I can influence this person. I know he killed Americans, but I can own him. Just don't go after him right now." [He would say,] "This person is bad" type of stuff. Sattar felt like he had a lot of *wasta*, influence, because he felt like he could have some control over it. And so, Jassim comes. He knew that Sofia was a hot area. We knew that we wanted a presence, but it would be very difficult. We didn't have a station near Sofia with any type of presence that we could say, "Oh we've got a station over there." And so, Jassim talks to us, and says, "Look, I'm surrounded. I'm at the little tip of Ramadi [Shark Fin area east of Ramadi]. I've got my 15 guys" or whatever it was "and I need weapons. I need ammo. I don't have anything." Lechner tried to tell him, "Look, there's an Iraqi Army [IA] post right across the river. Just go across the river." He's like, "I'll get shot. They don't know who I am! They're going to kill me." And so we went over to the post to tell them to coordinate to help Jassim. Well it didn't really happen.

Jassim came again. And Patriquin is like, "Hey let's try to help this guy." I think we gave him some ammo or something like that on one of these visits. And so we'd been back and forth with him and then in September or early October, maybe it was even November, Patriquin got a phone call on the Thuraya from Jassim. He is saying, they're getting wasted out there, and we're seeing it on the UAVs [unmanned area vehicle]. So

we called Sattar. Then we called Jassim and said, "Ok. We're going to go over there." Now MacFarland wasn't there at the time. Either his XO or Lechner assumed command. LTC Ferry, the battalion commander who was responsible for the area was told, "Stop your mission." Colonel Ferry had a mission in the Mula'ab area [East Ramadi], and so Lechner said, "Stop it. Go and secure the road, and let's go help this Jassim guy."

And so we went over to Sattar's, and we got a lot of ammo and guns; a lot of them had been confiscated guns. We got a ton of it! And then we went up to Ferry, who had just gotten there and secured the road. We went up there and gave them all these weapons. It was like Christmas! I mean, we went in the house, and there are these guys [who had seen] all this crap during the day. They'd been working really hard. They lost a couple of people. His [Jassim] sister was dragged by a car. [49:04] I think at the time it was like maybe 50 or 60 [enemy killed].

Hawkins: ...against 15.

Jensen: Right, it was a big deal at the time! We told Jassim that first time we met him, "We're happy to help you, but the only way we can help you is if you help us. And you can help us by sending some of your guys to Jordan, because once they get back, they can be official. They'll be official guys. We can't pay them out of our pocket. We're not paying any of these guys out of pocket."

Their assumption, and this feeds into what would later be called the whole Sons of Iraq Program, they assumed in other places that we were paying them. This started in about February. We'd go visit Sattar's house, and Aifan Sa'dun would show up. He was like, "Convince the Americans to help me in my area, because you're helping Sattar. We want the same type of help, and we're fighting Al Qaeda. We're all anti-Al Qaeda." Well, Lechner would be like, "That's the Marines. I'll try to talk to them, but that's out of my AO. I've no influence." We'd get people from Baghdad and Salah ad-Din saying, "Convince the Americans in my area to do the same thing that you're doing."

So Petraeus came and said, "Well, let's try to support this." He had all these problems in Amariyah. They had all these people that wanted to sign up to do the police, MOI. It was a political threat to the Dawa, it's a political threat to ISCI [Islamic Supreme Council of Iraq], so they're not going to support it. MOI and Maliki supported the Awakening in Anbar from the very beginning. It wasn't a political threat. You know? The IIP was boycotting the government. They were saying all this crap. You've got this new guy that's fighting Al Qaeda and saying, "We'll work with the government, and oh, by the

way, I hate the Islamic Party.” So Maliki is like, “Ok, let him do it! That’s no problem.” Well, once it’s in Amariyah and Baghdad, and you already have an established police that is working for ISCI, they’re not going to let these guys join the police that’s in General Petraus’ Sons of Iraq Program.

Well, a lot of these guys joined the Sons of Iraq Program, I think, because they assumed that in Ramadi and in Anbar, these guys were getting paid by the Americans. And their argument [for joining] was because they were fighting against Iran and Al Qaeda is helping Iran. So, it was the same type of thing in Ramadi. So, Jassim and the rest of them are thinking, “build a station” while we’re saying, “Take your guys to Jordan, and come back, because it all has to be done through the MOI.” Jassim was like, “I can’t send any of my men to Jordan. I rely on them. I’ve only got 15 guys. If I send three or four of them, we’re dead meat!” And so that’s the reason why we didn’t build anything over there. After Sofia, we felt like we could justify it, because things had already built up. It wasn’t as sensitive in November as it was in August/September. Because it was a strategic, sensitive area, Special Forces with the help of the IA, built a post out there. And this General Abdullah, ok, that was the head of...he took Razak’s spot. He was a Sunni as well...

Knarr: Well, Adel followed him in then didn’t he?

Jensen: Yeah, Adel followed him. Adel was his deputy. Adel is great. He was his XO. And so, Abdullah is now head of 1st Division, he took over for Tariq or whoever it was.

Knarr: Yeah, yeah, I think you’re right!

Jensen: When Abdullah came in, he was like, “I’m going use the tribes. We can exploit this.” And he would go up and give all these speeches. They loved it! He gave great speeches. At first Lechner didn’t like him, [but then he] would hear his speeches and he was like, “Dude, we need to take him around and give these speeches all over the place!”

Knarr: This was who?

Jensen: This was Abdullah. He’s fantastic, big fat guy!

Knarr: Yeah, I saw pictures of him.

Jensen: Anyway, in November, he then goes up and says, “I’m going to support him. I’ll do it.” So they put an IA post up there, and then Jassim starting helping Special Forces a lot going through helicopters and pointing out places. They worked very closely, and so they were able to secure it. That’s basically what happened. Then when Charlton came

in February, we wanted to expand out to the Albu-Fahad area. We still weren't out there, and that was further east of Ramadi. So it's this idea of the corridor...

Knarr: East of Sophia?

Knarr: Julaybah Area.

Jensen: Yeah, Julaybah, and then you've got Haldia and those areas are right there, and up to the Habbaniyah base. And so anyway, we were trying to move out there, but the Albu-Fahad is like the mother of tribes in the area. Sattar is not a mother of tribes, and so it was sensitive because the Albu-Fahad has all the former officers. They were supporting the Awakening, but Sattar knew that if they started jumping on ship in the Awakening, they would be able to outdo him. And so Charlton, right when he got there, within a couple of weeks or three weeks, he wanted, to go east. When we would visit Sattar he'd be like, "Hey, Sattar get me in contact with the Albu-Fahads. We want to talk to them, because some of them are talking to us. We want to start moving out there." Sattar was vacillating a little bit. What ended up happening is, in February, they did a meeting and Jassim helped coordinate it. We went to Jassim's house and they brought out all the Albu-Fahad guys, and Sattar came. [55:50] All the Albu-Fahads sat all around, and the Albu Beds [sp?] came. That was a really big meeting that Charlton had done. That kind of bridged the gap. Charlton had like 2,000 policemen when he came. He did a fantastic job. I am so happy Charlton came, because he just took what MacFarland had and went with it. He did a ton of good. They did go street by street, but it wasn't the same as when we were there with MacFarland. We were working with nothing! And we were building a police force to 2,000. He did a lot of good things to move it all the way east, and he kept the city safe for a freaking year! For a year there were hardly any incidents. And what he did with the USAID and the rest of them to build all these stations; see, they were doing everything at the expense of the Provincial Council. They didn't coordinate much with the Provincial Council. They didn't seem to get along. But Charlton would do all of his projects under \$50,000.00 so that he could approve them and they wouldn't have to go to the MEF for approval.

Knarr: All CERP [commander's emergency response funds]?

Jensen: All CERP.

Knarr: The video and some of the pictures of the first meeting that you had with Sattar that Amy Foresight took, and then the picture of the meeting with the Albu-Fahad, would really be helpful because capturing that event was a big step.

Jensen: Yeah, yeah, it was huge!

Knarr: We're putting this together in multi-media. We've done it with Mazar-e Sharif. We did some of it with Fallujah, and now this is the next one that we're going to do. So it's for JPME [Joint Professional Military Education]. What I'll also do is I will send you a copy of the transcript of this interview. Make whatever changes you wish, we just want to make sure it is accurate.

Jensen: Ok.

Knarr: And we'll send you any clips that we used of this, ok?

Jensen: Good. And I'll give you that, and I'll give you Amy Foresight's contact information, because she still has a ton of material.

Knarr: Thank you.

Subject: Interview with Colonel Tony Deane, former Commander, 1-35 Armor “Task Force Conqueror,” in Ramadi, May to November 2006

Colonel Tony Deane, commanded Task Force (TF) 1-35 Armor, also known as “Task Force Conqueror,” in Ramadi, from May to November 2006.

TF Conqueror deployed from home-station in Germany to Camp Buehring, Kuwait as part of the CENTCOM theater reserve, also known as the Call Forward Force. In May they received orders to deploy to Ramadi as part of the 1st Brigade Combat Team (1st BCT), 1st Armored Division (1AD) also known as the Ready First Combat Team (RFCT), commanded by Colonel Sean MacFarland. At the time, the RFCT was in Tal Afar, Iraq. TF Conqueror and the RFCT would link up in Ramadi in May.

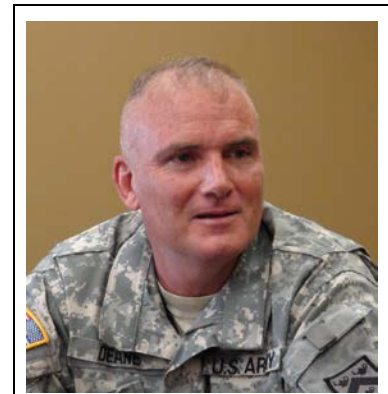

COL Deane, former commander, 1-35 Armor Battalion in Ramadi

Although only in Iraq for a short period, this unit would start the clear, hold, build process south and west of Ramadi and conduct the initial engagements with Sheikh Sattar Al-Rishawi that would be known as the Sahawa – the Awakening.

COL Deane was interviewed at his office at the Battle Command Training Program (BCTP), Fort Leavenworth, Kansas on 12 October 2010.

Colonel Tony Deane: My name is Colonel Tony Deane. I was commander of the 1st Battalion, 35th Armor (TF 1-35), Task Force Conqueror, in Ramadi, Iraq from late May 2006 to the start of November, 2006. Prior to that we were the CENTCOM Call Forward Force where we spent six months in Kuwait preparing to move. We were supposed to be the over-the-horizon force for trouble anywhere in Iraq or in Afghanistan for that matter. The Brigade’s planning priority was for Iraq, and my Task Force’s priority was for Ramadi.

During the time in Kuwait we had Charlie Company, 1-35AR, a tank company, Alpha and Bravo Company 2-6 Infantry, and Charlie Company, 40th Engineers that were assigned to my Task Force as well as my HHC (Headquarters and Headquarters Company). I took command in June of 2005, and so from the time I took command, we had about five months before we actually deployed. Before that I had three years in a NATO assignment where I deployed to

Kosovo, and I worked with the Mediterranean Dialogue Program, which included the North African [Levant] Countries. Between living in Naples and working with the North Africans, I think this really helped me to understand the mindset of the Arabs and really facilitated the cultural understanding. Before that I was in NTC [National Training Center] where I was in the OPFOR (Opposing Forces). I was the S3, 2nd Squadron, 11th ACR [Armored Cavalry Regiment]. I was the Deputy G3 and was the SGS [Secretary General Staff]. Before that I was on BCTP, [Battle Command Training Program] and before that I was a National Guard advisor. Before that I was a Veteran of Desert Storm/Desert Shield, 24th Infantry Division. So, and then before that I was in Germany as a Lieutenant in the 1st Infantry Division.

When I took command, the training glide path was already set. I took command on the 7th of June. From there we went two weeks block leave. We had about two weeks back in Garrison, and then we went forward to something that was called Iron Warrior Gunnery, which was shooting non-standard tables for the non-combat vehicle crews. So it was cooks and mechanics shooting off the side of vehicles. I think a lot of that was a lesson learned from OIF-1 [Operation Iraqi Freedom] when we had thin-skinned vehicles, but it didn't really apply to what we were doing. Then we went to Hohenfels for our three week MRE [Mission Readiness Exercise]. The MRE really was kind of a tough go for the Task Force. We did very well, but the Brigade Headquarters had a lot of trouble (2nd Brigade, 1st Armor Division.) It was my parent brigade, and more importantly, the CTC [Combat Training Center) had not caught up with the operational environment in Iraq at that time. Colonel Vandal, now Brigadier General Thomas Vandal, was on his first rotation as COG. He implemented a lot of fixes and actually turned Joint Multi-National Readiness Center [JMRC] around and did a fantastic job. When we went through the MRE, JMRC didn't have the IED [Improvised Explosive Device] threat. We did that and went immediately to Grafenwoehr for Gunnery. I had a lot of new crews. We talked about units going back or even going back to the same place. The guide-on may go, but the soldiers in that unit are all new. [4:31]

So, we didn't know for sure what our mission was going to be really until we got to Kuwait. At that point, the decision was made to have 14 brigades in Iraq and then one back in Kuwait that could be brought forward. We got there 15th of November. Initially, my task force was supposed to go to Hit, and we were actually told we were going to go I think three times. First they had a Marine unit in there. Then they brought in a MEU for six weeks. For strategic and political reasons, I guess, they didn't want to bring out the Call Forward Force. The final decision was made to move TF 1-36 Infantry [commanded by LTC Thomas Graves] out of the Ready First.

The other problem was that there wasn't a clear mission. There was a lot of talk of even us going back to Garrison by the senior leadership in Germany. They would come down and tell the families, "We don't know anything certain, but by February, we'll probably start rotating units back." And the brigade was working on a plan to redeploy people back to Germany and just keep one battalion forward. That changed shortly after the Mosque [Askari Mosque] in Samarra blew up. My Task Force was actually on the HETTs [Heavy Equipment Truck Transport] ready to deploy. The decision was made by the Brigade Commander to take us off and put in TF 2-6 Infantry. Task Force 2-6 went up to Baghdad at the end of March, so we were still in Kuwait. April passed, and we weren't called forward. At the start of May, there was talk of bringing the entire brigade up to Ramadi and of doing a clearing operation. That never came to pass, and we were convinced at that point that we were not going to get into the fight. But we continued to train. We built a training range at Kuwait. We actually did a lot of collective training down there, which paid dividends when we were finally called about the 20th of May to go forward.

At the stationing area in Kuwait, there really weren't the facilities for a brigade to train, so we had to do everything from scratch. The brigade commander and myself had a bit of different philosophy on what we should be training on. The brigade didn't resource any brigade collective training. The only brigade training that they put on was an EIB. To this day, I'm not sure why we were focusing on individual skills when we had the opportunity to do collective training. Once the EIB was over in March, I took my Charlie 40th Engineers and we built a range out in the Udari Complex from scratch. SOB [straight obstacle blade] lifters, but we safed it out. It was 1800 meters wide, 4000 meters long. At the end of it was a range four complex. It was a really good range complex that we built; unfortunately we inadvertently tore the thing up. It allowed us to do both traditional tank table 12 platoon battle runs, but we did it with a mix of tanks, HMMWVs, and Bradleys. So there would be one section of tanks, one section of HMMWVs, and one section of Bradleys. The platoon leader had to do his fire control, but then, as you entered the MOUT [Military Operations in Urban Terrain] site they actually did a raid mission where he had to control forces on the ground and his maneuver. We tried to make it as realistic as possible.

At the start of March, before we entered this training phase, I had the opportunity to go up to Ramadi. I went with 1st Battalion, 506th Infantry Regiment (1-506), commanded by Lieutenant Colonel Ron Clark. The reports that we were getting out of Iraq didn't really match with the absolute violence that we saw in Ramadi. [09:54] So, when we went back, we really upped the tempo of the training. We also focused on medical training. So, when

someone got wounded, we'd assess a casualty in the shoot house. Instead of just having them Evac'd [evacuated], we actually made them Evac them with an IV in. We did as much as we could to get everyone trained medically, which paid dividends later on.

When we were alerted to go to Ramadi we received the remainder of the equipment. We had very little equipment to train on; especially up-armored HMMWVs, up-armored HEMTT [Heavy Expanded Mobility Tactical Truck]. And a lot of that was for just getting guys licensed on the equipment. We did get to do the Platoon Live Fires with up-armored HMMWVs, so they had a small training stock, but the Soldier didn't have his vehicle that he was going to fight off of like the tank crews had the tanks that they were going to be fighting from. So, we got alerted. We got pushed a large bunch of equipment some of which we only received a day of training on. But there's big difference between going to the rifle range and actually being a good shot. That's what we had with the uparmored HMMWVs and especially with the radios.

When we got to Ramadi, we were taking over for the 1st Battalion, 172nd Armor [1-172] from the Vermont National Guard, which was part of the 2nd brigade of the 28th Infantry Division out of Pennsylvania. Those guys were there for a year. They had a hard, hard fight on their hands. The 2/28th Brigade took, I think, 120 some casualties, and a lot of wounded, too. The Battalion was responsible for an enormous area. They had Tam'eem, Zangora, Five Kilo, and everything out to the west. They actually had responsibility all the way down almost to TQ [Taqaddum] to keep that LOC [lines of communication] open on Route Rhode Island. Then they also had the area that Task Force 1-6 ended up taking over. So, we brought two battalion headquarters in to replace one unit, although the number of soldiers remained about the same – the 1-172 had an enormous battalion. The good news was now you split the problem set, so you had two battalion commanders and two battalion staffs working on that same area. I think it allowed us to focus our forces. When we got there, we also had a Marine MiTT [Military Transition Team] led by Lieutenant Colonel Kris Stillings, USMC. By the time we got there, Kris' men had already lost two guys off the initial ten man team due to a VBIED [Vehicle Born Improvised Explosive Device] on like the 1st of May. Colonel Mark Lovejoy, USA, Commander, TF 1-172 was really very forward thinking. He had given ten non-commissioned officers to augment the MiTT team, which allowed the officers to work with the staff and then the NCOs could go out and go on patrol. Some of their officers did, too. They went out quite a bit.

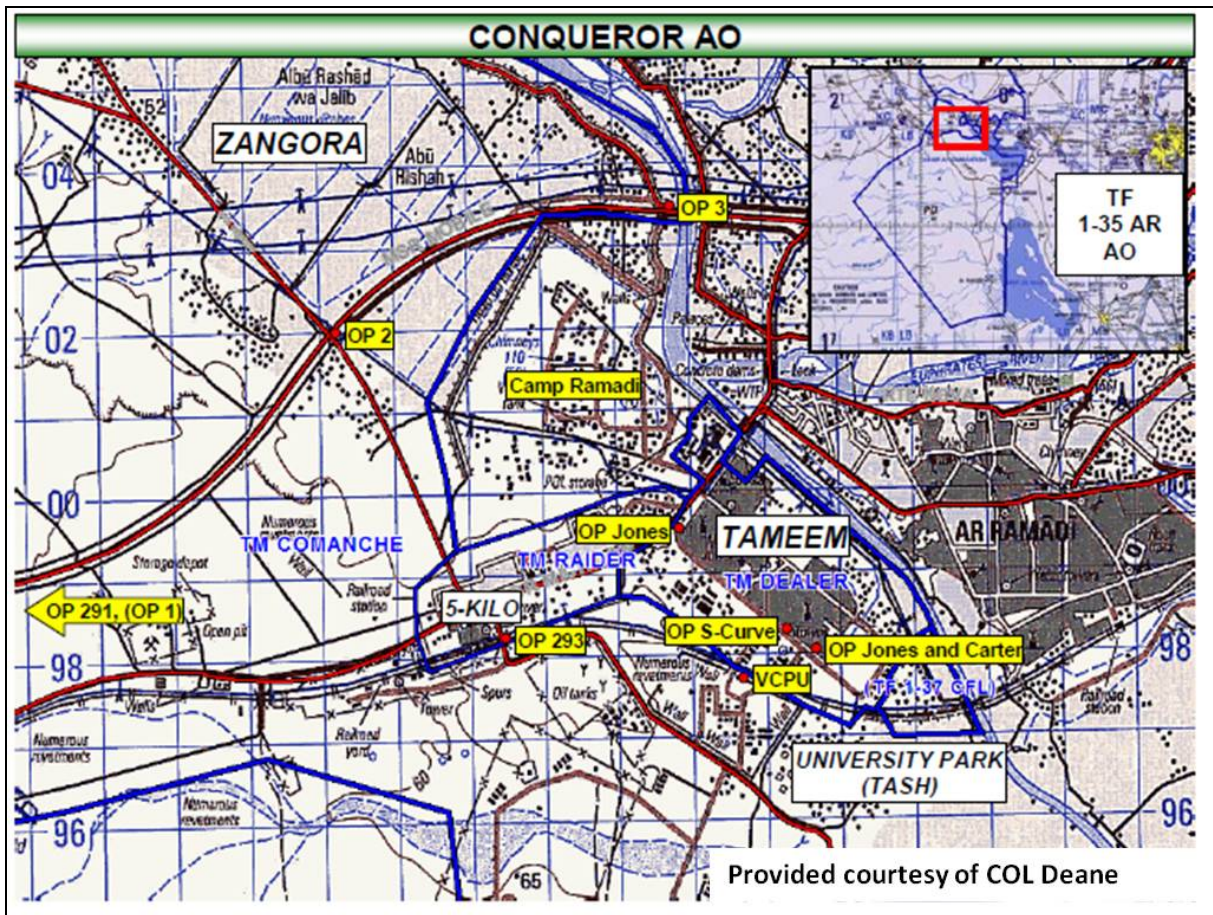

Figure 1. TF 1-35 Armor (TF Conqueror) Area of Operations

The Marine MiTT Team was a tremendous group of Americans and that team was fantastic. The extra personnel gave them the latitude to both train the Iraqi Army and protect themselves and man the checkpoints. The initial set that we took over had six or seven static checkpoints that we had to man 24 hours a day in order to keep Routes Mobile and Michigan open. Then we actually had one all the way out on where Rhode Island and Mobile met. On top of that, we had three checkpoints in the city of Tam'eem where we needed those just to have mobility. So we'd have two tanks or two Bradley's parked at the end of a road looking at each other, and they [the enemy] would still manage to get IEDs in on those roads. But usually they were small ones dropped out of a bottom of a car. We had a guy push one out with a stick one day. If you didn't have actual eyes on that road 24 hours a day, you could expect that you

would get an IED on it. If you had vehicles on it, there was probably about a 10-15% chance of it. As we took over, there was a big sand storm, so we were late getting our soldiers in. The leaders got in on the first lift, and then we had about a three day back log after that. [15:43]

Knarr: Was this 7 June?

Deane: Yeah, well no. It was prior to 7 June. There was a sand storm on the 29th/30th of May, and so as we started taking sector, it was very hurried. Mark did a good job; he gave us everything. He was very, very open. His guys did a good job, but they were more focused on keeping the lines open. The big difference, I think, in the battalion was Colonel MacFarland was there, and he was there to win. The overall feeling to include from the MEF [Marine Expeditionary Force], I thought, was that we weren't losing there, but we certainly weren't winning. Colonel MacFarland brought in a way to win. He said, "We're going to push in the city. We're going to take back land that we haven't had. We're going to build small combat outposts and we're going to get down and live with the people," which now is common sense, but this was a year prior to FM 3-24 ever coming out. This was all, learn as you were doing. learn as you go.

Knarr: Did you get that idea from him? What I mean is, did he come down with that idea or was it something that kind of made sense to you?

Deane: It was Colonel MacFarland's idea. I'll be honest with you. Initially I was a bit skeptical. Initially I was supposed to be the main effort, and we were going to try and seal the southern part of the city. We were going to build combat outposts starting in the South and west of town, starting near Al Anbar University and then into Tam'eem, get a ring around the city, and then push 1-37 in. Pushing out in a small outpost kind of made sense, and we said, "Ok we'll do it." After Zarqawi was killed, which was I think the 7th of June, before the Brigade RIP [Relief in Place]/TOA [Transfer of Authority], the decision was made for us to give up three of our companies. Let me go back. Initially my set when we got to Ramadi was HHC 1-35, Charlie Company 1-35, Bravo Company 2-6, all of which had trained with me. Charlie 40th had trained with me in Kuwait. We got Charlie Company 1-37 and Charlie Company 1-6, which was actually part of Task Force 1-6.

I never really did quite understand why we had all the Charlie Companies, but we did. We gave up Alpha Company 1-6 to Task Force 1-6. The plan was to do what we had to do for about three, four weeks, and then we would give up three of the companies. They would then go to 1-37, who really at that time only had one company and their HHC, and they were going to push into the city.

When Zarqawi was killed, the decision was made to push straight into the city instead of sealing the outside of town. When Zarqawi was killed, we were forced to change everything. We got the word, “Hey you’re giving up three companies,” so at that point we went into an economy-of-force role with my Headquarters Company, my Charlie 1-35 was actually a Tank Company Headquarters with a tank platoon, and I gave them my scout and mortar platoon mainly because they needed the combat power. And the HHC really isn’t suited to lead combat operations. [20:19] Then I kept one platoon of engineers. Lieutenant Toby Watson, the Task Force Engineer, ultimately ended up winning the Wolverine Award for the Army based on what he did there. That platoon moved mountains for us. It was the entire Bravo Company plus one of the tank platoons out of Charlie 1-35. And that was it.

So, when it came to building COPs, I was very hesitant because of the requirements to secure the COP. I didn’t think I could project combat power, and I thought I’d get fixed. I did not realize early on that true security comes from getting down in with the people. So, we were there and we had a very large region. A lot of it was check pointed, and so really I had about an infantry squad sized unit that I could really go out and conduct operations with that wasn’t set on a checkpoint. In order to generate combat power what we did a lot of times was put guys on a 10 or 12 hour shift in order to generate combat power. We’d say, “Hey, you’ve got four hours. You need to do this take down or you need to do this water drop.” Company commanders also ended up doing a lot of missions themselves just because we didn’t have much combat power. Lieutenant Colonel Kris Stillings from the MiTT came to me because I was reluctant to give him ten men because I was running out of people. He said to me, “Hey, if you give me ten guys, I can give you 300,” which seemed like a pretty good deal. So, we were forced into using the Iraqi Army, because we just didn’t have the combat power to do what we needed to do.

Bart: The Iraqi Army or were they Iraqi Police?

Deane: The Iraqi Army. To this day, I’m a little unsure of what the command relationship was, but the 1st Battalion, 1st Brigade, 7th Iraqi Army [1/1/7 IA] worked for me. They didn’t have a Brigade Headquarters at that point, because they built the battalions and then the brigades and then the divisions. I initially looked at the 1/1/7 IA Commander like one of my companies, but then, as I started treating him more like a peer and gave him a seat at the table, I figured out we got a lot more out of him once we started empowering him. So, I had the 1/1/7 IA. I also had one of the two operational police stations that was in all of Ramadi, which was in the town Five Kilo, the Al Horea Police station. It was about a kilometer from Camp Ramadi. [23:52]

Our initial set was along Route Michigan/Route Mobile checkpoints, down in Tam'eem a series of checkpoints, and then one Squad 24 hours with limited operational capability. The IA held the town Five Kilo. It held its own battle space. It was like that when we got there. And the Al Horea Police station which was up and running, but they really weren't getting a lot done. We didn't realize for a while the amount of intimidation that those guys were being subjected to. Most of them were from a tribe that was across the Euphrates in the TF 1-6 sector. They would get stopped by Al Qaeda on the way home and have to deny that they were policemen. Every once in a while someone would figure out that they were a policeman and kill them. Things were just pretty bleak at that point. Like I said, there wasn't really a way to win when we got there.

The other thing that we didn't realize at the time because it was an operational secret was that part of the Call Forward Force was coming forward. It was widely, widely publicized in the Arab media. The first time I met Ahmed Albu-Risha, Mark Lovejoy introduced me to him. The entire Albu-Risha family had been working with the Coalition really since the invasion. Ahmed said, "Ah, you're part of the Call Forward Force from Kuwait." I said, "Ahhh." I tried to mumble my way through it. He turned on the TV we saw the 1st Armored Division Patch and a picture of Kuwait on the news. [25:55]

So, we thought we were just going in and sitting in a sector like every other unit. Al Qaeda thought that a Fallujah-type operation was going on. It's been said quite a bit that the guidance that Colonel MacFarland got was "Take back Ramadi. Don't make it like Fallujah." That was all he really got out of the Marines. So, they thought that there was going to be a large assault. So AQI, in anticipation of this expected assault, had actually pre-chambered the entire road, particularly those areas 1-172 had not locked down. So there were a lot of massive IEDs that were buried that we ran into.

We decided that we were going to take back the city. We were going to push into town. We were going to figure out what was going on. So, as we went to left seat ride, we started taking charge and had guys up 24 hours. I started pushing them out. We were hit with an IED at ECP [Entry Check Point] 3, which was an IA checkpoint that was at the very southern end of Tam'eem overlooking the railroad bridge that went into Ramadi. It was right next to Al Anbar University. It was hit with a massive IED on the 4th of June, which devastated the checkpoint. 1-37 took over the checkpoint, because they really didn't have a mission right then, and we were kind of reeling from what we had. Then that night, we took our first casualty. I think it was 12 x 152mm rounds, deep buried. They destroyed his HMMV, killed one and wounded four, all of which went to Walter Reed. Then three days later, right before we took over,

Lieutenant Scott Love and Private First Class David Crombie were killed in another massive IED. I think it was 15 or 16, 152mm rounds. So, at the end of RIP, we had one ECP destroyed by a VBIED. From that, we had a couple casualties. Two Iraqi Officers were killed, and six or seven Iraqis were wounded. It was a complex attack and the XO in my Engineer Company, got shot during that battle. We had an ECP destroyed in two massive IED strikes, which I think killed three and maybe eight were sent to Walter Reed by the end of that. It was very violent.

The other mission that 1-172 had was to protect the police recruiting site, which was in a place called the Glass Factory. It abuts next to Camp Ramadi. It took a brigade operation to do this recruiting mission. [30:09] It took snipers, pushing in the city, and sealing off checkpoints, actually right near where Lieutenant Love was killed. It would take us the entire Task Force to conduct this mission and then to push in. Then we'd have to go back and pretty much clear our way completely back into town. Once you took your eyes off the routes, you could expect that you'd get IED'd. So, we just didn't have the combat power to do it, so we were kind of looking for a way around it. I had met Ahmed Abu-Risha when we RIP'd. He'd been a longtime supporter of the Coalition. We went over to his house, and there was a plaque or a gift from every unit that had been there before. Mark said, "Hey, he's a pretty trustworthy guy." Like I said, he'd been working with the Coalition for a while. These recruiting drives had been going on since January 2005, and they really were only bringing about 10-15 guys a day per operation. So when you looked at the time and effort required and then the results, it just didn't make sense.

So, we went over and talked to Ahmed, and built the relationship over a few visits to his house. One day I went over there. They explained to me the problems with recruiting events. Guys would go. They'd go home and get intimidated. They had trouble getting guys in the police. I said, "Well Ahmed, if you can get your guys to join the police, we'll do the recruiting drive out here in the tribal area. Then we'll ship them out the same day, so they won't get intimidated."

When we went back and sold it to the Marines, we said, "It only forces them to be brave once." Ahmed jumped at that, and he offered up his house. I never looked at Ahmed as a sheikh. I looked at him as a local leader much like a union boss or an alderman. I just looked at him as a leader in the community. I said, "Look, if you can get the guys in your tribe to get on board, we'll do this." He actually reached out to a couple of the other tribes, and he offered up his house. I said, "Hey, this is pretty good deal." I went back and talked to the guys at the brigade. Lieutenant Colonel Jim Lechner, who was the DCO [Deputy Commanding Officer],

got on board pretty quickly. Lechner was in charge of the Iraqi Security Forces. He saw that we were on to something here. He went to the MEF and there was a tremendous amount of pushback. "That's not what the policy is. We have a system. You can't change the system." There was a lot of bureaucracy from guys that I'd never met or had never seen, because they certainly didn't come down to my area. But Jim Lechner is really the guy to get things done. Jim [fought] a battle with the Marines, and finally they relented. [34:12]

So, we had the first recruiting drive on the 4th of July, 2006. We went out there and secured the site with my Charlie Company (C/1-35AR). We secured the area around Ahmed's house, because we were worried about suicide bombers. It actually got mortared from a mortar team that was shooting from across the river in 1-6 IN's sector. I think the AQ guys were pretty smart. They'd shoot from one battalion's sector into the other, because they knew that there were always coordination problems. So they shot from 1-6 IN's sector way. I showed up right after the house got mortared. I talked to Ahmed, and his family was there. Sattar was there. His sons were around, and the women were in the back. I said, "Hey, I got it. We'll stop. We didn't mean to put your family at risk." They both said, "No, absolutely not! We're going to see this thing through!" To me that did a lot to put their stock [credibility] up in my mind. [35.41] It's one thing to risk your life; it's another thing to risk your family's life. Really, towards the end, I started looking at these guys as Iraqi Patriots; I mean much like the Founding Fathers.

So, I think that initially they promised us 400, 300, 200 people. We ended up getting 80, but the Arabs tend to talk in grand terms, the Mother of All Battles with Saddam. On the books someone told me there was 300 police in Ramadi at that time. To tell you the truth, I never saw more than 20 in one place. So, to me it was a big success. I mean we damn near doubled the size of the Police Force in one day. We decided, "Ok. Every month we'll do it out there." We actually did them at Ahmed's house. I think part of the reason that the Albu-Risha kind of rose to power in the tribal scheme is because in the tribal hierarchy, Ahmed was at best sheik middle management. I mean, he was the sheikh of his tribe, but it wasn't a very big tribe, but he had the 'in' to the Americans. I think anyone who wanted to talk to the Americans would talk to him, because he could talk to me.

Ahmed left in the middle of August, and they told me he was going on vacation. I never saw him again, so I don't know where he went. I don't know what he was doing, but he left in August and didn't come back. Sattar, who I'd met before, was Ahmed's younger brother. Word on the street was "He's got a business. He might be a little bit shady. He certainly wasn't the brains of the operation." But Sattar was there, and Sattar had a lot of charisma.

When he walked in the room, everybody looked at him. He was just a real, real forceful guy. He was always immaculately dressed. His robes were never dirty. He always looked immaculate, and he carried chrome plated, ivory handled, Colt 45 Sesquicentennial Issue with the state of Texas on it. It was really a sight to behold.

My battalion saw the key as, “If we can get them to join the police, then we’re not arming the tribes, because actually now they’re in the police and we are arming them as policemen.”¹ Additionally, they get some training; they take an oath; they’re getting paid by the government, which is bringing economic benefit to the area. Since they are getting paid by the government, they now have a vested interest in the government succeeding.” So I really saw our lines of operations hitting on three or four of the key things we were trying to get done. So, whenever I had any free time, I’d go over and I’d talked to Sattar and sometimes to Ahmed, [End of file 1] but Ahmed left as I really started to gain this understanding of the situation. I spent a lot of time with Sattar. We’d sit over there and a lot of it was work. Every once in a while he’d pass us some information about where some bad guys were. He’d give us context to the area. Sometimes we’d just talk about world affairs.

The guy loved to talk about democracy. [2:39]² He really was a big believer in giving people a chance. If you turn the clock back from the time of OEF to Desert Storm, that was 17 years of real oppression in Iraq. Saddam skimmed off the top any money that came into Iraq for himself. Then he’d blame the Americans for any problems that they were having. They indoctrinated the kids in the schools [against the Americans]. I think that was a big surprise for us just because in Desert Storm everybody seemed to like the Americans, and they were kind of glad we were there. I think Saddam had time to brainwash the population to hate the Americans. The abuses of his regime and not taking care of his people, he blamed on the Americans, which was an easy scape goat. Saddam’s reign was really 40 years of terror. So, Sattar was able to travel around, particularly in the Middle East, because he came from a pretty wealthy family. He gained an appreciation for democracy, and he thought it was a pretty good idea. Then talking to him, I’d always say to him, “Why can’t this be like Germany and Japan?” At the time neither Nation were supporters of war. I said, “You know, I live in Germany, and we pay a lot of money to the Germans. They’ve been making dollars hand over

¹ The battalion was accused of arming the tribes, the point is that since they joined the police before they were armed, that accusation was not true.

² There is two minutes of repeat in audio file 2 from audio file 1.

fist off the US for the past 50 years. We're certainly not dictating to them and at some level they are fair weather friends, because they're not supporting us in this war. They're autonomists. And you know, both countries are making a lot of money off each other." I kind of talked to the economic aspects of it, but also they really saw a stable, wealthy society come out of fighting the Americans. Actually, in his Awakening speech, Sattar took it a step further. He said, "Why can't this be like Germany and Japan?" He went on to talk about how Germany was then. He said, "Look who beat the Americans, Vietnam. If you want to be poor, go move to Vietnam. If you want to be rich stay here and side with the Americans." This was a little further than I wanted to go, but he certainly connected the dots. [5:26]

After being there for a couple of months, it was apparent that it was absolutely violent and there was absolutely no governance. The governor was named Mamoun. He was protected. He worked at the Government Center, and a Marine company was assigned to protect him. He was the elected Governor, and we had to keep the guy alive. But, he was the only guy coming to work at the Government Center, because everyone else was getting killed. The Government Center would get assaulted with these complex attacks consisting of mortars and 100 guys shooting two or three times a week. That's just the way it was. There was really no governance, except for the governance that the Americans provided. And there really wasn't a way to get ahead on that front either, because a lot of the Provincial Council had either left for Jordan or were living in Baghdad. I found out later that the Anbar Provincial Governing Council was meeting in Baghdad.

Knarr: That's what I heard.

Deane: How is that helpful? So then I started talking to Sattar. The police recruitment was working, and more and more sheikhs were starting to come see him. He was becoming more of a central figure. I said, "Sattar, you need to get your sheikh buddies to tell whoever their guys are that are a part of the government to start showing back up to work." The security situation didn't really lend itself to that. Both security and governance needs to be moving along. I kept saying, "Hey we need to do something about the governance. You need to get behind it." What I didn't realize at the time was the tribes all thought Mamoun was AQ. They didn't think he was 1920's or part of the Mujahedeen, but that he was straight up AQ. That's what they thought, so they didn't support him. One of the things they always talk about was Anbar receiving 300 hundred million dollars from the Iraqi Government, which actually probably came from us. They never saw any improvement in Anbar, and they thought Mamoun had stolen all this money. [8:15] Well, there was absolutely no system in place to spend that money. There were no bureaucrats, there was nobody coming to work, and there

was nobody at the DMV [Department of the Motor Vehicle], so they all hated Mamoun. When you read the Awakening Council's paper, and we'll talk about that in a minute, I saw it as a recall election, because the Sunnis did not vote at all in the first election.³ In 2005 they did not vote very much. Statistically, it was a lot higher than the previous one, but still as a percent of the population, it was still pretty low. And a lot of them just boycotted the elections, because they didn't have much faith in the election system. As you got further into 2005, they figured out that the election wasn't rigged, and now they were stuck with Mamoun. They were trying to figure out a way to change that. I think they really wanted to get involved in the process and in governance and democracy. They saw the Awakening Council as a way that they could do that and change things.

We continued to get police in July and August. I think we had three recruitment drives in July and August, and each one of them brought in a couple hundred guys, so we really had doubled the police force. In September, the numbers were low and we went to them and said, "Hey what happened?" The problem was by that point about half of the available men in this core set of tribes were in police training, and they needed the other half to protect their families. They said, "We just can't do it right now. When we get these other guys back, we'll send some more." I said, "Ok," and it just continued to build. Then after the Awakening started, the numbers just went through the roof. [10:32]

Knarr: You call that donor...

Deane: Yeah, donor fatigue. They just couldn't pay anymore. That was actually Colonel MacFarland's phrase. So, I went on my mid-tour leave about mid-August. I went over to the Albu-Risha compound with Major Chuck Bergman, my XO. I told Sattar, "Chuck, my number two, is going to be in charge for a couple weeks." Chuck had been out there and met him a couple of times, but you've really got to understand what the relationship is and make sure that Chuck felt comfortable talking to him. This was prior to the Awakening and it was becoming apparent that the Albu-Risha were the guys to get in contact with the other sheikhs. Some of these sheikhs were outside of our AO. Sattar was gaining importance, and we wanted to make sure that something crazy didn't happen.

While we were there, there were four or five other sheikhs present [Figure 2]. One of the sheikhs was Sheikh Ali Albu-Jassim [Sheikh Khaled A'rak Ethami Al-A'layawi], who

³ Colonel Deane was originally misquoted in some accounts as saying this was a coup, but he really characterized it as a recall election.

ultimately ended up getting beheaded. AQI held his body, which a lot of people equate as being the catalyst for the Awakening taking over.



Figure 2. 20 July 2006 at Sheikh Stattar’s house. LTC Deane in the middle, Sheikh Sattar on the left, Sheikh Khalid Ali Abu-Jassim 3rd from the left. Photo courtesy of COL Deane

I think it was already forming before he was killed. I think Sattar and the rest of the sheikhs used that as a rally point to really highlight the abuse of Al Qaeda. I was talking to them and it was always the same when you talk about the sheikhs. They would say that a bad man in a black Opal drove by their house last night. “Why can’t you catch him? Why can’t you protect us? You put a man on the moon? Why can’t you figure out who these guys are?” The problem was that they all knew who the bad guys were. They all knew! It was just like in America, the people who live there know who the guys are in the mafia or they knew who the hard core gang members in the inner city were. So, I kind of snapped at him a little bit. I said, “Hey look, all you guys look the same.” My translator Dragon, who’s great, fantastic, and was also

my cultural advisor, had been there for a couple years. He's an older gentleman. He looked at me and said, "I'm not telling him that." I said, "Tell him that word for word." So he told him that word for word, and they all got mad. I told them, I said, "Hey, look, if you were back in Nebraska, we all wear cowboy boots, cowboy hats, blue jeans, plaid shirts, and big belt buckles; we'd all look the same to you. Just like on the westerns. You have trouble figuring out who is who in the old movies." They all watch a lot of movies. They were still grumbling about it, and I said, "I can't do this by myself. I need you guys. You guys say you want to fight AQ. You get your boys in the police, and I will train you, but" I said, "You guys all look the same. I can't figure it out." Dragon translated that and there was a bunch of yelling and shouting back and forth, but in the end we got them to understand that really the solution comes from them. [14:13]

So, we left that day. A couple of days later, Khalid Ali Albu-Jassim went from there to talk to the tribe to his north. I can't remember their name right now, but they were truly kind of knuckleheads. It was over in 1-6 IN s sector, and he ended up getting beheaded. So, when I came back off of leave, they were like, "Hey, they got him. They've got his body." It was like the day I got back, and I was like, "What are you talking about?"

Knarr: When was that?

Deane: The end of August. The Sheiks wanted to do a joint operation with us and go get the body back. Since it wasn't my sector, so, by the time I made the right contacts, they just went up there and got him themselves and metered out a little tribal justice. [15:16]

So we were back for about a week when I was out driving around with Major Dave Raugh, my S3. I said, "Let's stop in and see Sattar," because there were still some hard feelings over this sheikh getting killed. I went in there and the room was just packed, absolutely packed full of sheikhs even a couple of Arabs in business suits. That's when Sattar said to me, "We are going to fight. We are going to join you and fight Al Qaeda." I said, "Ok. Good!" And he said, "And here is our document," and he handed me some documents. I don't think I could have written it better myself. It was rule of law, and it was economic progress. It was really what they wanted to see done.

The only problem was they wanted Mamoun gone. So my translator said, "Hey, you know this is going to be a problem." I said, "Sattar I'm not sure you can just take over the government." And he said, "Yes, it's in the constitution." Literally, I mean, he yelled and it goes down the line, and two Iraqis in suits come out and they were constitutional lawyers. They had a copy of the Iraqi Constitution, written in Arabic, and they're showing me the line

in their Constitution where this Awakening Council is authorized. I was thinking to myself, there are Constitutional scholars in America, and I am certainly not one of those let alone an Iraqi Constitution scholar. I said, "Well ok. I hear you guys. We want you on the team. This is great, but I just don't see getting rid of Mamoun. He's elected. He's the governor. It is what it is. All this other stuff, I've got to take this to my bosses, because this is big news. This last [point] is going to be a sticking point."

Knarr: These were the eleven points?

Deane: Yes, these are the eleven points. [See attachment 1]

Knarr: They were given to you on the 9th of September, is that right?

Deane: No, it was like on the 4th or 5th of September, because then I said, "You've got to meet my boss." I had to get a little breathing room. So, I went in and I saw Colonel MacFarland, and I said, "Sir, good news, bad news. Good news is the sheikhs are on the team. Bad news is they want to get rid of Mamoun." I mean things like this had happened before, but Colonel MacFarland saw that this was an opportunity. I said, "Hey look, they want to meet you. You know, these are the guys that are putting people in the police." It didn't take any convincing with Colonel MacFarland. He was more skeptical than I was, but he certainly recognized the opportunity. He went up, and he called the Marines and told the MEF leadership. There was a lot of push back. [18:44]

Knarr: What was the push back?

Deane: "Don't get involved with the sheikhs. Mamoun's our man." There had been a few Marines injured and killed protecting Mamoun and he was the elected governor, so, strictly speaking, "He was our guy. He was the U.S.'s guy." But he wasn't getting it done. Now, the most important thing was to get rid of the AQ guys. Going back in time a little bit, when we got there we sat down and we said, "How many people are really fighting this?" You couldn't go outside without getting shot at or getting blown up, but how many guys does that really take in a city of 400,000? And we really figured out in our opinion it was probably like a couple hundred guys that were fighting us day and night. And then there were a lot of people supporting it. We figured out there were hard core AQI guys. These are the guys walking from Yemen to come blow themselves up. You couldn't turn those. Then there was the Mujahedeen. The Mujahedeen was every 18 year old, every Iraqi former military, and every guy who felt they had been wronged by the Americans. Well, we figured out that if we could split the Mujahedeen from AQ, then we could defeat AQ and worry about the Mujahedeen. And I used to tell my guys, "If I was an 18 year old Iraqi, I'd be a Mujahedeen. [Like] the

movie Red Dawn. It's Iraqi Red Dawn; "them boys are pissed!" And what do we do? We're driving around town, shooting at them and shooting up their houses. If we can figure out how to split the Mujahedeen out from AQ, then we can win." And so our way to do that was to make it cool to not fight us, but to fight AQ. If we can figure out how to do that, we can win it. [21:32]

And so as the tribes start getting on board, the tribal leaders are saying, "Hey it's no longer cool to fight the Americans; it's time to get rid of these AQ guys." AQ had been abusive. They really played into our hands, and we would make it a point. Every time they blew up a police station or any time they attacked the Iraqis we had an Iraqi on the loud speaker. He was a translator; he was an old Iraqi guy who worked for the Civil Affairs Team. You can tell the age of somebody by their voice. He had a very good voice. He would get on there and he would say, "These guys are killing the sons of Anbar. They're killing the sons of Ramadi. How is this helping you? These are your cousins that were killed." We really made it a point to play up the fact that the AQ guys were really oppressing them.

One of the other things that happened was at Al Anbar University [See figure 1 for location]. We went in there in the end of June. We went because to me that's where the hotbed of the trouble coming out of Tam'eem was. When we went in there, we knew that politically we couldn't hold it. We would just be magnets for IEDs or for suicide bombers. We said, "Hey, we're going to take the university, but we're going to leave an Iraqi presence there. We're not going to hold it, the Iraqis are" We got a MP Company from the 7th IA, which had just stood up. They were in pretty rough shape; they weren't a very good unit when we got them. They had a MiTT team from the Division Level MiTT. Those guys really didn't want to be there either. We went in there. We cleared the school. We found rockets, RPGs, black masks, and sniper weapons. We'd been taking IEDs from the university on Route [Gremlin] which ran to the south. [24:11] We got a couple guys wounded out there. You know, we found the wires leading back into the university. We said, "Ok, they think that they have free reign." 1-172 had gone in there, and there was big political backlash. They took a lot of heat for it, so they kind of left the university alone. I said, "Well, we're going after them."

And so, we went down there, cleared the university, and we left this Iraqi MP Company with an internal Task Force MITT Team complete with Lioness Female Search Teams there. Our point was, "Look, we didn't take it over. The government took it over; the Iraqi Military took it over. It wasn't us." They all knew it was us, because we did the majority of the heavy lifting. In the end, it showed that the Iraqi Government was taking charge of the university. At one point, the university was the hotbed for the 1920's guys, but then the Mujahedeen invited

AQI. The AQI guys just started taking them over, and the university became a hotbed for AQI recruiting and much more violent. [25:25]

So, we took over the university. Then AQ came back, and they started this whisper and night letter campaign. They said, “If you send your children to school, you are a pawn of the Americans, and therefore you will die.” They started a rumor that AQ went in and killed six kids and beheaded them for going to school. They had some American soccer balls or something. We never saw any evidence that this actually happened, but you know rumors are a pretty effective tool. If there was a rumor that a kid had a gun, nobody would send their kids to school in the States. People are no different wherever you live. No one went to school in Ramadi for six, seven months. Then it was really this battle of wills between us and them. The people started figuring out over time: I can’t send my kids to school. I keep getting caught in the crossfire. Some guys planting bombs to kill the Americans outside my house, but it’s just hurting me. Then we gave them an out with the police. It really turned once they held the Awakening Council. Ok, so, back to the present, we set up a meeting between Colonel MacFarland and Sattar, and we went there and the place was full.

Knarr: Was this the 9 September meeting?

Deane: This is the 9 September meeting [Photo at Figure 3]



Figure 3. 9 September 2006 Meeting between COL MacFarland, LTC Deane, Sheikh Sattar and the Ramadi area Sheiks representing the Awakening Council. Photo courtesy of COL Deane

Sattar wanted either me or Colonel MacFarland to come speak at this Awakening meeting. We were going to stand shoulder to shoulder. We told him, “Hey look, we don’t need to be there. This needs to be an Iraqi solution to an Iraqi problem.” And it really emboldened them. They said, “Ok.” Colonel MacFarland met Sattar. Colonel MacFarland recognized that these guys were serious. They were the real deal. We didn’t 100% throw in with them, but we saw that this was a way out of this mess.

Then on the 14 September Sheik meeting, we pulled security on the outside. the brigade sent some helicopters. They flew CAP (Combat Air Patrol) on the meeting. My Battalion increased checkpoints on Mobile and Michigan out in Zangora. It was funny. We drove out there and there’s a guy in a Toyota pick-up with a machine gun on the top and 6x 12 Iraqi flag flying off the back of this thing. Every time, they’d have the Iraqi flag out there. They didn’t have any tribal colors. They were like, “Hey, we are throwing in with the government.” So, the meeting comes off.

The other thing that happened was that the initial group of police was coming back from Jordan. When I first met Ahmed I said, “If you get 500 policemen...” which was an outlandish number at the time. I mean there was no way. I said, “If you get 500 policemen, I’ll build you a police station.” He said, “Ok.” Well, they got 500 policemen, and so then it came down to, “Hey, we need to build a new police station.” I went to Lechner and I said, “Look, we need to build a police station.” The Ready First saw it. They said, “Hey look, things are getting good out in the tribal area. We’ll build on success. We’re fighting into the city.” Jim Lechner and I had a disagreement of when to put guys into the city. I said, “Hey look Jim. They’ll fight for their area. That’s why they want to be in the police. So, let’s get the tribal areas set then we’ll work it out. Then we’ll start putting guys in the city.” A lot of times in the past when they did get a few recruits, they’d take them and try and put them in downtown Ramadi. The [recruits] would stop coming to work. But, you know, strength in numbers and strength in defending your family. So, Jim and I reached an agreement on that. [2nd file ends]



Figure 4. Sheikh Sattar announces the Awakening at his compound, Photo provided courtesy COL Deane

[File 3 starts at 3:44] We were going to build this police station and then it came unglued. MNC-I [Multi-National Corps- Iraq] was calling us. They said, "Why are you doing this? There's a building plan for a police stations. We just can't build police stations willy-nilly" So, we thought we were going to look like we're going back on our promise! We had picked out the place where we wanted to do it, and there was this house that had potential. We told Sattar, "Look, you give us the house, and we'll put the police station there." Meanwhile this whole thing is going on—they can't build it, they can't build, can't build it! So, this poor guy who was a school teacher, I guess, saw me and the Engineering Company come out there measuring stuff. The guys looking around like, "What are you guys doing?" "Nothing," we said.

We had to address the MNC-I and MNF-W concerns with building a police station. Finally we said, "Ok, we won't build a police station." I said, "Can we build a police substation?" They said, "Oh yeah, you can do that." "Ok!" This is all going on while the battle's still raging in town. We're still taking casualties every couple of days. All of this is going on at the same time. [5:31]

So, I took my support platoon and really got a bunch of T-Walls, and T-walled off this house. I had half of a MP Platoon, but I got the Platoon leader from 2nd Brigade, 1st Armored Division, my parent brigade, that was actually sent up with us. The initial platoon leader that was over in 1-6 IN s area, got burned up on a VBIED, which really devastated that platoon. A VBIED hit, and there was a gas tank inside the walls of the other IP station. Something burning landed on the gas tank. As everybody ran out to see what happened with the VBIED, the internal gas tank blew up and five or six of the MPs, got burned up pretty bad. But, the new platoon leader came in, good kid. His name was Stephen Winter. I put Winter, my HHC Commander, CPT John Cornett who had just left command, and this Squad of MPs, out there at this police station. I told him, "John, make this happen." I had a bunch of smart captains, Nick Franklin, Pat Fagan, Sean Frerking, and my S-4. I said, "Hey look, this thing needs to happen. Make it happen!" And I had no idea how to build a police station. These kids knew how to do it! They did it. Most of them were OIF-1 vets. They had built some for the ICDC [Iraqi Civil Defense Corps]. So they got out there and then all of a sudden we started getting uniforms, radios and trucks. Lechner was good about getting stuff.

Then we had one open recruiting there, and we put all these T-Walls around it, so it couldn't get hit. Those [Iraqi] boys were out there. They were pulling security on their own station. We don't know who belongs and who doesn't belong, but these guys are from the neighborhood. They know who's who.

Knarr: Was this Tway?

Deane: This is in Tway. And that thing got hit with probably six VBIEDs in the first three weeks. Then we said, "You know something, this is it. This is it! AQ is scared of this!" I can't remember the date, but right after that one (TWAY IP station) opened AQI finally got one [suicide bomber] in and they blew up the Al Horea Police Station. That night I sent my HHC out there. I called the HHC Commander and the First Sergeant and I said, "Hey look, you get as many guys as you can. You go out there, and you hold this police station." I mean you're talking cooks and clerks. First Sergeant Kerry Dyer and Captain Mike Schoenfeldt went out there and they held that police station. And if we had pulled off, there would have been no one at work the next day. We stayed there. I sat there with the Police Chief who was devastated. He lost two of his guys. He got his office blown up. He ran this police station on a couch in a blown up building for about three weeks until we could finally get in there, get some stuff torn down, and get some more buildings in there. But, the police started taking hold and then it really started to take off. About then is when I left. [9:12]

I guess one aside that I really learned was investing in the Iraqi Army. When I first took over, we went out to checkpoint 293 [location reflected at Figure 1]. I'm out there, and there's literally crap everywhere, human excrement everywhere. I said, "Why is there crap everywhere?" The NCOs in the MiTT Team were like, "Well Sir, you know, they got weak leadership. These boys just take a crap everywhere. They live like animals." I said, "Well, where are they supposed to crap?" And he's like, "I don't know. That's their problem." I was, "No, it's our problem. Where are they supposed to crap?"

So then he started looking around and we had our guys in CONEX [container express] containers, MILVANs that we put in air conditioning. One of them was an office, and one was a sleeping area. It was rough living, but it was nicer than anything in Desert Storm ever was. I look over where the Iraqis are living. They are literally on a bunch of broken cots, and there's a tin roof building where you can see the holes from where the mortars went through. This thing had been hit with three VBIEDs. They got hit with I think four or five VBIEDs by the time I finally left. They had just lost some guys right before I got there. So, I'm looking at this thing and thinking what the heck? Again, I went to my engineers Toby Watson and CPT John Hiltz. I think the Company was with me at that point. I said, "John, get out there and build some CONEXs. Get the CONEXs built, and put air-conditioning in them. Put in some bunks, and put overhead cover on it, so that they have a place that's safe. I thought it looked like the pictures you see of Buchenwald where you know you'd see the poor prisoners in the bed. I never saw Amistad Aristid? but Hiltz said it looked more like the slave ship Amistad.

You'd walk in these things and there'd be these long bunks, and there would be all these Iraqis sleeping in them. But now it was air conditioned, and it was safe. They had a huge AWOL problem, which stopped literally the day we delivered those things. It showed them that we cared about them. It gave them an idea of what right looks like, and they moved out from there. Really, the 1/1/7 IA was down to 40-50% strength because of AWOLs (Absent Without Leave), but once we built those things for them, the AWOL problem stopped pretty much over night.

Stillings, the MiTT team Chief did a good job of leading me to where I needed to go. I told him, "You go down there, and you tell Colonel Mustafa this." And he said, "I'm not. Why don't you tell him?" And honestly, the thought never crossed my mind that my job was to talk to the Iraqi Battalion Commander. I thought my job was to talk to the MiTT Team. I said, "Hey, you're right." And so I went down there.

Then we started figuring things out. We used to have a separate meeting with the IA like a targeting meeting. 1-172 did these, and they were a feel good kind of thing, but then we started bringing them in to our weekly meetings. I had brought the commanders in once a week. I made him sit there. I made him brief what his plan was going to be, what they were going to get done that week, and what they got done the prior week. But, I sat him at the head of the table, at the seat of honor. Whenever I'd make a decision, and whatever there was something to make a decision about, I said "Well, what do you think?" "Oh, yes, yes. Oh, yes, yes," [he said.] I treated him like a peer. I gave him a voice, and then they really started getting after stuff. We took fire from the blue Mosque in Tameem one day, and he actually generated a company-sized force in about 15 minutes, which is remarkable for the Iraqi Army at that time. The mosque had rifles, IEDs, and police vests. It was a hub for the AQ guys there. We actually went in and did a major operation right before we RIP'd in Tam'eem.

Knarr: Dealer? [14:38]

Deane: No this was prior to Dealer. We did a validation exercise. The Iraqi Army had been in sector for a while, and this was one of the points that we rubbed heads against brigade. They [IA] had owned their own battle space for about a year, and they said, "Hey you never did a validation exercise." We responded, "These guys have been in [15:03] combat. They got it!" And brigade said, "No. We need to do this validation exercise."

So, we took them and we put them into Tam'eem, an area in which they really didn't have a presence. I wanted to get the IA in Tam'eem, but I didn't have enough of them, and I thought it would be too violent for them. So, we go into the white apartments. We'd been in the white

apartments probably a hundred times. I probably personally had been through that thing five times. In fact, I had just been there the week before with Bravo Company. We would go through there, and nobody in the community would claim they were in charge. Nobody knew anything. So we go in there with the Iraqis, and all of a sudden these guys [the residents] are bringing out tea. Everybody is slapping Mustafa on the back. They could have made him mayor! So, one guy comes out and he's like, "I'm the Mukhtar." I'm the head guy here. I was a little mad. I said, "Hey, I saw you last week, and you told me you didn't know nothing." And the guy looked at me and spit on the ground. I don't like Americans. So I just left him. I could have argued with him, but in the end, the Iraqis got to figure this out.

The locals started giving up guys to the Iraqis. And I said, "Ok." It became clear that it was time to put a COP into Tam'eem. But I didn't have the forces to really do it. The brigade didn't either, because now we had all these combat outposts. We were starting to run out of combat power. Well, the 1-77 was part of the Dagger Brigade and the Dagger Brigade had the Call Forward Mission, and 1-77, Bear Johnson [Lieutenant Colonel Miciotto Johnson, Commander, Task Force 1-77 Armor], came up. He'd been there for a couple of weeks, because I think they held them in Germany for a little bit. They didn't move immediately in Kuwait. So, I said, "Ok Bear, here's what we're going to do. You get your guys and your combat vehicles and you go lock down all the check points. And we're going to go in the city, and we're going to clear that place out for you." And Bear's like, "What?" This is pre-RIP, pre-anything. I just said, "Get your guys in here." You know, no real left seat, right seat ride, "You just go out there, and you take sector." And nobody had attacked us at the checkpoint the whole time we were there. No one drove an SVIED [Suicide Vehicle Improvised Explosive Device], into a static location, in my sector at least. I said, "You get out there, you lock these things down."

So Bear's guys got out there and locked it down. In that operation I had Alpha Company, 1-35, Bravo 2-6, Charlie 1-35, and then I had like a battalion and a half of Iraqis. I had 1/1/7 IA and half of 2/1/7 IA. And then I had these police from Tway. I said, "Hey look, I need you boys to come on down here." We had a joint US/Iraqi Army/Iraqi Police [operation.] We went in there, and we found a bunch of stuff. We found a place where they made suicide vehicles and a huge cache. Once we went in the city with those guys and we got Dealer, we started figuring out more about this mythical cache in the Palm Grove that we had been looking for for six months. Additionally, the people were giving us information. Once you got in there with the people, then they felt safe to come and tell you. Then we actually did RIP/TOA. Then Bear took over. But, really, the key was getting close to the people, you had to be there

in the neighborhood. General Casey was saying, “You can’t just drive through [the neighborhood], you’ve got to be there.” I didn’t realize that you cannot just walk through a neighborhood either . No, you just HAVE to be there. [20:05]

Knarr: That’s interesting. I am seeing GEN Casey in December. I heard criticism of Casey that he promoted living on the FOBs and not getting out, and it wasn’t until Petraeus got there that people moved in with the population. I am curious what was the word at the Soldier level?

Deane: I don’t know. I mean there was political pressure to reduce footprint in Iraq. There was another theory that a lot of this violence is directed at us, so if we’re not there [it won’t occur]. Out of sight, out of mind. I think that was going on. I think there was a cost involved in being out there in the neighborhoods. The problem I think was that we could have pulled back if there was some governance to stand up, but there wasn’t. What we were able to do in Ramadi, which other people before us hadn’t, was there was always this thought process of, “The Iraqis have to do it themselves.” Well, if they can’t do it themselves, they can’t do it. I always tell people it’s like bench pressing, and we’re spotting them. For the first couple of reps, we were doing trap holds. We were just straight lifting the bar, but they’ve got to have their hands on the bar. Sooner or later they’ll be able to lift the weight. LTC Dan Walrath, Commander, TF 1-6 Infantry had a great quote. He said, “The Iraqis are the bravest where we’re the strongest.” It makes sense, which goes back to the Awakening. The MEF didn’t want to play ball. They just did not want to play ball. Actually, their ADC [Assistant Division Commander] for engagement...

Knarr: Brigadier General David Reist?

Deane: Yeah. Reist came down to the Tway IP Station one day, and we were showing him around. He said, “Hey Sattar’s a criminal. You need to go arrest him.” I said, “I’m not arresting him. You arrest him.” We got into a little shouting match there, which I’m surprised he didn’t lock my heels, but he didn’t. They were convinced that Sattar was a criminal. And it goes back to the Devlin Report, which said that Anbar was lost. They just couldn’t see success. And Colonel MacFarland, a much more eloquent man than I, could convince us; he shaped it. The Marines really did not ever buy in. I think General Chiarelli [Lieutenant General Peter Chiarelli, MNC-I Commander] bought in long before the Marines ever did. I think Colonel MacFarland used to work on 5th Corps, and 5th Corps was the headquarters back then, so I think he navigated that water very skillfully.

Knarr: I think you’re right about Chiarelli.

Deane: And General Chiarelli got behind this thing from afar. [24:22]

Knarr: General Chiarelli was MNC-I, and Casey was the MNF-I.

Deane: Yeah! But they were supporting it a little bit from afar. They had to see where it was going. And then when General Petraeus first took charge, he went down there, but I was long gone by then. But the MEF was convinced that Sattar was a bandit and that was not the way to go. They thought we should stand behind Mamoun. So we finally got the MEF on board. The MEF came down, and it was General Reist and Soriano [Jim Soriano, State Department].

Knarr: Ok, State...

Deane: Yeah the guy from the State Department. We didn't have any PRTs [Provincial Reconstruction Teams]. There was none of that down in Ramadi. It was Soriano, Reist, and some MEF guys. So I went over to Sattar's house, and that's when Sattar showed up with like 20 of his people. We're sitting there in the back. Everybody's talking and all the tribal guys are yelling at Mamoun, calling him a terrorist. You can't judge a book by its cover, but Mamoun looks like a sleazy, small town politician to me, no matter what the culture, no matter what the area. They were yelling at Mamoun, and he's in this cheap fitting suit. Sattar is there. The Iraqis know when to speak. Those dudes know their place. We have no idea, but when one guy comes in the room everybody knows what chair to shift to and everything else. So this meeting has been dragging on for hours. So then Mamoun talks, but Sattar hasn't said a word, because the head dude gets the last word. And Mamoun knew where he stood in the pecking order. So, Sattar starts to talk and Soriano cuts him off. He starts speaking in Arabic to Sattar, and no one can understand what he's saying. Some Arab guy that was sitting next to me who came with one of Sattar's friends said "What's he saying. What's he saying?" The dude is speaking Arabic; I didn't know you spoke English! But, so Soriano cuts him off. Sometimes you worry about slighting these guys. Soriano unintentionally slighted him.

Soriano said, "I want three concrete things that we can do to show you that Mamoun is a good guy." Sattar was pissed, and the rest of them were mad, too. They were like, "You know that guy is AQ. Why do you guys keep supporting him?" He says, "Ok look, tell me three things so I can go back and convince him of that." I said, "Look, we all have bosses. They don't know you like I do." So, Sattar's three things were like, go on television and renounce AQ, vow to fight AQ at every turn, and there was something else like, Mamoun vowing on TV to serve the people and not himself. It never happened. [28:35]

Sattar had to be working somehow with the sheikhs in Baghdad. Somehow he got Maliki to issue this document. This thing was like this friction. We didn't really know how this thing was going to turn out. Maliki sent down this document that says, "Mamoun will remain

Governor, but Sattar will be in charge of all security and economic development in Anbar,” which sounds to me to be an awful lot like what the Governor should be in charge of.

Mamoun was happy letting Sattar take over as long as he remained the governor.

We filled the police. We filled the police full of able bodied men and then everybody else went in these ERUs [Emergency Response Units]. The guys that couldn't go in the ERUs just went into these neighborhood watch programs.

Everyone says that we paid off the tribes when it came to the neighborhood watch program.” Those dudes were just doing that at the start from Iraqi patriotism. There's a certain amount of, “Hey, I get out of the house; I've got an excuse to get away from the old lady,” but you know they're standing out there on these checkpoints wearing a road guard vest and carrying their own rifle for free, you know? I mean, how many people can you get to do something for free, every night? They saw that it was in their best interest and then it [30:56] took off.

Some say, “Oh, you paid off these guys that were fighting you.” Well some of them probably were, one or two percent, but 90% of them were guys that were just tired of the violence. Everyone says, “Oh they're criminals.” Well, you know the picture of when we first had that police meeting? There are like six guys in the picture. Well, two of them are dead. One of them was dead within a week, and the other was dead within a year. That isn't some guy who's a bad a guy. Those are guys that are actually out taking the fight to the enemy. [32:51]

Knarr: You also brought up another point. We didn't continue with that lesson of allowing the Iraqi Government to pay. What about the Sons of Iraq? They changed the policy. All of a sudden the Coalition was contracting those individuals to be at these fixed facilities. And now they're having a heck of a time trying to integrate them into Iraqi society. Twenty percent were supposed to go into the ISF, and the other 80% were supposed to be pulled into the other ministries. They're having a hard time with that. So, that's a big difference between what happened in Al Anbar and later in the Sons of Iraq [SOI]. You linked them to the government in Al Anbar and later on in SOI, they didn't feel that linkage, because they were working for and being paid by the Coalition. [34:07]

Deane: But, don't look at the end state, look at the start. The start was all about guys protecting themselves and protecting their families. The other thing was everyone said, “They need to join the Army.” Well, they don't want to join the Army They want to protect their family; they want to be a policeman.

Woodard: You said some of the lessons of the Awakening can be applied to Afghanistan. Are they being applied?

Deane: I teach a counterinsurgency seminar, and I make sure everybody understands what worked in Iraq. We kind of coach them to that. On the ground, I can't tell you. There can be completely different dynamics. Twain said, "History doesn't repeat itself, but it does rhyme," right? They have yet to get the population to buy into the government. It's a missed opportunity, but it's not due to the fault of the soldiers out there. It's just the number of troops. Not getting the people to buy in to the government is the problem. That has yet to happen. Colonel MacFarland said in one of his articles, "You know we had a leap of faith, but they had a leap of faith." If you're an American and you're looking someone in the eye saying, "Hey we're going to be there for you," we don't have a very good track record in Iraq, long term. Those boys took a leap of faith on us. Because I figured Sattar was talking to other leaders, I used to tell him, "You keep fighting us, but we're going to leave some day and it's going to be you and the Persians." And you know that's one English word them boys understood and they got. You'd see them all bristle. [36:58]

Knarr: You brought up Lioness Teams in one of your things. Let me ask you, how did the Lioness Teams develop? Who controlled them? Was it the females from the Engineers?

Deane: The head Lioness was Stephanie Cooper who was the Brigade JAG. She was a lawyer, very polite, very nice girl. When she slapped on her IBA [Individual Body Armor], she was as hard as the next man. Stephanie was in charge of it. It was the girls out of the FSB [Forward Support Battalion], all volunteers, rose out of the FSB and the Brigade Headquarters. We used them out of necessity really. I think the first operation they were brought in on was on the Ramadi hospital, because there were women in the hospital. Then we went into the university and we had the Lioness to separate the women and children out and search them. They got some extra training. It was pretty cool, because those women were out there soldiering! They had like little tab that said "Lioness." They'd wear that underneath there shoulder pocket flaps, and flash it to each other.

Knarr: That's great! Was that a brigade initiative?

Deane: Yes.

Knarr: You talked about FM 3-24. So many people talk about the results of 3-24, but 3-24 was really a result of stuff you and others did in 2005/2006?

Deane: Yeah, and you know Colonel McMaster broke some new ground up there in Tal Afar.

And then Colonel MacFarland was in Tal Afar right before he came down [to Ramadi]. I think obviously he was influenced by what he saw, but the other real leap that Colonel

MacFarland made and then we really made was we got the population, the rank and file population. [In Tal Afar], they got the Mayor of Tal Afar. He was bought in and the people there were pretty happy. The movement in the Awakening really was a people's movement. Sattar was a very charismatic man, a "people" kind of guy. He knew how to talk to them. The Awakening had their own IO [Information Operations] campaign. They handed out leaflets. They used to have commercials on the Sunni TV stations. I think Sattar's uncle owns Al Arabiya or something. That was always the rumor. The commercials would be like some police kicking in the door of a building. There would be a terrorist with a baby, and they'd arrest the terrorist and they'd take him out in chains. Then they'd have these Bollywood-like dancers come out and start dancing around. Guys in traditional costumes danced around with streamers and stuff. Then it would go back and show the police doing another good thing. There were these like skulky looking terrorists running around in t-shirts of terror, but they got out there and they sold it. And then, the guy who took over for Al Zarqawi, Al Masri. So, Al Masri gets on TV. He says, "All of the leaders of Anbar, except for Sattar who will be beheaded, can come on board and bow at my knee and kiss my ring. I will spare your lives. Otherwise the streets will run red with your blood, blah, blah, blah." [42:06]

Well, the next day, Sattar would be on TV talking about, "This is the people, and I will meet you at your liking. I will kill you with my bare hands. The streets will run red..." I mean it was excellent, you know what I mean? It just went on and on and on. You'd go over to Sattar's compound and they'd be like [42:38], "Shhhh, look, look, it's on, it's on." They'd be watching the news, and he'd be like, "Hey it's me!" Sattar's on TV talking smack, just straight up smack talking, and that's what they respond to. Sattar had movement of the people behind him.

Knarr: How did Sattar define the Awakening, and then how would you define it?

Deane: There were some people that joined in with the government and there were some people that were never going to turn. [There are PowerPoint slides on this] and in the middle is the green, the people who just want to be left alone. Sattar said that the people who either supported the Coalition or were neutral said, "Enough to the violence" and joined arms and took charge. The Sunnis [in Anbar] didn't see themselves as Sunnis. They saw themselves as people of Anbar—99% Sunni, but people of Anbar. They said, "The people of Anbar joined forces and took back their state in supporting their government."

Knarr: When you say joined forces, do you mean joined forces with the Coalition or just joined forces?

Deane: Using the Coalition, they joined each other.

Unfortunately, I don't think we really captured what happened. It really is about the power of the people. The thing in Iraq that I really see is the local police initiative or the local defense issue or whatever they're calling it now; that really is the key – to protect your family from intimidation...

The one thing that I never figured out until I got back home, almost two years later, was the amount of murder and intimidation that was going on. You just don't know if you're not there. Actually, I talked to somebody who was from 1-77, who took over after me. They said the locals said to us, "Didn't you see the number of vehicles going to the cemetery every day? You guys had to have known that all this stuff was happening." They said, these guys should know. AQ was out there saying that they were actually being paid by the Americans so they'd have an excuse to stay here to steal the money, which kind of makes sense if you're not very educated. We're not doing anything to help them. They're getting a funeral procession. I don't know how many people in an Arab town of 40,000 are getting buried a day; I never thought to even count it! But, you know, in Arab culture they don't want to insult you, so they're like, "Well everybody knows that." No, everyone doesn't know that. But they don't want to insult you by telling you something that you don't know. That's why they drive around town. And then the AQ guys are like, "Hey we're on the payroll of the Americans. How do you think I can drive through town all the time?" Well, we didn't know who they were, and they all knew.

Knarr: That's an interesting comment, because I read that in another document [the Al Anbar Anthology by the Marine Corps], where people really thought that the Americans and AQ joined forces to fight them. I mean, that's how bad it got! That's incredible! In fact, it almost makes you sick to think that that that's the perception that some of the Iraqis had. [48:13]

Deane: Yeah, but they would send out that message. The brigade shot terrain denial fires up in the Shark Fin. We always took rockets from there. They figured out what type of mortar gun we were going to shoot. They'd do the math, and they'd have ISR if they'd catch them, but routinely they'd just shoot terrain denial fires up there. So, as the Awakening started spreading, the guys from the Shark Fin started coming...

Knarr: Yeah, Jassim.

Deane: Sattar said, "Why are you guys shooting artillery in there?" I said, "There are mortar men in there. They're trying to get them." He said, "AQ is going around telling people that you are scared like women, so you are just shooting widely in the hope to kill them. But they have

magical powers, and you're bullets don't affect them." Shooting like women is not something that goes over well in that society.

Knarr: Please talk about the Tactical HUMINT Teams.

Deane: The THTs are out there, and they've got the Company Commanders and all the officers from the police on the payroll. Instead of reporting up their chain of command, we're paying them \$50.00, and they're like, "Hey, look we've got information," but we're actually derailing their entire system.

Knarr: I read that in your After Action Report. That's incredible.

Deane: And then we got this whole thing, and it goes back to what the rules are. I understand there have been cases where people were running sources. The reports that I took were not entered into the information database, because I was not a trained THT [only a trained THT member could enter a report in their intelligence data base].

Knarr: Before we started this you talked about Mahmoud Latif, MML. And I probably need to talk to Lovejoy about that too?

Deane: Yeah, you need to talk to Mark Lovejoy about that. My understanding was that Latif set up something similar to the Awakening, but without any Coalition support. He didn't want Coalition support, and the Coalition didn't want to support him. He tried to get the sheikhs together to fight AQ. The story I heard from the Sheikhs was that they were all supposed to meet in the Saddam Mosque. Mamoun was supposed to pull security, and they went in there. AQ rolled in, shot up the mosque, and shot a couple of the sheikhs there. Then [AQI] went pretty much house by house of the leaders of the sheikhs and executed them. So either they were executed or escaped to Jordan.

Another thing is, the MEF was trying to do this tribal business with guys who were identifying themselves as tribal leaders in Jordan. These people might have been the sheikh of the tribe before hand, but they fled to Jordan.

I don't know what I could have done, but you know we probably could have done something. Now, ultimately, Bear Johnson parked a tank out front of Sattar's house. It didn't really do much good, but it kept the suicide bombers down for a while. How do you protect these guys? A lot of it is building joint security things with them and just being there with them. Ok. What else?

Knarr: This was very good. Thank you.

Attachment:

Al Anbar Rescue Movement Meeting Minutes 14SEP06 [Provided courtesy of Colonel Tony Deane, former commander TF 1-35 AR]

Al Anbar Rescue Movement Meeting Minutes 14SEP06 [Provided courtesy of Colonel Tony Deane, former commander TF 1-35 AR]

Doc (1) 5 pages

Origination: Sheik Sittar Bazea Fteykhan Abu Risha (Al Anbar Rescue Movement)

Procurer: LTC A. Deane

Translation: Dragon

In the name Of Allah Most Gracious, Most Merciful
((Koranic Verse))

Memorandum / letter

Al Anbar 14\9\2006-09-15

Mr . President of the Parliament (Speaker) Dr. Mahmood Al Mash'hadani most respected

Mr, Prime Minister Noory Al Maliki most respected

We greet you in Islam and Peace from Anbar that has risen in the face of terrorism. We have come brothers of Anbar Tribal Sheiks and Leaders and held a conference (The awakening of Honorable Anbar Tribes). Today we announce the good news the beginning of the end of Terrorism in Anbar Province, we hope that you will support us by legalizing our RESCUE ANBAR COUNCIL that was elected by Anbar Citizens with council's members names enclosed hereinafter.

Allah Great, Allah Great and Glory to great Iraq .

Signed

President of the conference (The awakening of Honorable Anbar Tribes)

Sheik Abdel Sattar Bazea Fteykhan Abu Risha

List of Rescue Anbar Province Council Members:

01- Abdel Sattar Bazea Fteykhan Abu Risha	Aby Risha
02- Wesam Abed Ibrahim Al Hardan	Abu Ayetha
03-Moayad Ibrahim Hammady	Abu Diab
04- Abdel Kareem Yousof Mohamad AL A'sal	Abu Diab
05- Hameed Farhan Al Hayeth	“
06- Mohamad Ali Sleiman	Abu Oubeid
07- Taher Sabbar Bdeywi	Abu Alay El Jasem
08- Ryad Hameed Yousof	”
09- Sha'lan Noory Khalaf	Abu Shleyb
10- Jabbar Hameed A'jaj	”
11- Kamal Hammad Me'jel	Abu Risha
12- Khaled Abboud Saleh	”
13- Layeth Adel Hammad El Shoka	Abu Diab
14- Fares Ibrahim Hanoosh	“
15- Awad Ali Hussain	”
16- Majeed Gbayel A'bed	Abu Benhan
17- Faysal A'yed Mohamad	Abu Shleyb
18- Abdel Jabbar Bazea Fteykhan	Abu Risha
19- Ahmad Abood Eyada	Abu Shleyb
20- Jbayer Rasheed Nayef	Abu Alay El Jasem
21- Waleed Khaled A'rarak	”
22- Ali Mehdi Dahi	”
23- Fawaz Khalaf Hanshal	El Garagol –Zanora
24- Ahmad Jasem Hammadi	Abu Assaf
25- Mezher Hameed A'jaj	”
26- Faysal Najress El G'ood	Abu Nemr –Hit
27- Fassal Reygan Najress El G'ood	”
28- A'bed A'ssaf Ghadban	”
29- Saeed Hammood Al Darweesh	Abu Khalifa-Khalidya
30- Yaseen A'bdel Jabbar Matar	Al Kobaysi –Rutba
31- A'bdelhameed Zyab Khalaf	Al Jahayfa – Haditha
32- Turki Saleh Ouwayed	Abu Sha'ban –Jazeera
33- Qayes Hattab Sharmoot	Abu Alay El Jasem
34- Mohamad Mahmood Nattah	Abu Shleyb
35- Ali Hatem A'bdelrazak Ali Sleiman	Abu A'ssaf
36- Trad Hammood A'ftan	Abu Mahal –Al Qaem
37- Ibrahim A'bed Hamad	Al Hamadani- Hit
38- Jbayer Saleh Khalaf	Al Laheeb – Hit
39- Khaleel Ibrahim Mekhleef	Abu Hayat – Haditha
40- Helal Khalaf Ouwayed	Al Malahema-Khalidya
41- Faysal Sharmookh Bdeywi	Abu Risha

**In the Name of Allah Most Gracious, Most Merciful
Rescue Anbar Province Council Proclamation.**

With Allah's Help and the reliance on the outstanding zealous, heroes sons of Anbar Province decided to hold this conference.

In respect to actual situation that our province has been going through and what catastrophes has brought upon us where brother kills his own, son his father, where the peaceful passing by no respect . For all that the zealous and those attested for to be honorable, for their love of their country and to repair what could be repaired, and whatever has stand those catastrophes we have declared the following :

01- The return of Honorable status of Sheiks, those Sheiks who did not support terrorism in any way or means, to form Anbar Sheik Council.

02- Hold Free Election among all tribes to elect the members for: Rescue Anbar Province Council, where all sons of Anbar will be democratically represented without any illegal pressures.

03- Forming of Police and Army from Anbar sons, Hiring Process and appointments should be in coordination with the sheiks where sheiks will issue affidavit in which they confirm the good civil conduct of the recruits from their tribes.

04- Provide security for Highway Travelers, and in roads within tribal areas.

05- Condemning Terrorism wherever and whenever it is found, disclaim any attacks against CF to allow an open dialogue in order to draw a new road map for our Province.

06- Stop all arms holding in public streets, except for Police and Army.

07- Respecting the Law, supporting the judicial system, so they can uphold the Law.

08- Open dialogue with ex-Baathist members who has not committed any crime against Iraqis, and did not support terrorism, helping them get jobs.

09- Immediate rebuilding of agriculture, industrial development, and reopening of closed industries in order to prevent unemployment.

10- After ratification of the proclamation by tribes we will take the following action. Any person who give refuge to any terrorist whether Arab or Foreign or Iraqi shall be held responsible for his actions by his tribe Sheik, by surrendering him to proper authorities.

11- Open Dialogue with CF in order for them to schedule withdrawal from the Anbar after complete formation of Police and Army of Anbar Province.

**In the Name of Allah Most Gracious, Most Merciful
Meeting Minutes**

We relied on Allah and met as Rescue Anbar Province Council with all its founding members on 14th September 2006 and decreed the following by unanimous decision:

First-

- 1- Elected Sheik Hameed Farhan Al Hayeth President
- 2- Elected Sheik Saeed Hammood Al Darweesh Vice President (First)
- 3- Elected Sheik Taher Sabbar Bdeywi Vice President (second)
- 4- Elected Mr. Fadel Mekhlef Daye'h Secretary General

Second-

- 1- Elected Sheik A'bdelsattar Bazea Fteykhan Abo Risha Anbar Province Governor.
- 2- Elected Sheik Wesam A'bed Ibrahim El Hardan Deputy Governor

By thee our meeting has ended with Allah's Blessing.

Signed
Council President
Sheik Hameed Farhan El Hayeth

16 January 2011

Subject: Interview with Major Damon Mitchell, USA, former Commander, Bravo Company, 16th Engineer Battalion, 1st Brigade Combat Team, 1st Armored Division

Major Damon Mitchell commanded Bravo Company, 16th Engineer Battalion in Tal Afar from April to late May 2006 and then in Ramadi from May 2006 to early March 2007. The 16th Engineer Battalion was attached to the 1st Brigade Combat Team, 1st Armored Division (1st BCT/1st AD) also known as the Ready First Combat Team (RFCT). Major Mitchell was the Brigade Engineer Officer and then took command of Bravo Company, 16th Engineer Battalion in April 2006.

The unit's mission was general construction and route clearance. It was in charge, or supported the building of many of the combat outposts in Ramadi during the latter half of 2006 and early 2007. Most people think of the infantry and armor units when discussing combat operations. But in a counterinsurgency environment, the combat engineers, sapper, construction battalions (CBs or Seabees) become critical to the mobility/counter mobility fight as well as to clear hold and build phases.

Major Mitchell was interviewed in Fairfax Station, Virginia, 19 December 2010.

Dr. William Knarr. Please talk about Bravo Company, 16th Engineers. How many people did you have and what type of equipment?

Major Damon Mitchell. In Tal Afar I had three platoons, basically what I am supposed to have on MTOE [Modified Table of Organization and Equipment] [10:25.9] The company strength was 86.

But I had two of my own platoons and one attached from Charlie Company, 16th Engineer Battalion. When we moved to Ramadi, we grew. I had two organic platoons and an Assault and Obstacle platoon from Alpha Company, an Assault and Obstacle platoon from Charlie Company, and then a line platoon from the 40th Engineer battalion. Later on I received a platoon from 9th Engineer battalion. So I ended up with five platoons and about 150 people counting my headquarters section. Every once in a while, we would get a Marine platoon attached for missions. So I was running sometimes six platoons depending on if I was working the Marine sector. Lieutenant Graniero and his boys would linkup with us under my control. What kind of equipment? I will talk about the mission set and then I will talk about equipment. [11:42.8]

Mission set. We had a general construction mission, explosive ordinance disposal, security escort and route clearance with one route clearance package.

Additionally, there is a big difference between going into the city and then going to the rural areas. When you go into the city, things are already hardened and therefore you end up reinforcing obstacles or buildings. When you go into rural areas, you are basically building from scratch. So for general construction, I had bucket loaders, front end loaders, two D-9s [Caterpillar bull dozer], some up-armored D-7s [Caterpillar bull dozer], M-916 tractor trailer trucks with trailers on the back to move the equipment. In addition, I owned a 20-ton crane (unarmored). Additionally, M-113s [personnel carriers], sniper rifles and other sights and weapons systems to support local and area security internally to include providing organic over-watch.

For route clearance, I had Cougars, Buffalos, Huskies [mine protected or engineering type of equipment for carrying personnel and/or clearing roads]; we also had sparks rollers that attached to the front of the RGs [RG 31, Armored Mine Protected Vehicle] and to the Humvees [High Mobility Multipurpose Wheeled Vehicle, HMMWV] and some of the CROW [Common Remotely Operated Weapon System] systems. We ran Chameleon for our CREW [Counter Remote Controlled IED Electronic Warfare] devices, a Marine system. So the platoon on EOD escort was organized with gun trucks and usually at least one CROW system because, they are just a great weapons system.

Knarr. Okay, so you get down there in May. Where did you go first?

Mitchell. I went right into Camp Ramadi and my first mission within a few days was putting in Eagles Nest on Base Line and Easy Street in the Mul'aab. I was attached to 1-506th Air Assault out of Corregidor. [The Mul'aab is west of the 1-506th AA symbol in Figure 1.]

Knarr. What was that like? Did you just get down there and then all of a sudden you were sent on a mission?

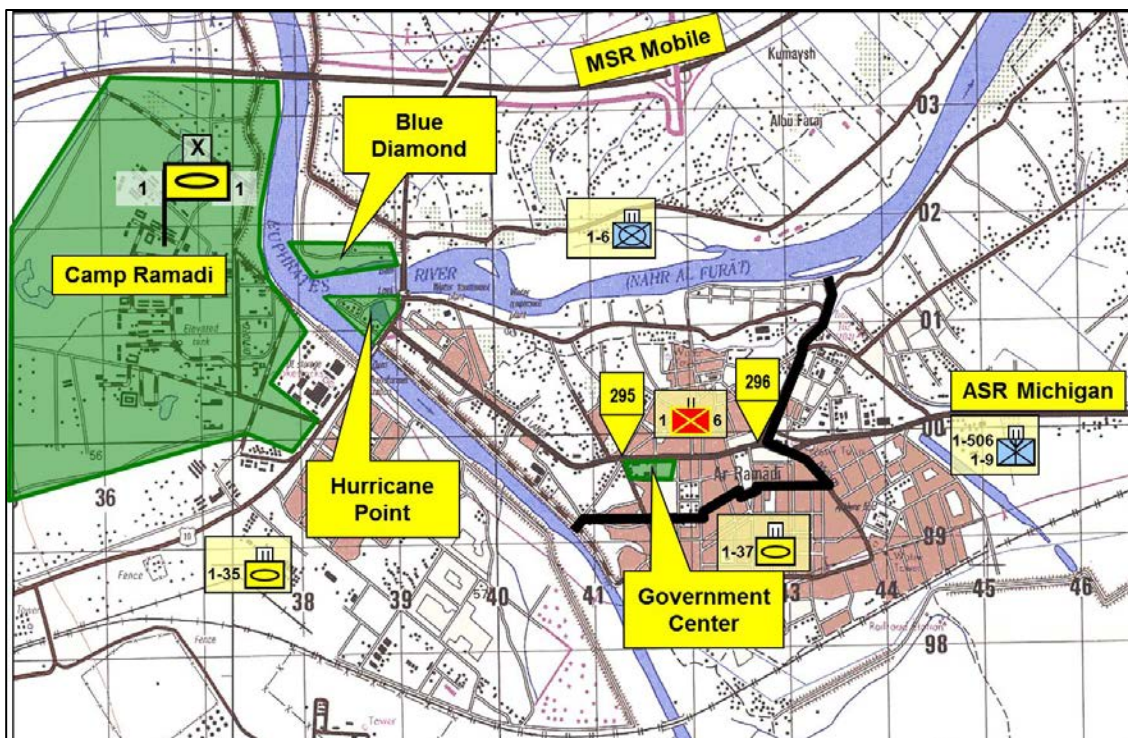

**Figure 1. Abbreviated Area of Operations
(Diagram developed from 1/6 Marines presentation)**

Mitchell. Let me tell you about my Battalion Commander getting blown up. Within a few days of being there, he called me and said “We are going down to Corregidor [Base camp for 1-506th, Figure 1], bring a platoon leader.” It had to be important because you don’t go down Michigan in the day. We went and, somewhere between the Government Center and OP Horea, he was hit with a rocket [See Figure 2]. Immediately after he was blown up, we were hit as we were trying to push him through the intersection. Later on we find the insurgents had video-taped the incident and put it on the web.¹

So we get into Corregidor and LTC Webster says, “Okay, go link up with the battalion commander.” I take my platoon leader, Jack Morrow up to the battalion conference room. [18:26.9]

¹ The banner on the bottom of the video says, “Burn HMMWV with missiles, [signed] Islamic Resistance Group in Iraq.”



We are sitting in the OpOrder [Operations Order] brief, and we start getting attacked. Corregidor is under fire. And it's not just rockets. Al Qaeda in Iraq (AQI) is out there conducting a complex attack on one of the OPs [Outposts]. Everybody is grabbing their weapons and I am running outside, and they are like, "No, we've got briefings to do, they've got it." So we continued with the briefing and you can hear, "boom, boom, boom!" Even in OIF-1, whenever we had rockets it was, "one hundred percent accountability. Grab your weapons, man the towers!" But this guy, "We've got work to do; I don't care, this happens all the time, drive on." [19:56]

Knarr. Was this before your RIP [relief-in-place] or after?

Mitchell. This was during the RIP. We didn't really have a RIP because the unit we were paired with was a construction unit. I don't know how much they did, but we did learn some things. We got some of their designs for their OPs. They had this COP in a box type of thing with the BOM [Bill of Materials] and things you needed to put it together. We did take a lot of that because they were construction guys and they helped out in terms of designs in how to build

things. So my RIP was taking their mission set and taking over their real estate on Camp Ramadi.

² Insurgents videotaped the attack and put it on the web. 16th Engineer Battalion downloaded it from the web.

Other than that we were doing our own thing; within the first couple weeks, we had three guys killed who were from an attached platoon. Probably the most dangerous mission was the EOD escort, because they were hitting first responders. That by far was the most dangerous, most lethal, because they [the first responders] were going to where these bombs were and AQI was targeting them.

When we went to Corregidor, I had about four hours, sat down with my platoon leader and I said “Alright Jack we have to figure this out. What do we need?”

We got the mission, immediately called back to my company on the DNVT [secure communications system] and said “Get Bravo Company ready and this is what I want you to bring.” We brought an up-armored dozer, gun trucks, HEMTT [Heavy Mobility Tactical Truck] wreckers for the barrier work, and then we borrowed one of the bucket loaders for barrier emplacement from 1-506th. We had our own, but it was a case loader and it was not reliable. It was up-armored, but it was always down. We had a Cat [Caterpillar] loader, which was awesome but it wasn’t up-armored, and I wasn’t willing to take my guys out there because they would have gotten shot; there is no doubt in my mind that they would have been shot. So that’s what we brought.

We were supposed to go in that night, but for some reason the route clearance guys got hung-up all night long. It was a unit from the 54th Engineer Battalion—I am not sure which company it was, but 54th was tasked to do this mission. So they did route clearance first and we took my dozer and dug the road up. Do you know the water tower down there on the eastern side near Saddam’s mosque? It’s directly south of Saddam’s mosque; right next to Eagles Nest. We found a lot of bombs there underneath the road, so we dropped the blade and just dug it up because AQI had dropped and repaved it and resurfaced it. We were out there for three days before we took a rest. And then Lieutenant Colonel Clarke [1-506th Commander] came up on the net and said, “You need to bring your guys in, that’s enough.” So we came back and rested for like five hours and then went back out again.

The SEALs had sniper teams out and they were shooting people. But the shots kept getting closer and closer, and my fear was that sooner or later somebody was going to get close enough to call for fire and/or we were going to have a sniper problem. That’s why I had kept my guys out there; I wanted to get it done as soon as possible. The longer we were there, the more likely we were going to get hit with something. And we did. They threw some mortars at us and stuff but fortunately they weren’t very accurate. It was a

company mission, but a platoon execution. So essentially we became 1-506th Task Force engineer for that period of time. It took us almost two weeks.

We stayed in a warehouse out back. No air conditioning; it's June. We couldn't take showers, because they didn't have enough water. No ice, my First Sergeant tried to run it to us, but by the time he got there, most of it was melted.

We went with the 1-506th and out to OP hotel and cleared those buildings all the way up to Saddam's mosque. As a matter of fact, I had to call my First Sergeant and tell him to send out a demo[lition] truck because we couldn't do it mechanically. We destroyed the foot bridge; that's really dead space where they couldn't see and all the buildings leading up to the thumb [contour of the road intersection next to Saddam's mosque]. Then we just started knocking buildings down.

At that point, we got some D9s and we did some OJT [on the job training] with my guys for the D9s, because we didn't [normally] have them. We used both mechanical and explosives to clear dead space all the way up to the thumb. I remember standing on the corner on the radio with the Soldiers in OP Hotel saying, "Please stop shining your lasers out here because you are scaring me." The snipers are checking for dead space to see if they can see or not, but I am standing out on the corner—I've got guys out there, "Don't shoot!" Because you don't know if they are just checking for dead space or getting ready to fire, and I don't want to be mistaken for AQI. That took a week. [32:06]

Knarr. We are still in the June/July timeframe. What was next?

Mitchell. COP Iron. ECP3 [entry control point] got hit with a VBIED [vehicle-borne IED]. It was on the western side of the river at the train bridge. Right when you cross over the train bridge on the western side. There was no way to get across the bridge at that time, because the railroad ties were still intact. You couldn't take wheeled vehicles across it. Then we had to go down and clean it up. It was a large complex attack; it blew the shit out of the ECP. They started off with the VBIED, then the mortars, then direct fire. The Iraqi Army [IA] guys got hit pretty hard. I think the Americans were okay, it was a MiTT [military transition team], but the executive officer from Charlie Company, 40th Engineer Battalion was wounded because he was on site. So active duty army guys now replaced it out of 1-36th, B Company I believe. You know, 1-37, but it was the infantry company that was attached to them out of 1-36th.

So Brigade said, "We need to put in this combat outpost on the other side, it's already partially there, but it's really an ECP, but you can't sustain anything." My company was

a force provider during the mission. I was in charge of cleaning up the VBIED, but I wasn't in charge of anything for COP Iron. I gave them sappers to blow the railroad ties out of the way and make it trafficable by tanks and Humvees. Going back to what John Paul and I looked at in Hohenfels-Grafenwoehr prior to deployment, now we were starting to flank them and do exactly what we had talked about [pre-mission planning in anticipation that they would go to Ramadi]. Come in from the south, southwest and push them into the southeast. That's when I realized that the stuff we thought about seven or eight months ago, we were actually doing it. Then COP Iron went in and we had already put in Eagles Nest.

Now we've got two combat outposts in. The next one I believe was OP Hawk, [see Figure 3, northeast corner]. OP Hawk was taking down the hospital. We hit the hospital with the 3rd Battalion, 8th Marines (3/8 Marines), LtCol Stephen Neary was the battalion commander. It took us all night to clear the building and then we started the combat outpost build to the east of the hospital. I had one platoon working on that with the Marine sapper platoon. It was actually a pretty simple mission. AQ knew that we were coming, so they vacated. We had taken the hospital back and essentially locked down the parking area for the hospital with barriers and whatnot.

I got called out at 1 o'clock in the morning or so to go change everything around again. We built a combat outpost at the mansion that was just to the east of the hospital. We had line sight direct with the hospital, so we could secure the people who were going to and from the hospital.

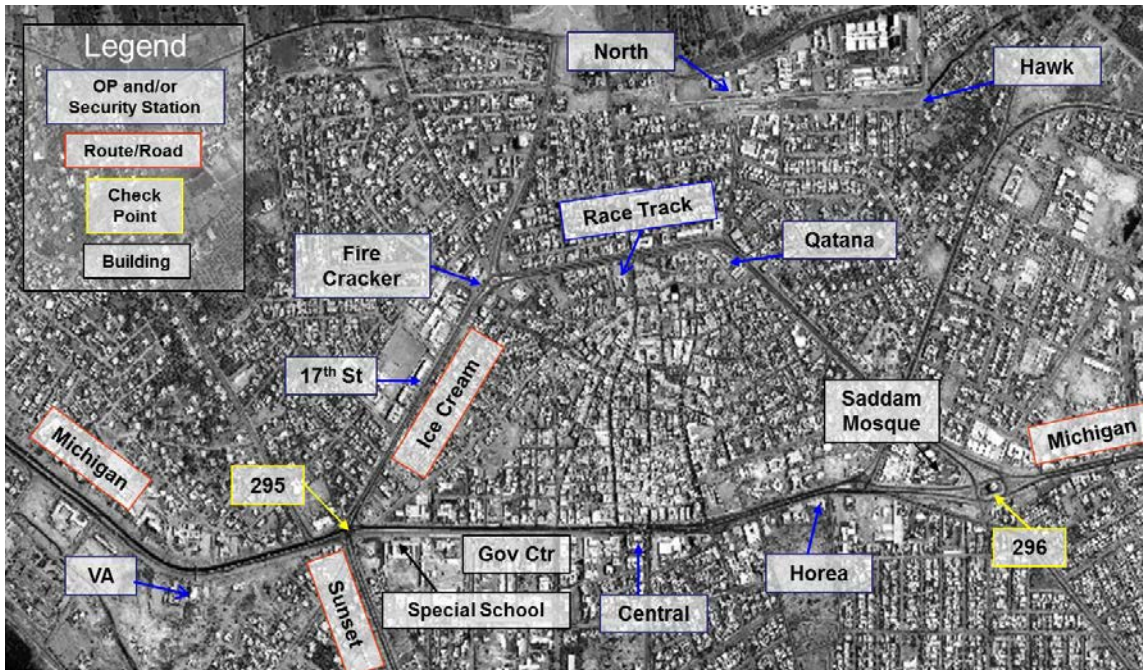

Figure 3. Ramadi City Landmarks

I got called by the deputy commander to link up with him “on the ground in 30 minutes and bring one platoon.” So, I go to meet Lieutenant Colonel James Lechner. He said, “We need to lock this place down.” He pulls out the map and we’ve got red lenses and we are standing out by my Humvee. My concern with locking the place down was that it would be difficult for people to get into the hospital.

His solution was to, “Secure it and make an AXP [ambulatory exchange point].” I said okay, but unfortunately it didn’t work. The people and sheikhs were irritated because it was so confusing and time consuming to get into the hospital. The next day I was told to go back out again to clear some areas and move all the barriers. We went out there and just put some serpentines in so it would slow people down, but allow them to use the various entrances.

As a brigade, we were trying to figure out how to get these people on our side. We went in lethal, because at the time we knew it was lethal, but at this point, we kind of knew that we had to work the softer side.

After that we got called to do the Government Center. That was a long mission. We started that in August and, when we were in the middle of it, I went on R&R.

We also did other missions. We had done several IP stations. Those are easy to set up. The site was normally chosen by the brigade. As an example, how do you secure a pump

station from getting blown up? You put an IP station on it. We probably did four or five IP substations around Ramadi, then we cleaned up several VBIEDs after they [AQI] blew them up. There was one in Tam'eem, but across Michigan; it was an IP station that was hit with a VBIED and the entire roof collapsed and we had to go clean it up. We were doing that all the time.

We were the emergency response consequence management piece when it came to IEDs/VBIEDS. That was an enduring mission. You didn't know when it was going to happen, but you were always prepared to do it. The same with route clearance, and EOD; they always needed the security escort. I rotated all of the missions between platoons every 14 days. The Soldiers get complacent and lethargic and aren't as vigilant [if the mission doesn't change every once in a while]. I'd be on the route clearance [check ride with the platoons] and I'd say, "Did you see that?" It would be like the tenth day—"Ah no sir, that's not anything." "Get it, interrogate it." It was important that we rotate the mission, because these guys were getting tired, they were doing the same thing over and over again.

The Government Center. We broke it up just like obstacle belts and groups and numbered it using standard Alpha Numerical Naming Convention, you know 1Alpha1, 1Alpha2, 1Alpha3 as far as the buildings go depending on what zone they were in. That was a long mission. We learned a lot but it was a mess. Humping that stuff every day and walking over the remnants of five stories to get to the next building that you still have to clear was hard work.

The Government Center was August. It wasn't done when we left. We finally got pulled off and they contracted for rubble removal. We just didn't have the equipment.

Knarr. That was in the Government Center area?

Mitchell. It was right across the street. I had three platoons working that—one in Alpha, one in Bravo, and one in Charlie—they would work that each night. I would tie all the blasts in at the same time. Because I was locking down an MSR. When you lock down the MSR, you can't do that for a long time, but we only worked on that stuff at night.

Knarr. When you locked that down, did they have to divert traffic up through Racetrack and around?

Mitchell. Nope I just locked them down, "boom," went out with the dozer, cleared any rubble that was on the road and opened it back up again. Literally within 20 minutes it was

done. That's why I wanted all the blasts going at the same time. We might do that twice a night, but I was getting as much as I could get done at that point in time. You know, gun trucks blocking the roads, people sheltered. And I knew why we were clearing the area. They [the insurgents] dug tunnels into the back of these buildings and into the ground and underneath walls and they had cached weapons and munitions. When we found that stuff, we didn't pick it up, we just blew it up. We put it in the corner and we may have put an extra satchel charge on it, but we left it to blow up with the building.

Knarr. Was the *Stars and Stripes* article on the Government Center? [15.27.2]

Mitchell. That was the one by Monte Morin, where he quoted me comparing the rubble at the Government Center with a scene from *The Terminator*.³ The mission at the Government Center was to clear dead space because AQI was attacking the Government Center. So the Government Center was August, September, October. Not only were we getting the big stuff, but we had to rubbleize it. So we were doing maybe two days of demo and one day of rubbleing, two days of demo one day of rubbleing.

Knarr. What's rubbleing?

Mitchell. Just breaking it up so you can move it. We moved it initially, but later on we contracted it [out]. We actually used some of it in Qatana for the mud. The tanks were just destroying everything when we were building Qatana and there was so much mud. We ended up using a lot of that stuff to fill in some of the holes that were dug up by the tanks and the M-88s [recovery vehicle].

Knarr. What was next? 17th Street?

Mitchell. I was a force provider for that one. That was actually Charlie Company, 9th engineers. He had one platoon that was his; I had one of his platoons all the time. Carl Dick was the guy that did that one. Major Dick, good dude. He's in SAMS [School of Advanced Military Studies at Fort Leavenworth] right now. 17th Street was the IP Station and Firecracker was the COP. They were right next to each other and they ended up combining them. They knocked down the middle wall and combined it and made a huge motor pool. That's what Apache, TF 1/6 Marines took over.

Knarr. What was your next mission? Qatana?

³ Monte Morin, "U.S. Troops Razing Ramadi Buildings to Renew Security," *Stars and Stripes*, Mideast Edition, 2 Sept 2006.

Mitchell. Must have been, because everything else was general construction.

Knarr. Talk about filling sand bags in front of the DFAC [Dining Facility].

Mitchell. One of the problems we were finding is that we were going out to build a combat outpost and we were filling sand bags on site. We needed to fill them before we got there. So somebody smarter than me said, "Let's just dump dirt out in front of the DFAC and in order to eat you have to fill a sand bag." I was like, "That's a great idea!" And somebody said, "Hey Mitchell, you get to provide the dirt." So we put it out there and it worked. We just saved time on target.



Figure 4. Filling Sandbags at the DFAC

It was every meal: Breakfast, lunch and dinner. I think we had 7,000 folks or more on Camp Ramadi. If you just do the monkey math, that's easily 21,000 sandbags a day. It saves a huge amount of time.

Knarr. That's neat.

Mitchell. I think it was Lieutenant Colonel Dan Snead's idea. He made LTC as our XO.

I got the Qatana mission on the 21st of December and it kicked off on the 21st. The Marines initially went in and I supported it. I gave them one of my dozers and a platoon to help. Then I watched UAV [unmanned aerial vehicle] feed as one of my bulldozers got burned with a Molotov cocktail that AQI had thrown into the cab. Watched it smoke all day. One of my guys was in there and he kept kicking the door open. He got shot and it broke his hip. So Graniero and one of their gunnery sergeants grabbed him to pull him out and his leg folded over on him. Then they couldn't fight their way back to recover the dozer so AQI burned it. But we got it later on and it was still operational.

So then I got a call, I guess it was 2 or 3 o'clock in the morning, "I need to see you." It was LTC Webster. "We are leaving at 5 o'clock, we are going down to see Qatana." Okay. That's where LtCol Bill Journey, TF 1/6 Marines was. This is the first time I have ever met Journey. I think they were fairly new in sector. So this was a really big mission, and they had a couple of buildings blown up on them. Squad got the floor taken out from under-

neath them, they were in a bad way. So LTC Webster and I went down and they flew a UAV for us to see Qatana. Journey did not want us going down to do a recon on foot. Too hot. So they flew a UAV and I took my camera out and I taped it on my camera off their screen and took it back and briefed my guys on it. That night we executed.

It was a mess. Marines got an RPG through one of their HMMWVs that night that killed a kid. Very lethal. Enemy snipers were definitely out; they were all over the place. But my biggest problem was traffic control. I was told through the grapevine that “Mitchell, Bravo, 16th Engineers, you are the main effort. Whatever you need we will get it to you.” It was much bigger than what I was doing; I was executing, but there was a lot of stuff happening at Camp Ramadi where they were staging all the barriers and all the stuff that had to come in, and CBs [Navy construction battalions] were attached. Unity of effort was there, but unity of command wasn’t. It was like pulling in random folks from around the battlefield; accountability was hard. We had accountability through trip tickets and stuff like that, but it was just very difficult to track all these folks.

I guess it was about six or seven city blocks that we had taken down and secured. I knew that there were a couple of buildings that were booby trapped. House-borne IEDs or whatever the flavor of the day was, were embedded in most of the structures, so we just did vertical entry. We jumped on top of the Buffalo, jumped on top of the buildings, and then blew them up that way. Breached through the top and then hung suspension charges so that we didn’t have to go in, just to alleviate the danger of walking through entry ways where there is something that could go off.

This created some problems, because with suspension charges the pressure will take down the building but it also creates an overpressure into the ground and blows out pressurized water mains. That’s where all the flooding problems started. Compounded by the fact that we had tanks and Bradleys pulling blocking positions down the road and they were crushing these water pipes too. It wasn’t just us blowing buildings, but that’s where it started. An NCO [non-commissioned officer] told me later on as we were leaving that morning in a convoy, I was lead and he was trail, that he saw the water come back on, and watched it explode.

Another problem was that when we hit those buildings, some had weapons and ammunition caches and some had IEDs, so we would get secondaries [secondary explosions]. So not only were we putting 400 pounds of explosives into the building, we were getting secondaries. I mean you’d hear “boom, boom, boom, boom, boom,” and we’re thinking,

“Whoa that was only one charge!” Something that was supposed to take about two weeks ended up taking from December into February. [31:27.5]

We had gone for a couple of weeks and COL McFarland came in. I’d found VBIED factories, chopped up cars, lots of leaf springs, just stacked up to the roof. A couple of hundred bags of urea nitrate just stacked to the roof in this one area. He came down and I said, “Sir this is a VBIED factory.” He was kinda like, “Yeah right, a VBIED factory?” I said this is urea nitrate, and I cut it open and the stuff was very pure, white crystal—just high nitrus, nitrogen. [32:11.2] Then he started to see it, “Yeah we’ve got something good here.” It was a major cell. There was a room where they were torturing and killing guys, and we found pressure plates, pipe cutting, acetylene torches, all this stuff. I went back into another one that we had cleared with the dog and all of a sudden I looked down and there was a pressure plate sitting there. It wasn’t armed but it was buried in the sand. So I yelled, “Get the mine detectors!” We went through and pulled out 120 mm mortar rounds. Just unbelievable. It was a huge find.

In the corner, there was hole and in there were these perfectly wrapped Aim 9 rockets still in the tubes, still in the plastic, sitting in a hole in the corner of this building. We picked them up and put them in the back of the truck and took them back. We didn’t blow anything else up after the flood.

So I am taking COL McFarland through. The reason I was walking him a certain way, through the water, was because I got my Humvee stuck in the mud and they had to get a crane to pull me out. So I was walking through the water and it was above our knees. He’s like, “You are doing this on purpose.” I said, “Yes I am. Your guys think that driving through the mud is the path of least resistance,” I said, “Just wait.” We get to where we need to go and turn around and they are all stuck. And we had to pull his PSD [personal security detachment] out.

Back to the flood, some called it Lake Qatana. I was driving to see LtCol Journey and, referring to the water, he asks, “Are you going to be able to fix this?” I said, “No, not unless you turn the water off; please turn the water off.” The problem was, the only time the residents were getting water was at night. It was the only time they were turning it on. We had crushed all the water mains, but at least parts of Ramadi were still getting water, so they finally shut it off so we could fix it. I tried everything and finally we had the Iraqi water services guys come down and fix it.

Knarr. What about the building for the Qatana Police Station?

Mitchell. The bottom line was that when AQI booby-trapped those buildings, we had to go to a place and start from scratch.

The new building didn't dominate the terrain by any means [see Figure 3, above, above the Saddam Mosque]. It was low, so we were stacking 20-foot containers to get some elevation so we could see down the avenue of approach to the north and west and east.

Knarr. Why did you pick the lower elevation?

Mitchell. Because we had to have overwatch on those avenues of approach and all the other buildings were booby trapped. We couldn't go into them. Graniero showed me pictures saying, "Sir this is what I found and this is why we pulled out."

Knarr. Capt Graniero showed me pictures of some of the places and one of the places had 120 mm mortars rounds embedded in the walls. [39:51]

Mitchell. He said he went to the Ministry of Oil; [in fact] he went to the building beside it. So we picked the building that we thought AQI had left alone, i.e., not booby trapped. The building that was least likely to serve our purpose. The one that didn't seem to have any value as far as overwatch, altitude, location. That one was probably safe.

It was kind of interesting that we turned into the 911 unit for the brigade. We were called if the mission exceeded someone else's capability and sometimes that was when it turned into a crisis. As an example, Scott [Graniero] was thankful we showed up because it was a huge undertaking.

Knarr. Capt Graniero said you used a different technique in Qatana; that you went from the top down, but that he used a different technique on the demolitions he did.

Mitchell. It depends on the type of building. As an example, he ended up taking down an old IP station. They couldn't go through the top because the walls weren't intact, and you can't use suspension charges for that. Suspension charge technique uses the overpressure that is contained by the existing walls to destroy the building.

It also depends on whether it's safe to go in the building. The one in particular that I was really worried about was actually a little bit taller. I decided to blow it up because I knew it was rigged, and we went through the top. [42:40.8]

Knarr. What else happened at Qatana? Scott [Graniero] said something about you acting as a medevac and rushing people back to an aid station or medic.

Mitchell. There were two people. One of them was a kid in the hatch of an M-88. A sniper took a shot at him as he was standing up and out of the hatch of an M-88 to take a leak. I just grabbed him and threw him in the truck and got him down to Firecracker. Had he not stood up, the guy would have shot him in the face and he would have been killed. He was lucky that he had to take a leak at that point. [44:44]

The second one was Sergeant Rodriguez out of 2-37 Armor. Two days later, same spot. He took one through the shoulder. Graniero was down the road and yelled, "Hey we got somebody hit, we got somebody hit!" I ran up and the guy [AQI sniper] is still smoking rounds. It was me and my driver Lee. (Lee is now a highway patrolman in California and a very squared away kid.) I remember specifically a couple of months prior telling him to take all the tape off the spoons [handles] of our smoke grenades. "Take the tape off, don't need it. It makes them mis-fire. You throw them, the spoons don't jump like they are supposed to, it gums them up." So he did, but we didn't clean them, my fault for not checking. So the sniper was smoking rounds off the top of this building, and I was trying to throw smoke to provide concealment so we can get to Rodriguez. I throw one and it doesn't go off. I throw another, it doesn't go off. Finally Lee looks at me and then takes off running across this 30 meters of open area, and I take off after him. We pulled Rodriguez out; the bullet had caught him in the back, bounced off his front plate and came back out.

Lee and I grabbed him, and at the same time Graniero was getting his guys ready to provide escort. We pulled Rodriguez out, throw him into the truck, put a pressure dressing on him, and I called up Apache—that's the guy that I trusted. He throws a UAV into the air, his little wasp or whatever it was, and Graniero said, "Sir, I am set. Are you ready?" I respond, "Roger, I am moving." And I am reporting, "I am at 29er5," [checkpoint, see Figure 3]. As I'm turning right to head west on Route Michigan, he says, "Are you there already?" Apache comes on the air and says, "I can see you but we are losing you." Well, I'm driving like 85 miles per hour down Route Michigan.

Knarr. So, you are heading towards...

Mitchell. Camp Ramadi. This guy was bleeding bad, he was in a bad way. He was huffing, with that shallow breathing, but the good thing was he wasn't frothing and it wasn't welling up. At first I was heading to Hurricane Point, because three days before they had a FST [forward surgical team] at Apache's place. But I was stupid and didn't check to see if they were still there, so when I told him, "I am coming to you," he responds, "I can't do an urgent. I can't do that here now." We couldn't call dust off, so I just kept driving.

Also, I had my thumb in his back because the pressure dressing wasn't working right and I didn't want to use quick clot. We didn't have the pads at the time. We had the dust, but they have to cut that stuff out. But I knew that we were within range, and SSG Rodriguez lived. Rodriguez kept saying, "My name is Rod." I mean I've got the trip tickets, and I am trying to flip through the book and hold pressure on him, and talk on the radio, so yeah, he made it. By the time we hit Hurricane Point, I was talking to Tarheel, 1/6 Marines. 1/6 Marines headquarters was at Hurricane Point along with the Iraqi Army unit. So yeah, I mean the guy made it.

Knarr. When you were out on these missions as the company supporting another unit within the brigade, who did you report to? What was the command relationship?

Mitchell. On this one I reported to Tarheel, 1/6 Marines, and I was reporting to everybody that would listen or help me. My battalion couldn't help me. In general, I did everything on my own when it came to operations and leached off of other task forces for help. I was never attached to anybody. The command relationship was usually TACON. [tactical control] When I showed up, if they said, "We don't owe you food or anything." My response was, "Well, I can fix that, standby." Since I used to be the brigade engineer and I knew all those folks up at the brigade, I could have a FRAGO [fragmentary order] out in 30 minutes. The biggest problem for me was just who was I reporting to? Normally, I reported to the task force I was supporting and to my battalion, and in some cases I was reporting directly to brigade.

Knarr. As you were working Qatana, what else was going on at the time?

Mitchell. As we were working on Qatana, we were running route clearance, security escort, hanging sniper screens, and all this other stuff.

Late December–early January, we were also working with TF 1-9 Infantry, LTC Chuck Ferry's unit, that had responsibility for Sofia. My battalion commander said, "We've got this lone platoon from Alpha Company, 16th Engineers attached to 1-9 infantry. They are putting in a combat outpost, and I need your experience and knowledge of how to put a combat outpost together to help this young platoon leader." So each day I would grab one gun truck from each platoon. Three trucks, three teams, and I would drive out to COP Apple and stay out there, design it, and build the combat outpost with Lieutenant Witt (see Figure 5 for map). He was a second lieutenant when he came into theater, came to me for three weeks, because that's what LTC Webster wanted to happen. He wanted platoon leaders coming to me for three weeks to gain some experience and then

he would push them out to another company. I was the only engineer commander who had a company, because the rest of them were task force engineers, they were staff officers, and they didn't control anything.

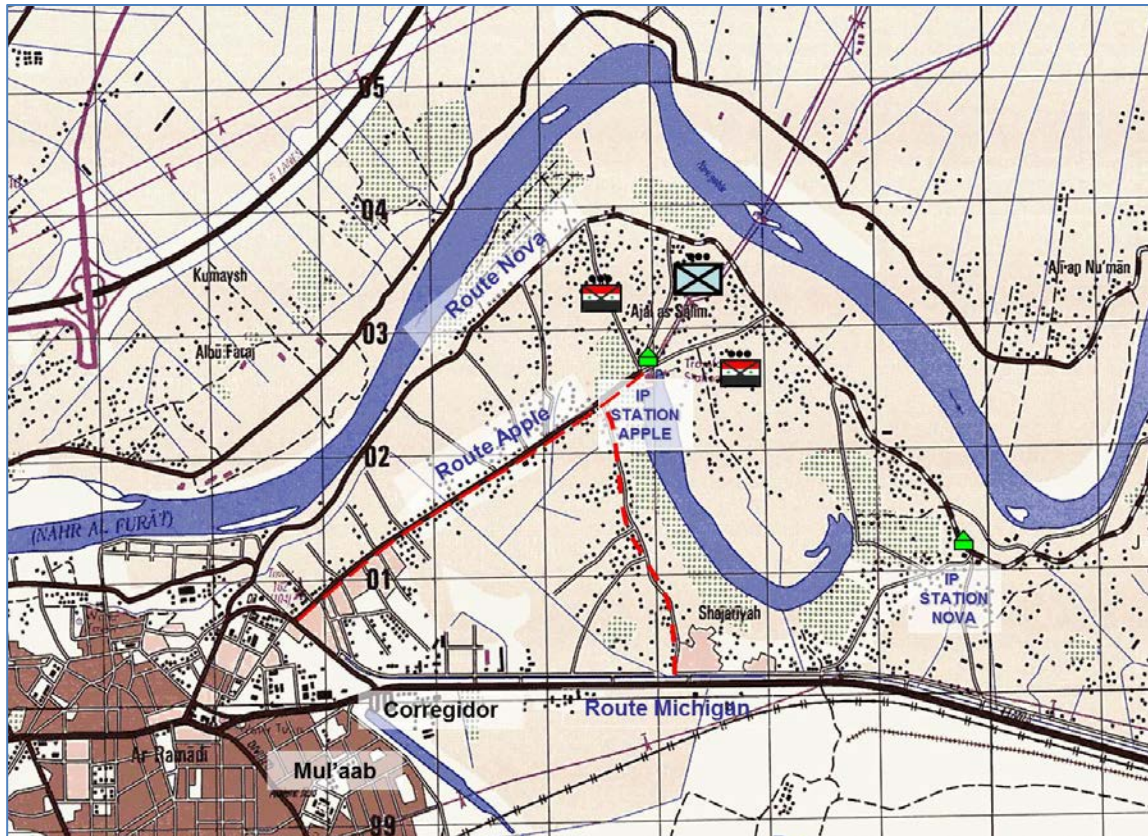

Figure 5. Building COP Apple at the IP Station

COP Apple was completely different because it was rural area. [53:55.4] We knocked down trees, just pushed them over, and then I used those like a corduroy road because of the mud. We lashed them together and used them like a road.

Some of the things I was doing, I was learning from reading old Vietnam era manuals, combat roads. Seriously, "How are we going to do this?" There's all this mud, so I was knocking down date palms, cutting the tops off, lashing them together making turning pads for tanks and other large equipment.

As we were doing this, we started taking fire. We were lying flat, [they] were shooting over our heads. It was some guys with an RPK [light machine gun] or something, but they were lighting us up. This First Sergeant and I had to get an up-armored dozer to

come out and block for us so we could get out of there. [54:46.5] I then took a couple of gun trucks out to fire up the buildings that were shooting at us.

As soon as I came back, COL McFarland showed up. Everything got quiet when he showed up. They (the enemy/locals) know who this guy is. I'm still pumped up with adrenalin and behind a barrier, and COL McFarland pulls up with his entourage. There must have been 15 vehicles with an American flag hanging on the top of ... whatever those are, the MP six-wheelers. He gets out in the intersection, and he's tall. He's 6'5" or something. He pulls up at the intersection, I'm behind this barrier drop knee, and he gets out of this vehicle like he's superman you know. I said, "Sir you have get down and get behind this barrier." He's said, "What?" I said, "I just got lit up; you need to duck." And he's like, "Okay."

That was the first time that I worked with IPs [Iraqi Police]. You don't always know what to expect. We almost killed a bunch of them because they came running down the road in these white and blue Chevy trucks with AK47s. They were loaded in the bed of the truck and wearing black leather jackets and flip flops. I've got 50 Cal [50-caliber guns] trained on them. They jump out, and I ask, "What's going on here? Do you know Sattar, Jassim?" Yeah, they know Sattar and Jassim because they are Albu-Souda. Yep, so they were okay. One of the Iraqis starts talking to me and showing me his scars. [57:25.9] He had 5.56 holes all over him. They [the IPs] were all scarred up. I just told him the guy couldn't shoot straight. That was the first time I realized that things were changing. After Travis [Patriquin] was killed, that was when I realized it.

Knarr. When did you go up to Sofia?

Mitchell. In January/February. Because they hadn't built it yet. Yeah, it was my last mission. I was running back and forth. I would go to Qatana, and then down Race Track and hit 29er6 [check point], and then pass Corregidor, and then head up to Sofia and Apple.

Knarr. So you left at the end of February, beginning of March?

Mitchell. Yeah. We worked all the way up to four days prior to flying. I had moved out of my barracks and moved into the tents, and I was still running missions all the way up until the end.

Knarr. So 3rd ID comes in. Colonel Charlton, 1st BCT Commander.

Mitchell. Yeah. I had an engineer company to RIP with. They did take over our missions there except for route clearance.

Knarr. What were some of the lessons you learned while you were there?

Mitchell. When I came in, nobody taught me the TTPs [tactics, techniques and procedures].

Nobody had an IED lane so we could walk through it. So something that I did very quickly and put one of my platoons in charge of was, “You are going to build an IED lane for the company and it’s going to be exactly what you are picking up off the streets during EOD escort and Route Clearance.” We established our own IED academy if you will, and we just called it an IED lane. I said I wanted to have something where these guys could see this before they go out. We developed a week-long training for the new guys that came in, they had to go through it. When we RIPed, we set up driver’s training for those guys—nobody had done that [before]—set up an IED lane for them, and taught classes. We didn’t want them to have to learn the same things we had to learn the hard way.

But again that was purely the company. That’s just taking the initiative to do it. The guy who came in to replace me was very good.

Specialist McPeek was our last Soldier killed, the night his platoon was supposed to come off from Falcon. They were RIPing with 3rd ID and there were two guys killed, McPeek and one soldier from 3rd ID. That was grim reminder not to let your guard down and take this place lightly.⁴

The replacement unit ended up doing okay and didn’t take as many casualties as we did. We were in the bees nest at the time, and the bees were swarming.

Knarr. Anything to add?

Mitchell. It was the greatest leadership experience of my life, that’s for sure.

⁴ Specialist Alan McPeek was killed on 2 February 2006 from small arms fire in Ramadi. He was assigned to Bravo Company, 16th Engineer Battalion.

Updated 11 January 2013

Subject: Interview with Captain Stephanie Cooper, USA, Lioness Platoon Leader, 1st Brigade Combat Team (1st BCT), 1st Armored Division (1AD)

Captain Stephanie Cooper, USA, was a member of the Legal Section, 1st BCT, 1st AD, in Iraq from January 2006 until February 2007. In June 2006, as a result of a request from one of the battalion commanders for US female soldiers to support an operation scheduled in late June, CPT Cooper developed, organized and trained the Lioness Platoon, consisting of up to 20 personnel broken down into teams. The team normally consisted of four people, two female soldiers, a medic, and an interpreter—generally all female. Those teams were used to support 1st BCT operations by segregating the women and children from the men during operations to search and questioning them. As the platoon leader, CPT Cooper's teams supported 22 operations to include Humanitarian, Cordon and Knocks, and High Value Target capture missions.

CPT Cooper was interviewed at IDA on 17 December 2010 by Dr. William Knarr, Ms. Mary Hawkins, Ms. Lauren Burns, Ms. Jennifer Goodman and Lieutenant Colonel David Graves, USMC. The following is her account of the development of the Lioness Platoon.

Dr. William Knarr: You are Captain Stephanie Cooper, US Army, and you are a JAG [Judge Advocate General] Officer?

CPT Stephanie Cooper: Yes sir.

Knarr: When did you come in the service?

Cooper: I went ROTC [Reserve Officer Training Corps] from Norwich University, so I was commissioned as a 2nd Lieutenant in May of 2001. I didn't come on to active duty until January 2005. I was in law school during that in between time.

Knarr: What was your first assignment?

Cooper: My first assignment was in Germany. I was attached to 1st BCT [Brigade Combat Team], 1st Armored Division in Friedberg. I did all the administrative law and the claims law. I did that for about six or seven months before we deployed to Iraq, originally to Tal Afar. Once I arrived there, I was doing more operational law and detainee ops along with the administrative law and claims.

Knarr: Rules of engagement, things like that?

Cooper: Absolutely!

Knarr: When did you get into Tal Afar?

Cooper: Got into Tal Afar January of '06. When we got there, there was a requirement that in order to keep detainees and send them up to the higher level, we had to get two sworn statements implicating them in an insurgency related incident. I was going on missions with a security element to Iraqi homes to get statements from them. They would bring in all the men in their patriarchal family. The men would look at the pictures of the detainees that we brought, and they would write sworn statements. Pretty much as soon as I hit the ground in Iraq I had the opportunity to get off the FOB [forward operating base] to interact and do rule of law with the Iraqi nationals.

Knarr: That's interesting. Training people on custody of information and on how to obtain statements—that must have been hard?

Cooper: It was hard. Now a lot of that training, we didn't get before we deployed. And that's just because rule of law was very basic in 2006. In most places in Iraq, we weren't at the point where we were doing rule of law, because it was still such a kinetic fight. However, in Tal Afar, we were in a different kind of atmosphere where the people were willing to work with us. We found ourselves in a situation where we could work the rule of law focus a little bit more.

Knarr: How did you come up with the Lioness concept?

Cooper: Actually, I can't take the credit. It wasn't me. Marine units were doing Lioness Teams. They were putting them out at TCPs [traffic control points].

Knarr: When you got there?

Cooper: Yes, when I got there.

Knarr: In Tal Afar?

Cooper: Not in Tal Afar, in Ramadi. Excuse me, let me go back. We moved to Ramadi in May of 2006. They moved the entire Armored Brigade down to Ramadi to take over for the Pennsylvania National Guard that was RIP'ing [relief in place] out. So, when we got there, a Marine battalion that fell under 1BCT's command and the Marine Commander, Lieutenant Colonel [William] Journey, was planning an operation at the Saddam Hussein Hospital. For the operation, he requested that now-General MacFarland, provide a Lioness Team. So this concept was completely new to our Brigade. I didn't even know what

a Lioness Team was. LtCol Journey explained that this was basically female servicemember teams that Marines were using at traffic control points. Now as far as I know, Marines weren't sending these women out on missions, but they were using them on TCPs.

Knarr: So, I assume that the Pennsylvania National Guard managed the program, because Journey knew about that?

Cooper: No. I think LtCol Journey just heard about it through other Marine units in the area, but the Pennsylvania National Guard was doing nothing like that. So, we were the first, I'd say Army Brigade, that attached women to infantry, armor and Marine units to assist on combat missions.

Knarr: You mentioned that the Marines had already used them for traffic control points. Was it within the brigade area there?

Cooper: No, it was somewhere else, and I think LtCol Journey, through conversation with his counterparts in different areas of Iraq heard about this concept, and he wanted to [implement it]. I never spoke with him about it, so I am speculating. But you can see how a Lioness Team would be very useful in a hospital environment. It's very likely that you're going to run into pregnant woman, injured woman and children and that would likely be the first place insurgents would hide the weapons, the cell phones, or the money. So, I can understand how LtCol Journey would think it would be beneficial to have a team of women go on that mission with his Marines. [5:54]

Knarr: How soon after you arrived in Ramadi did this request come in?

Cooper: Well, it was probably the end of June. So we arrived in Ramadi in mid-May, and it was about the end of June that the request came in. The mission took place in early July. Honestly, I just happened to be sitting in a meeting. I wasn't the Brigade Judge Advocate, I was the second attorney on the Brigade team and a more senior JAG lead our office. I just happened to be sitting in this meeting when I heard LtCol Journey make this request. So, immediately after the meeting, I went up to General MacFarland, and I said, "Sir, if you're going to follow through with this request, I would like to lead the team." He was willing to hand it over to me.

Knarr: That's great, how did you do it?

Cooper: Well, for one thing, I had a fantastic NCO [non-commissioned officer], then Sergeant Holt, now Staff Sergeant Weaver, working with me as a paralegal. I went to her first and I said, "Would you do this with me?" I knew I was going to need NCO support, and I

was going to need her to help me with a lot of the training and preparation in putting a team together. So the first thing I did was I went to her and I asked, "Would you volunteer to be the NCOIC [Non-Commissioned Officer in Charge] of this team?" And she eagerly volunteered for it. To build the team, we sent out a mission support order (MSO) and we basically targeted different battalions that we knew had women to provide to support this team. We also asked for interpreters. Luckily, as a deployed JAG [judge advocate general], I had access to two interpreters for claims missions, and they both happened to be female. So that worked out well since I could just use my own interpreters. We also brought along a couple female medics that we got through the aid station. So, that's how we put together the original team.

As for training, we had an MP [military police] unit with us that Captain Craig Giancaterino commanded. I asked for assistance from CPT Giancaterino and the women on his MP unit. Essentially, I said, "Look, we've received basic soldier skill training, but we haven't received any specific training on searching Iraqi females or on the different things we're going to need to know when we're out there with a combat unit." So a couple of the NCO women on the MP Company put together a quick training program. We got the initial group of women together and we ran some drills.

Knarr: Did you put together an SOP [standard operating procedures] or anything like that then?

Cooper: No we didn't. You know, honestly, I didn't know it was going to take off. I thought this was only going to be one mission and I was excited to be involved in it. As a JAG you don't get platoon leader time. So to me this was like my platoon leader time, and I was anxious to make it work well, make sure the women had the training and gear that they need, and be successful when we were out there. More than that, I think what I was mostly concerned with, was that this team became an asset and not a liability. Because going out there, I would think that any all-male Marine unit, infantry unit, or armor unit, is going to think carrying a team of women is a liability. So my primary concern was to make sure we were an asset. [9:41]

Knarr: What did training consist of?

Cooper: The training consisted of how to conduct a thorough search: how to do a search of an Iraqi female, where to look for things that they were hiding, and a lot of how to do security during the searches.

Knarr: So the MPs took you through that type of training, the stacking on a door and who moves in first, so you were familiar with that?

Cooper: We were familiar with that, we talked about that in very general terms, but most of the training we received was just: here's how you search a female, here's how you pull security while someone else is searching a female. I mean, we did talk about stacking, how to enter a room, and how to clear a room, but a majority of it was very basic.

Knarr: I think what's interesting about this is since you're a lawyer you were also worried about sensitive or tactical site exploitation...

Cooper: Right!

Knarr: Tactical site exploitation, so as you go in, it's not only the searching females and segregation, but it's also custody of information, how you pick it up, how you tag it, witness statements, because you have interpreters there. That's kind of neat.

Cooper: Also, it turned into a level of negotiation with the Iraqi women—the Host National Females—because nobody had engaged them yet. Nobody had spoken with them yet. Our male soldiers weren't allowed to really speak with them, so nobody had come to them and asked them any questions. They had never really talked with an American woman. So, there was a curiosity element that led to conversation, which led to information gathering, which in some cases led to prime information that helped in an upcoming mission or that was just good to know when we planned other operations.

Knarr: Examples of different operations you went on?

Cooper: The Lioness Team ended up going on about 22 missions.

Knarr: During your time there?

Cooper: During my time there. So, from May of 2006 until about February of 2007 we went on about 22 missions. Now some of those were more humanitarian oriented. We went on a couple missions with the Dam Security Unit [DSU] that was in Ramadi, which was a Marine unit that had boats in the Euphrates. They were called SURCs – Small Unit Riverine Craft. [Figure 1].



Figure 1. Small Marine Rivercraft used by the Dam Security Unit on the Euphrates

So, we would travel via the SURCs with the Marine units to some more austere areas that Americans hadn't really visited before to conduct humanitarian engagements. We'd get out on the ground. We would talk with the locals, and we would find out what they needed. We brought a medic out. We brought a doctor out once. We brought candy for the kids, it was in line with the hearts and minds mission [Figure 2].

However, on the flip side, the hospital mission was a big one. We participated in a couple targeting missions, going after a specific high value target when it was likely his family would be present consisting of his wife and children. There was one mission when we flew in at night via Blackhawk and had to use night vision goggles on the mission. You know everybody trains with them, but in a mission, they're not that easy to use!



Figure 2. Humanitarian Mission Support

After landing in team, we had to walk about a click [kilometer] to the target house. We were wearing night vision goggles and the terrain was uneven. Your perspective was off a bit due to goggles and so there were some falls. Not only myself, but there were other male soldiers that would fall too. We were basically doing summersaults, because you're not expecting that drop, so when you fall, you would flip over due to the extra body weight you carried with your armor and your weapon. The good thing about that was at least I could say afterwards, "Well it wasn't just the Lioness Team doing falling, I saw male soldiers doing that too!" We had a successful mission that night, capturing our target with no injuries or casualties, and we were taken off the objective via SURCs. It was a very memorable mission. We also did a lot of cordon and knock missions where we'd go in and search houses and search the women and just try to see what was going on in different neighborhoods. [14:51]

Knarr: When you talk about 22 missions, how many people would go on a mission? What was a Lioness Team?

Cooper: A Lioness Team was generally two female soldiers and a medic, and if we could spare it, an interpreter. Now, we'd go out in those teams, but there would be three or four teams

going out for each mission, generally a team attached to each Company –size element. Sometimes I recommended that the battalion commander or the company commander request Lioness support, because as the JAG, I was present during the mission briefings to the Commander, General MacFarland. So, if I heard about a mission that would likely involve Iraqi women and children around the objective, I would make a recommendation for Lioness support. Initially, the battalion commanders didn't even know about these teams. So, sometimes I would interject myself and my team into these missions. That was more at the beginning. Once we got closer to the end of the deployment, what I saw as success was when the battalion commanders and company commanders in their mission planning were requesting a Lioness Team. So to me that's success. To me that shows that we proved ourselves an asset; the combat units wanted a Lioness team with them, opposed to being forced upon them just for cultural sensitivity purposes.

Knarr: How many people did you have qualified all together?

Cooper: I would say we had about 20 women. When we started, we had more, but, as I said, we didn't have specific training prior to our missions. The first couple times, none of the women on these teams really knew what we were going to be doing. So the basic soldier skills training we had was enough, but we could have used much more training. So because of that, in the initial mission we just asked for volunteers. That didn't work out so well. I mean, it worked out alright for that mission. I'd say that was an easier mission, because there wasn't as many moving pieces. We didn't have to carry as much gear, we weren't walking long distances, and it wasn't a long op. Some of the longer ops that we went on—18–20-hour ops—were more difficult. We learned certain women just couldn't handle it. So women were cut from the team. If they couldn't pack their own gear, if they couldn't carry their own gear, if they fell asleep while we were out there, if they did anything that really set us apart and made us look bad, then they were immediately cut and they were never taken out on another mission. So because of that, I guess you could call it, initiation process, many women were cut and we ended up with a team of about 20 women that really knew what they were doing and had the capabilities and drive to do well.

Knarr: What was the first mission? Was it the one for Journey?

Cooper: It was.

Knarr: Was it simple? Difficult?

Cooper: I wouldn't say it was simple. I would say that it was not as difficult as some of the other missions we went on. This is a better way to put it, it wasn't as physically strenuous as other missions we went on. It was the first mission, so I think all of us were a little nervous, not quite sure what we were getting into. And we really didn't know what we were going to find at the hospital. I mean it could have gone two different ways. If we faced significant opposition at the hospital, it could have turned into a dangerous mission very quickly. But overall, we weren't walking long distances, we weren't carrying heavy gear, we weren't planning to stay out for two or three days, so it was not as physically or mentally strenuous. But the unknown was what was difficult for us. We didn't really know what we were going to see, what to expect. It was our first time out.

Knarr: What units did you support? I mean 1/6 Marines of course, with Bill Journey.

Cooper: Right. We supported 1-6 Infantry, 1-37 Armor and 1-35 Armor. I would say that by the end of our deployment, we had been on a mission with every combat unit in Ramadi. [19:56]

Knarr: You talked about a team of two and a medic and potentially an interpreter. How many teams would normally go on a mission?

Cooper: It was very mission dependant. I mean if it was a company-size mission, then we'd generally just send one team. For the bigger missions, company plus to battalion size, it could be anything from two to four teams. A lot of the cordon and knocks, we sent more teams, because the unit was more spread out, so it was better to have a couple women with each different element as opposed to having one team. We've done it both ways. We did it in ways where we sent one female team, and they just hung back in a central area. Then when the men went into houses and found women, they'd call back for the team and the women would move up and go into the house. Personally, I don't think that worked out as well. It burned time having to send for the women, having to get them up there. It didn't allow for beneficial site exploitation with the Iraqi women, because we went there, we searched them, and we left. Whereas if we were with the men going through each house, whether there were women there or not, we found that the male Iraqis would be effected by the fact that there were females in the unit. First, the Iraqi men may be a bit more willing to talk to us due to the curiosity factor. They were interested, which led to more conversation, which lead to more information gathering on site. Second, sometimes the Iraqi men would be a bit less hostile when females were present.

Knarr: The contributions of the teams seem obvious, but how do you quantify that? You knew you made a difference, but other than just a gut feeling, were there things that happened where you said, “Clearly if we weren’t there this wouldn’t have happened or clearly when we were there this did happen?”

Cooper: There were a couple of situations where we found things on the women that seemed to be significant. There are two perspectives. There’s the larger perspective and the smaller. In the smaller perspective, many of those missions we went on we found things: we found weapons they weren’t supposed to have, we found cell phones that we later exploited, we found large quantities of money that led to questioning that maybe took them down an avenue where we found out more about the insurgents in the families. So in that aspect, I think just the things we found on these women allowed for an increased level of questioning by the interrogators once we detained these people. I also think in talking to the Iraqi women, we were able to engage them and bring them in a little bit, in a way that they hadn’t been brought in before. Sometimes we would go into a room with the women, take off our headgear, and just talk with them one on one, because we had female interpreters so we could go in there alone. All the women on the team felt safe. We all knew each other. We trusted each other. We had our own security detail essentially. So we would engage these women and get information that we would then turn over to the soldiers we were working with or interrogators back at the base that they could use. So in that aspect, we did see progress.

In a larger perspective, these Lioness teams set a new standard for military units. We became an asset when battalion commanders were requesting us. It was the higher level commanders who saw a beneficial effect. Even General MacFarland would sometimes integrate us into a mission showing his support of this new concept of female search teams on combat missions. Even now, I see that different agencies within the Army and within other branches are creating these female engagement teams and providing them significant training to prepare them for these missions. We never received this kind of training, but we still accomplished the mission. That proves to me that there is something to this. We did it just kind of make-shift from what we had available, but we were going out and doing it. And it must have been successful since now they’re fielding the same teams to go out and do exactly what we did, with much better training.

Knarr: MOS [military occupational specialty]...I assume they had all different types of MOS, cooks, medics, etc. [24:50]

Cooper: Yeah, I mean in an armor unit there are not very many women. The women you do find are the cooks, the medics, a lot of logistics, a couple engineers, so it was a wide variety. And also interesting was that the OIC and the NCOIC were both in the JAG Corp, because generally you wouldn't think of lawyers had any place in combat missions. But, this was another very good reason to have me out there; I could give on-the-ground advice to the commanders on rules of engagement. I was very aware of the fact that all I did was give advice. The commanders are the ones that make the decisions. All I do is advise them. And so I think that helped, because I wasn't out there with my lawyer hat on trying to tell them you can't shoot at that. I was out there to say, "Well, you know here's hostile intent. Here's a quick review of hostile intent. I think we've got it here. Your call, Sir." So it provided a different aspect for those commanders, especially some of the battalion commanders that don't have their own lawyer. In the Army, JAGs are assigned only down to brigade level, so allowing a JAG to go out on these missions with company commanders and battalion commanders made these commanders feel that they had their own JAG. A JAG that was readily accessible, on the ground with them, assessing the situation. I mean in the heat of the fight, there is no time for an analytical discussion on ROE, but prior to the fight, they had a lawyer next to them to help assess the situation.

Knarr: That is good. PID [positive identification]?

Cooper: Right.

Knarr: Likely identifiable threats, etc. Yes, I can see that.

Cooper: The reasonable certainty that comes with hostile intent was the difficult piece because it is very situation dependant.

Knarr: That's right, and proportionality.

Cooper: Right! Those are all questions that you know we try to train our soldiers on, very succinctly prior to deployment, but when it comes down to it, it's difficult. You are using your own discretion to answer those questions, and it's difficult. So if you have a good lawyer there I think you can help your commanders better understand the situation and you get away from some of that skittishness around the ROE.

Knarr: Did you sit on the targeting boards?

Cooper: Yes I did.

Knarr: Boy, you've got some experience!

Cooper: I sure did. I'm afraid no deployment will ever be as good.

Knarr: So the first time you heard about Lioness is when Bill Jurney brought it up?

Cooper: Right.

Knarr: See that's where the lessons learned process should be picking that up. I mean, it started in 2003 with Brinkley and the 1st Combat Engineer Battalion that was first with the 82nd then the 1st MARDIV [Marine Division] came in later, and I guess they were under them. I would have hoped that the lessons learned process would have picked that up and put it out so you're not hearing it for the first time.

Cooper: Right. Well I think, without getting too deeply into the issue, part of the issue is with the Combat Exclusion Policy, units were unsure of where the line was. [They were] unsure of how far women could go. So, what's that old phrase? "It's better to ask for forgiveness than ask for permission."

Knarr: You could be right, some of them might just say no.

Cooper: Right. So I think female servicemember involvement in combat missions was kept quiet at the ground level. I believe units were doing it, but would rather not talk about it, because they weren't sure what the line was.

Knarr: Where is that now? I am sure you've probably followed that since then. You talked about the PBS special, which has been out for a while. Do you know what the status is now?

Cooper: Well, congress did set up a team to look into the Combat Exclusion Policy and determine whether changes need to be made. They issued a working report, I think, the end of December. I haven't actually reviewed it yet, but it is something that is under review. They are considering what are the left and right limits especially in a fight where there's no front line. You know, everything's the front line. How far are we going to let women go? And on the other side, how far have women already gone? And is our society ready for women to go as far as they've gone?

Knarr: In February 2007, you were ready to leave. You have your RIP/TOA with 3rd ID with Charlton. Did you pass this on? Did they pick it up? [29:44]

Cooper: We tried hard to pass it on. I thought this was a program that needed to be sustained, especially after we left. Ramadi was much improved by the time we re-deployed and in my opinion, that made the Lioness Teams even more important as Rule of Law and Hu-

manitarian missions became more prevalent. Although there was less kinetic fighting than when we arrived, the negotiation, the information gathering, and the site exploitation of the females in the area could still provide essential information to the new Brigade as they worked on stabilization of Ramadi. In GEN McFarland's, "Clear, Hold, Build" campaign, we were at the build phase - I thought it was imperative that we get the Iraqi women involved in this. We held a women's engagement prior to our departure where we Sheikh Sattar's wife and other Iraqi women attended. We talked to them about how Ramadi was changing, how they could have a bigger part in the change, and what kind of change they wanted to see. Conversations like that needed to take place with those women, so they could be a part of the change in government. If they had a stake in it, they would help push for changes rather than sitting on the sidelines. This was a novel idea, getting the Iraqi females involved, but in helping to rebuild the country, their involvement could have a significant effect.

When 3ID arrived, we did train one of their female Captains in that unit who worked in the S3 section. She came out on missions with us, and I gave her everything I had. I talked to her in-depth about the program. We pulled in all the women from their headquarters company, myself and my NCOIC did a brief with them. We explained what the Lioness Team was, provided them pictures, talked to them about missions, and training. We also took a couple of the women out on one of our last missions in February. The motivating story coming out of that mission shows the dedication of my NCOIC. SSG Weaver was manifested to re-deploy that very night. I said to her, "You know, maybe you don't want to go on this mission. You know, just to be safe." She responded, "No! Absolutely I am going on this mission. This is my last mission as the NCOIC of the Lioness Team. My team will not go without me."

Knarr: What happened? Do you know?

Cooper: I don't know for a fact, but I kept in touch with the captain that I had turned over the program to. I think they went on a couple missions, but the program eventually died out in Ramadi.

Knarr: Now, what was her MOS?

Cooper: I can't remember.

Knarr: Did you ever have anyone hurt?

Cooper: No. We didn't have anyone hurt. We had injuries, but not combat injuries. So no, I'd say we didn't have anyone hurt.

Knarr: What about Combat Action Badge? I assumed you were authorized them.

Cooper: Right, we were authorized them. None of the Lioness team women were in a situation that warranted a CAB.

LtCol David Graves: When you redeployed to Germany were you able to continue to develop the program or did it kind of die?

Cooper: When I returned, I went into a more legal-centric job and for the most part, I left the program in Iraq. A couple months later, a good friend, then Command Sergeant Tim Strong, got in touch with me to welcome me back and to talk to me about my deployment. Most of his time had been in the SOF [Special Operations Forces] community, so he was really interested in the Lioness Teams, because of things he had seen and experiences while he was deployed. So he said to me, "You know Stephanie, you really need to write an AAR [after action report]. You really need to write down the things that worked and the things that didn't work."

He had a better perspective on the direction the Army would be going. He foresaw that these female engagement teams were going to be established and sent out in the future. So, because of my conversation with him, I put together an AAR, and I sent it to him. And then it got me thinking that maybe this needs to go further. Maybe we need more information like this out there so that the next teams, if they do decide to make these teams, the next one will receive the training that we didn't receive. And also, maybe, not the publicity, but the knowledge that it's out there by battalion commanders and by company commanders planning missions. I mean, everyone in our brigade knew about it, because I made sure to inject us where I thought we needed to be. But outside of Ramadi, outside of our brigade, I'm not sure how many people knew this was an option. We had to be careful, because even I as a lawyer wasn't sure how far we could go under the Combat Exclusion Policy.

Knarr: Now you said you put out an AAR, and you said that you thought it had to go further. Did you then write something beyond the AAR? [35:35]

Cooper: I continued to add to the AAR and sent it to my NCOIC for her review and assistance in providing a full picture. I made sure it was a good product and forwarded it on to CSM Strong for his review. He, in turn, passed it on to members of the SOF community

as they considered establishing these female engagement teams. Since then, I have been called to answer additional questions that go beyond the scope of my AAR, to include what kind of training is needed and how could you have made these teams better. That's encouraging to me, because it shows that we are entering a phase where these female engagement teams may be given the opportunity to play an important role in establishing a new Afghanistan and a new Iraq. It really makes a big difference when you have female soldiers out there for both kinetic and non-kinetic operations.

Knarr: Can we get a copy of the AAR?

Cooper: Sure.

Ms. Lauren Burns: Do you know exactly what the SOF teams are thinking about doing at this point in time?

Cooper: No, I am not sure.

Burns: Have you seen the training that's going on down in Fort Leavenworth for some of the female teams at all?

Cooper: No, I haven't.

Ms. Mary Hawkins: I think it's interesting that you had interaction with Sheikh Sattar's wife and some of the other women. What were their perspectives? What were their worries?

Cooper: Well, I can say they were much stronger than I thought they would be. I guess because a lot of us have a misperception of the Iraqi women being subservient to her husband, silent, humble and irrelevant. I figured they wouldn't really have much of an opinion on their own. But these women were a lot stronger than we gave them credit for. They had strong opinions on what their country needed. They wanted to be involved in the rebuilding. Some of these women wanted to be a part of the Iraqi police force, which was a shocking realization to me at that time. In the same way our Lioness teams were breaking down barriers and assisting combat units on these missions, the Iraqi women wanted to break down barriers and help provide security for their country. We weren't so different. The Iraqi women felt encouraged to see female soldiers. Likewise, our female soldiers felt encouraged to meet these strong and determined Iraqi women. They knew what they needed, they knew what their families needed, they knew what their country needed and it was interesting to hear their concerns. They had never been asked before.

Many of their concerns were medical based—“How do we get the treatment we need? We don’t get much treatment here. We don’t have good doctors. Our kids are sick. Can you treat our kids?” A lot of what they needed, or wanted, they expected us to provide, which is understandable. I mean, we were there and we were offering help, so they’re going to ask for help. And they were very willing to ask for our help. We were able to help them in some cases, not every case, but I brought around my green book, and I wrote down everything they needed. I told them, “We’ll do what we can.” And then there is a requirement to get back to them – this keeps the lines of communication open.

Now the difficulty with that was, it’s one thing to hold this women’s engagement and have all the women come and talk. But after that it takes a lot of planning: tracking down some of these women again, and getting a security element from the brigade to take us out to meet these women did offer some logistical problems. I think logistics was one of the main issues with humanitarian focused Lioness team missions. We could have done more if we had a designated security element. However, keep in mind, for most of our deployment we were in a very kinetic fight so the humanitarian missions really didn’t pick up until the end. Now having said that, General MacFarland definitely supported us. He only had one MP Company, that worked as his PSD [Personnel Security Detachment], but he allowed his MP Company to take us out on some of these missions. So he offered that up to us, and we took advantage of it when we could.

Hawkins: Are there any specific stories that stand out in your head of any of the missions?
[40:01]

Cooper: You know that was really the hospital mission. And there are a couple of different reasons, some personal and some not. It was the first mission. In ROTC, we trained as platoon leaders, so we train to go out and do these kind of missions. But I knew fairly well as a JAG officer, I was never going to do these missions. I was going into Saddam Hussein Hospital. It was July 4th, and because LtCol Journey is from Boston (I believe he’s from Boston), he named the objective that we were going to take “Objective Fenway.” I’m also from Boston, and I’m a huge Red Sox fan. I thought, “This is fate! I am meant to be here, at this moment, for this operation.” So that was kind of my defining moment. That was the moment that I thought, “Wow, this is incredible!”

[It was also incredible], because it was the first mission and there were so many unknowns. Not only myself, but all the women on my team were willing to accept that. We were willing to say, “Yeah, we don’t know what’s going to happen when those doors get

blown open, and we go in. We have no idea, but you know what, we're here. We're going to support it, and we're going to do every single thing that our male soldiers are going to do." When we went in, it was intriguing to see some of the things in the hospital and to meet some of the people in the hospital. We found certain things. We found weapons, money, and cell phones that the women were hiding, which lent credibility to needing us there. I also remember we found these weird little bottles filled with what was translated to us as liquid steroids. And so we thought that was interesting and that kind of led us to believe that it had something to do with pumping up the insurgents before they went out to fight. [See Figure 3].



Figure 3. A Lioness Team present during a Hospital Mission

Although this was my most memorable mission, every mission we went on taught me something new. If it was just a lesson learned for how to run my team in the future or whether it was something more personal that showed me that I was strong enough to do this. Or it re-emphasized in my head that this was the right thing, and that it was good that I was forcing us out there, because it was beneficial. You know? I do remember one

mission that was a cordon and knock where we blocked off this whole area. There were tanks set up blocking off the area, and they didn't want to move us forward, so they kept Lioness Teams in the Bradleys. Me and another paralegal and my interpreter sat in a Bradley for 12 hours and froze to death. It was boring and certainly not the best use for our teams, but, I'll tell you this, I learned a lot about Bradleys that night. The gunner and the driver in charge of the Bradley were experts and we were open to learning. I said, "Hey look, this is great opportunity for professional development. We're stuck here and nothing's going on, so why don't you show us how this Bradley works." So, we got something out of every mission even if it was outside what we expected.

Knarr: That's great!

Ms. Jennifer Goodman: You talk about training, and you didn't have very much. You had a very minimal amount. If you were to go in and teach one key element to future Lioness Teams or programs, what would that key element be? Because I see a lot in your own personality, a quality trait of "This is important, this is going to be a part of this mission" and you interjected it often, according to your statement. Do you think it died off with Charlton's group because someone didn't have that "this is important" personality?

Cooper: Possibly. I can't really speak too much on their rationale or mission focus. Ramadi was a different fight for them than it was for us. They had a lot of success in Ramadi doing things their way. Going to your question on what I would train, I think there are two aspects that are most important for these women to be trained on. The first one is physical training. These women need to be able to handle it. They need to be able to carry their own gear. They need to be able to march 12 miles. They need to not complain, not whine, and do it, because that's what the male counterparts are doing.

Second, they need more than basic soldier skills. When you go through AIT [Advanced Individual Training], when I went through my ROTC Advance Camp, we got basic soldier skills. But first of all, that is not enough training for the missions we were going on. Specialized training with more of an MP-like focus would be extremely beneficial. Second, years later, when you're not using your basic soldier skills on a regular basis, a lot has been forgotten. Extensive refresher training on basic Soldier skills would help make it second nature to us. I can say I am very impressed with the quality of women on my team and what we were able to accomplish without that training, but I think with that training we would have been even better. [45:30]

Burns: Do you see a role for these types of teams outside of places like Iraq and Afghanistan? Whether that's in Africa or with traditional communities—do you see these teams as being a useful way to engage just in terms of rule of law and humanitarian, but also for intel gathering?

Cooper: Absolutely, I think women generally know more about what's going on, because they gossip, right? No matter what culture you're in, women are going to gossip, so they know what's going on with this woman's husband or this woman's brother or this woman's son. They all talk about it. So if you can integrate into those women's groups, and show them, "If I take my Kevlar off and take my body armor off, I'm just a woman, too. Tell me what's going on in the area?" You know, then they're more willing to talk to you and to bring you in, especially when they know you can give them something. They are happy to talk to you when they know they're going to get something out of it.

I think one thing that's most important if we do look down that road of bringing these teams to other places is the women need to know the cultural sensitivities of the area they are going to. They need to know how to best integrate themselves into these female social groups, wherever they may be. The information gathering and intel collection that these engagements may provide would be beneficial.

Knarr: I am sure you've been interviewed a number of times before, and you've probably given plenty of talks on this. What didn't I ask that you say, "Boy, I can't believe he didn't ask me that question"?

Cooper: You asked the most important questions. I want to emphasize the importance of having a strong team that could be relied on and an exceptional NCOIC. Because of my regular job as a JAG, I was unable to go on all 22 missions. But one of my favorite stories, and I am sure General MacFarland won't even remember this, is regarding a mission I wasn't planning to go on. The lead JAG, my brigade judge advocate, was home on leave and therefore I had to stay on Camp Ramadi, to ensure all the legal functions were covered, and skip a couple missions. I sent my NCOIC out, and the team was well prepared. There was one mission, Operation Yorktown, that I felt it was necessary to participate in -it was more physically strenuous. I wanted to send the message that the OIC was there for the toughest missions and motivate the female soldiers when they started getting tired and frustrated. We would be deploying four teams in two different sectors, and I thought it was imperative that strong leadership be present in both sectors, my NCOIC and myself. So, I remember going to General MacFarland and saying, "Sir, I

completely understand if you need me back here since I am the only lawyer right now on the FOB. I know that you need to be able to reach me and I understand that. But, I have to request to go out on this mission with my team. It's a 12-hour mission. I really feel I need to be there to lead the team." I expected him to think about it and say, "Well let me see what's going on. Let me get back to you on it," you know? And his response, I'll never forget it, he said, "Stephanie, Aunt Jemima pancakes wouldn't be the same without her syrup, just like the Lioness Team wouldn't be the same without you. Go on the mission" It was so unexpected from him, but his support was inspiring.

Knarr: That's the impression I got from him when I asked, "Who should I contact on the Lioness Teams?" He said your name, and he smiled, so I knew there was something very positive behind that.

Cooper: Yeah, I can honestly say that if it was not for GEN McFarland, we would have never gone as far as we did. We would have never gotten to do what we did. I'm just amazed at the way he foresaw the whole plan in Ramadi, how he saw that we could make a difference, and how he honestly trusted me and my NCOIC to make this a successful endeavor and to add to what he was already doing. You know, this really was an addition to his program. It was a way of engaging the female populous in buying into the changes that were coming. And he saw it before I did. I mean, when I heard LtCol Journey make that request I thought, "Yes. This will be an incredible opportunity. We'll get to get off the FOB. I'll get to go out there and use real soldier skills, and I won't just be reading my legal books. This will be great!" I didn't think of the long term effects until I got back, until I saw the difference we were making even towards the end. And then thinking even more on it I realized, General MacFarland being the extremely intelligent man that he is, saw the benefit of engaging the female populous from the get go. 50% of the population had been ignored up to this point, or had been disrespected according to their customs. General MacFarland saw the long term picture and saw the effect a female engagement team could have. So, his support and encouragement of these Lioness Teams going out to do this mission is really what made the difference. If your brigade commander is saying, "I recommend you take a Lioness Team out with you" to a battalion commander or a company commander, it's giving us credibility. It's giving us immense credibility! He is an extremely intelligent man and I was impressed over and over again by him.

Knarr: What else? What else would you add that I haven't asked? [51:24]

Cooper: I am trying to think if there's anything else we haven't covered. I guess I'd say there were good missions and bad missions we went on and some of the toughest thing was winning over the male counterparts who weren't used to having woman out there. That was a tough fight in a lot of cases. There were some units that I don't think we won over. I don't think they wanted us out there. And even after the mission, after we proved ourselves, I think they just didn't see a need for it. And that has a little bit to do with the old boy's society.

I'll say something very clearly here. You may think that because I am here talking about the Lioness Team, talking about women being out there, I think women should be allowed into all the different units, but I don't. I think that men need their infantry unit, they need their armor unit. I don't think women have a place in every MOS in the Army. But I think that we can be an asset as a support function that's available to go out when they need us. With the right physical endurance training, negotiation skills training, information gathering training, and basic cultural sensitivity training, I think we could make a real difference. My team did.

You know, I think female engagement teams could be a huge asset. We were an asset, but I don't think we were as big as we could have been. That's partly due to the fact that we were so new. What we were doing was so unheard of, at least in our brigade and our area. There was some skepticism initially. I don't know if we thwarted all that skepticism before we left. I know we did some of it, because like I said there were battalion commanders and company commanders asking for us to go out. There were units that requested us over and over. I mean the DSU Team we went out probably on five missions at least. And 2-37, we went out on three or four missions, so I mean, we were going out on missions over and over again with the same units.

But there were always going to be a couple of leaders and NCOs within those units that thought we had no place there. In some cases, you will never be able to overcome that presumption. In other cases, it can be overcome by proving a female engagement team is an asset and not a liability. I know I've said this over and over but it is probably the most important take away for building teams like this in the future. The only way I think you can combat that presumption is by proving you can do what your male counterparts can do. You are not going to need them to carry your stuff. You are not going to need them to fire for you. You know how to use your weapon. You know how to clear you weapon. You know how to fire your weapon.

Just proving yourself to male counterparts was one of the challenges we faced. For the most part, I think we overcame it. I mean there were problems we had with certain women that didn't do that. They didn't carry their own stuff. We had a medic that didn't want to take her full medic bag, because it was too heavy, so she brought the dumbed down version essentially that had a couple Band-Aids in it and a gauze pad. When we found out about that, I can't even explain to you without swearing how angry I was. So we did have issues. Luckily they weren't prevalent. But, that one medic that didn't bring her stuff because it was too heavy, she proved up the skepticism that male soldiers in that unit already had. That one woman did it even though there were eight more of us that went on that mission and did all the right things. All it takes is one to mess it up.



Figure 4. Cordon and Search Support from the Lioness Team

Going forward, looking at what the Army is going to do with these female engagement teams, if they decide to field them in the future, these women can't be voluntold to do this. They won't do it right, and they won't have any sort of investment in it. They don't

care if they succeed or fail. They don't see the bigger picture that they're not just representing themselves. They're not just falling out for themselves. When they fall out it makes a statement that women are falling out, woman can't handle it. So I think it's important that these teams in the future do get the training they need and do understand the bigger aspect of how important this is and how important it could be as we go forward. They are not just individuals anymore, they are representing all women in the military.

Graves: On your first mission you were requested by Colonel Jurney. After that, did you have to go out and sell this Lioness Team concept to other units or did it just pick up momentum that other people heard about and decided they wanted to start requesting?

Cooper: Oh no, I had to fight tooth and nail to get on missions. After the first mission, I saw we made a difference. On that first mission, I think it was a small difference, but I saw that we were good out there. We did something that they couldn't have done without us. So, I came back, and I back-briefed General MacFarland on it. I said, "You know, sir, I think we need to go out more often. I think we could really make a difference on some of these missions." Sitting in on targeting and op meetings, where the battalion commander was briefing the brigade commander on his plan of attack, I would interject myself and say, "You know, sir, maybe you should consider adding a Lioness Team, it could be beneficial on this mission for dealing with female Iraqis that you're sure to encounter in this home/location/building." Because General MacFarland supported me, he would second my request. He would say, "You know what, I think that's something you should Colonel so-and-so, could use a Lioness Team? It may benefit your mission." So when the brigade commander is saying, "I think it's a good idea, but it's your call," the battalion commander wouldn't feel compelled or forced into it, but in my experience he would consider it and in more cases than not, add it into his mission. Some were eager to deploy these teams, after learning about them, but not all. Some of the battalion commanders were understandably very old school and didn't think the women really belonged with them. They had been in all male units for 15 years or more, why would they need female teams on combat missions? So, at the beginning, I was working hard to change perspectives. Once we had been on enough missions and word had gotten around that we were doing a good job and we didn't need the guys to carry our stuff and shoot our rifles, then we were invited out on more missions. Towards the end, there were patrols that would go out and all of sudden we'd get a call in the legal office. One of the patrols would call and say, "Hey look. We're out here. We're in the middle of something. We need a Lioness Team now. We're sending a convoy back to get you, and we'll bring you

here. Can you be ready in 20 minutes?” That to me is a huge success. If they’re out there in the field saying, “Okay, we need, we need it now, go back and get it!” WOW. Towards the end, we were invited out. We were requested more, but in the beginning every step was a fight.

Knarr: Other questions? Who else should we talk to?

Cooper: Definitely Staff Sergeant Weaver. Yeah she is. She works at the DAIG [Department of Army Inspector General] now. She’s a court reporter for the IG’s [Inspector General] office.

Knarr: Okay, thank you very much.



Figure 5. Team Lioness, 1st Brigade Combat Team, 1st Armored division

Subject: Interview with Colonel Bill Journey, former commander, 1st Battalion, 6th Marines

Colonel Bill Journey commanded the 1st Battalion, 6th Marines (1/6) from October 2006 to April 2007 in Ramadi, Iraq. His battalion had one of the most difficult areas in Iraq, the epicenter of the Al Qaeda-proclaimed Caliphate. A video of Al Qaeda's parade in the Qatana area of Ramadi was broadcast on national news during the month Journey arrived as a signal of the challenges ahead. Col Journey's battalion diligently set up security stations starting in the western part of the city and by slowly clearing and holding, pushed Al Qaeda out of the city. While simultaneously involved in intense combat action, 1/6 built, trained, operated, and lived with a developing Iraqi police force that would assume security responsibilities for that battle space.



Colonel Journey was interviewed at his office at Joint Forces Command, Norfolk, VA, 3 March 2010 by Dr. William (Bill) Knarr. The following is a transcript of that interview.

Dr. Bill Knarr: Colonel Journey, please provide some background information, such as when you entered the Marine Corps and where you were stationed.

Colonel Bill Journey: I enlisted in the Marine Corps as an 0311 [infantry] and then pursued opportunities to the enlisted commissioning program from there. First duty station was in Guam on barracks duty.

Knarr: I understand you took command of 1/6 Marines in October 2004 and deployed to Fallujah in 2005. Can you talk about that deployment and some of the lessons you carried into Ramadi in 2006?

Journey: The battalion's first deployment was to Fallujah. We deployed in March of '05 and we were there for six months [until October 2005]; predominantly responsible for the northern half of the city, which extended out to Saqlawiyah at that time, so we were post-Al Fajr when we joined. Our employment concept at that time was to establish and maintain a permanent presence within the city, so we immediately moved into fixed sites throughout the city. Within the first 30 days, we pushed out to Saqlawiyah, a small rural

area, in order to improve the security of the city. Kind of like initially defending the hockey goal from the net, we then pushed forces out further to Saqlawiyah. We had indications that the enemy was forming and operating from that area.

Within that first 30 days, we seized a key building using one company in which we could establish a permanent presence just outside the city. That was conducted with one of our partnered Iraqi battalions. Right away we had Marine and Iraqi soldiers eating, sleeping, living together, and filling sand bags, in order to defend themselves from that position. Soon thereafter, we were able to interact and meet with the local government structure that we had stood up. Right away you see a typical COIN [counterinsurgency] experience where a company commander is operating with a local village council. Soon thereafter, we started standing up a local police force. Again, with the limitations of police transition teams, we took people out of hide at that point and that particular company XO lived full time with a group of NCOs in that particular police station.

Some of those experiences were obviously techniques and concepts that were utilized when we went to Ramadi. At that stage of Fallujah, the predominant focus was on the Iraqi Army. There were the Public Order battalions, which were sort of paramilitary forces. So those were the Iraqi organizations that we were partnered with.

Operating as a combined action battalion, we were not operating just a stand-alone, military transition team [MiTT], but the battalion was fully partnered and working with the Iraqis as one team. In March of '05 that was our concept of operations. Later we expanded our operations to include all the entry control points and the mechanisms for interacting with the public and opportunities to provide vital information to the public as procedures evolved and improvements occurred.

So those were some of the aspects of our deployment to Fallujah which played heavily into our employment concepts that we utilized in Ramadi.

Knarr: This term “Combined Action Battalion” [CAB]—that really came out of Fallujah with you then? Is that correct?

Jurney: Correct. That was not a new concept. We obviously learned from the lessons of our combined action platoon (CAP) employment concepts from Vietnam. We saw the military transition team’s mission exceeded the capability of the eight or nine guys assigned and that effective partnering really called for the employment of a CAB, the battalion partnering with the Iraqi battalion to include platoon leaders partnering with platoon

leaders and noncommissioned officers (NCOs) with NCOs, with the focus being to stand up and improve the capabilities of those Iraqi battalions.

We didn't focus on running a boot camp-style training, but emphasized employment and fundamental security operations. Now, to augment the employment piece of those battalions, we placed a Marine squad and an Iraqi squad right alongside each other. They go through the same pre-employment combat checks, preparations, and issuing of orders. Likewise, if you're doing cordon and searches or knocks, the Marines and Iraqis have to start at the beginning so that they're partnered fully through the whole process. I was partnered at the brigade and battalion as were my company commanders at the company level, and then we grew that capacity. Over time, our objective was to shift the relationship from supported to supporting. Initially it's the young Marine sergeant who leads the patrol while the Iraqi unit supports him, but the training is still occurring as part of the employment—not talking about it, not teaching a class, but doing it.

Eventually, the Iraqis would start mimicking our Marine units, doing the techniques, tactics, and procedures (TTPs) the Marines were using. The purpose was to grow the ability of each Iraq unit, so that over time, the roles of supported and supporting would switch. This was our measure of success. We wanted to get to the stage where the Iraqi battalion commander, for example, understands that he is the lead on a cordon and search. He comes up with the plan and I support him. We worked together in kind of a consensus fashion in order to make sure that all the right parameters were being met to successfully accomplish the mission and safeguard the force. But that's the direction you're moving, and it has to be more intuitive than some check list that says, "They have done four patrols so now they should take the lead on the next patrol." That's not necessarily true. You have to be on the ground with them, measuring their ability on a day-to-day basis because you want to set them up for success. You don't want to over extend a young developing unit, no more than you would a young developing Marine NCO. So, all those things are taken into account as you look at different mission sets and the Iraqi transition to a leading role and us supporting them. We learned some valuable lesson as we moved along with that piece of it.

So when you talk about training Iraqi Security Forces, be it army or police, in our minds' eye the focus was on employment, and developing their capacity in such a way that the supported and supporting relationship shifts to the host nation, the Iraqi Security Force element. Then you still want to stay engaged. You don't want to completely decouple

with them, because there's a certain quality control piece that you want to maintain, and you want to ensure they are still progressing, still developing.

There were a couple of additional things in Fallujah that we also employed because it was a very formative period for those newly-formed Iraqi security forces, post-Al Fajr, and that was developing the Iraq junior leadership through a junior leader NCO course. We put together a permanent cadre of personnel from within the battalion, under the Marine Gunner, who set up a permanent training facility. Each of those Iraqi battalions nominated a certain number of personnel who would attend a ten-day long course, which focused on the employment of the basic skill sets such as shoot, move, and communicate-type skill sets; nothing varsity level or over the top.

We then had formal graduations, in which I would have the Iraqi brigade commander and battalion commanders deliver a graduation speech and shake everybody's hand. So you are building relationships and trust along multiple lines in that respect. Likewise, we employed mobile training teams to partner along different functional lines such as logistics, communications, and intelligence. Again, as you look at a combined action battalion, I'm looking at my battalion operations officer, my intelligence officer to develop that Iraqi battalion's capability. So we understood it required much more than the employment of the MiTT to develop the Iraqi units. Those are some of the aspects of our deployment to Fallujah that weighed heavily into Ramadi. [11:00]

Knarr: I am interested in the influence of Kosovo; what did you do in Kosovo? What threads did you draw from Kosovo to Fallujah to Ramadi?

Jurney: In '99, I had the good fortune of serving as the 3rd Battalion 8th Marines' Battalion Landing Team (BLT) operations officer. The commander was Bruce Gandy. As part of the initial entry forces into Kosovo with the 26th MEU [Marine Expeditionary Unit], once we conducted cross border ops, we moved into the city of Gnjilane. Again, this was an urban experience in a city of about 120,000 folks. At that point, during the peace enforcement phase, we were on the heels of the Serbs as they were withdrawing. We were basically faced with a city of people with some strong feelings about each other, and in that sense, the enemy was anybody with a weapon. We were trying to keep the peace. Critical to stability and peace was that you somehow have to bring back a structure for the civilian community. In order to do that, the employment concept the battalion commander and MEU commander used was a widely dispersed, decentralized approach.

Very similar to what you saw in Fallujah and other COIN operations; nothing new from our small wars manual. We had rifle companies, an artillery battery that became a provisional security unit, a weapons company that assumed the role as a provisional security unit. We had over five company sectors, widely dispersed over the AO [Area of Operations], which included a large populated area in which our forces moved in full time. We further subdivided into platoon sectors. In essence, you had platoon commanders who were coordinating with local mayors and folks who were moving back to the area, restoring civil infrastructure to a certain degree, and ensuring security in those areas. This type of decentralized, dispersed, permanent, persistent presence is the only real security and the only potential for any trust with the local population that you're going to gain.

Obviously, valuable lessons were learned in terms of having a good place to operate from, what types of structures support that, what type of force protection, what type of interactions, who do you reach out to, and how do you develop your own intelligence and situation awareness? It's the people, stupid! You can't be offset from the people and know what's going on. The people know what's going on in your AO, and you have to be there 24/7. [14:22]

So that was the employment concept used in Kosovo. Fortunately for me, one of the platoon commanders on that particular deployment became my operations officer in 1st Battalion 6th Marines. So right away you had a battalion commander and an operations officer with a shared point of reference relative to urban operations in a COIN environment, which was very useful. My operations officer was a young man named Paul Maria—just a super officer, and all the credit in the world goes to him for organizing and implementing, through the company commanders, that effort, certainly in Fallujah where we had multiple lines of effort from neutralizing the enemy to improving security and stability. [15:28]

If you are there to improve security and stability, you're going to have to lower the threat to the population. Neutralizing the enemy, the tactical task that I preferred to use, whether it be hardcore folks or homegrown insurgents looking to pay the bills, can be accomplished through any number of means. That was our first line of effort. Second was to employ and train the Iraqi Security Forces; we leaned heavily on the "employ" piece of that. Third was to undertake activities along the civil-military operations [CMO] and information operations [IO] piece, for a couple of reasons: one, it's absolutely vital to providing security and stability to a population, as certain services are returning and operating to the population, if you are going to gain their trust. More importantly, we

looked at those things that also gave us a tactical advantage. Mission-essential task number one was: Neutralize the threat to security and stability. That could have been a lack of water, or a hardcore member of Al Qaeda—either one represented a threat in security and stability to us. I would submit to you that we pursued those lines of effort with equal vigilance, concurrently, not in lock step.

There is some discussion of clear, hold, and build concept. At the macro level, it is a viable way to communicate. I would submit to you that at the tactical level you can be doing all three of those things simultaneously. It's just at varying degrees. That's a key point. You may not be building, per se, a new school and a civic action project while you're still receiving fire, but that still would not preclude a commander on the ground from engaging key local leaders on what the art of the possible might be; so different degrees.

All these concepts working together was our approach in Fallujah, and we're going to talk about them again when we start talking about Ramadi. Those three lines of effort were the specific tasks that came from Colonel Mark Gurganus, who, at that time, was our regimental commander. Everybody needed to know them by rote, so they were written down, posted on the bulk head, and every young Marine knew what our three lines of effort were. Quite frankly, they worked pretty effectively in Fallujah; they made sense to me. When I was given the opportunity to take the battalion back for another deployment in Ramadi, we all had a common frame of reference of what's important to improving security and stability, neutralizing insurgents, training and employing Iraqi Security Forces, undertaking CMO and IO, which provide you a tactical advantage and reinforce the legitimacy of those Iraqi Security Forces in the local governance. We continued to capitalize on those same three things when we returned to Ramadi.

Probably one of the most significant lessons from the Fallujah experience as we headed to Ramadi was the importance of a local security force. You know, within Fallujah there was no police and it was very early and they were still developing. The police force was a developing piece and we had four basically Iraqi military organizations that we were working with, predominately Shi'a. Although they were working right alongside other Iraqis, their knowledge of the streets and providing a sense of security to the people, knowing who should be and who should not be in that city was much different from a local individual, something we learned as we developed our own indigenous reconnaissance and surveillance capabilities. As we prepared to go into Ramadi, we recognized that a local security force is the best security force if you want to have the best infor-

mation and convey a sense of security amongst the local population. To us, that would be represented by individuals from the immediate area, from those streets, and that would be in the form of a police force. [20:06]

Of course, by the time we were going to Ramadi, there was a move afoot to enlarge and develop the police force across MNF [Multi-National Force] West. That was certainly the MEF [Marine Expeditionary Force] commander's intent and focus, and I couldn't agree more, at least at the tactical level. The continued development of security forces was necessary at the MEF level, as it was at all levels. Now we have a developing military force that's continuing to improve and grow, and we have great linkages and partnerships, to include our military transition teams and the structure that support them, "Okay, how are we going to accomplish the MEF Forward's concept of developing the police?" So, when I say that was part of our combined action battalion effort—to develop the Iraqi Security Forces—I'm also talking about the police.

While we were in Fallujah, one of our efforts was to develop a reconnaissance and surveillance asset by taking individuals from across the Iraqi Army Units. We moved them onto our base, provided training, equipment, civilian clothes, various badges so that they could move in and out of the entry control points undercover. They were given specific mission sets and equipment that allowed them to identify and confirm specific intelligence requirements. [22:49] When personnel from these undercover units entered the city, however, we would have other assets within the city immediately report the presence of an enemy force. The undercover force being reported on was simply one of our Shi'a Army personnel who was undercover driving around in a civilian vehicle. Assets from within the city recognized, immediately, that that individual was not from the city. They didn't know who he was, but they knew he didn't belong in that particular neighborhood. The point is, security force has to be local.

Knarr: After returning to the United States, knowing you were going to go back, when did you get word that you were going back and when was Ramadi identified as your next area of operations?

Jurney: I was informed as I was getting off the bus on homecoming day [October 2005 from Fallujah] that I was going to be given the opportunity to remain with the battalion for next deployment. I didn't know where we were going, so exciting times from both directions: I was happy to be home and happy to be given the opportunity to remain with the

1st Battalion 6 Marines. At that point, we didn't know specifically what AO we were going to be deployed to.

Knarr: Knowing you were going to go back, you developed your pre-deployment training, planned to go to Mohave Viper, planned to do your PDSS [Pre-deployment Site Survey]. Can you discuss your pre-deployment training, the PDSS itself, the conditions in Ramadi, and how you then formulated what you were going to do when you got the battalion on the ground in Ramadi?

Jurney: Fundamentally, the focus for the training was no different than the one in Fallujah where you build a solid foundation from the squad level up. Our operations, in order to be decentralized and amongst the people, had to be built from the squad up. You didn't jump in with grandiose battalion-size plans and massive C2 [Command and Control]. If you've got strong squads, you'll have strong platoons and companies. Fundamentally, the training emphasized shoot, move, and communicate; nothing is more important than being able to hit what you shoot at. Whether you're shooting an M4, M16, a mortar or you're calling in indirect fire, you must be proficient with your primary weapon system. So across the board, we didn't cut any corners on that for a couple of reasons. Other than it's fundamental that a Marine's able to hit what he shoots at, particularly in this environment, shooting less is better. If you're trying to provide security and stability, and you hear a lot of shooting and things blowing up, it's kind of hard to communicate to a population that things are getting better. When the opportunity presents itself and you need to engage the enemy, then, if we can hit what we shoot at the first time, we're effective, efficient, and it's consistent with safe-guarding all involved, both the force and the civilian population. [27:20]

If a Marine, who's making the very difficult decision of employing his weapon, feels confident in his abilities to employ that weapon effectively and hit what he shoots at, his decision-making process is much different than an individual who lacks that confidence. An individual who lacks that confidence is probably going to think less and shoot more, unfortunately, that may not be what you're looking for in that particular situation. An individual who has confidence not only in himself, but the people to his left or right may take an extra second to discern a target's hostile intent or hostile act.

The second focus of training was being able to patrol from A to Z whether it's on foot, mechanized, or motorized. That's the fundamental basis in my mind for a squad and squad leader to be able to operate. If the squad knows how to patrol then you're going to

be able to effectively employ them in any number of attack formations, security patrols, fire support, pre-combat checks, inspections, all of which are fundamentals that everybody needs to understand. [28:56]

When you have limited time and a lot of things that everybody wants you to be able to accomplish and do well, as a commander, you've got to decide what's important. You only have so much time available, and so those are the first two things. And even for our motorized personnel, we would have them do foot patrols so that they understood how to operate away from their vehicle and become confident in that; they were employed away from their vehicles a number of times. Then they can employ and understand those tactics, techniques, and procedures whether they're working in consonance with tank, infantry, motorized ops, or dismounted forces. That was very important. [29:35]

I mentioned earlier the concept of shoot, move, and communicate. The third emphasis of our training was to understand the nature of the war that we were about to enter. Do you need to be able to work the 'trons [electrons], the radios, and other pieces of communication equipment? Absolutely! But more importantly, when I say understand the nature of the fight you're about to enter, that's the piece whereby you have to communicate to every individual in your command the need to embrace and understand the nature of the people, and the area that you're going into. Of course we had a lot of help with that from the CAOCL [Center for Advanced Operational Cultural Learning], or cultural training that was provided, and some of the survival-level Arabic skills.

I was not looking to make everybody a fluent Arabic speaker in that situation. Survival level was sufficient. It was more important for them to understand the nature of the conflict we were going into. That requires a constant framing and reframing of the situation by the leadership, from top to bottom. Everyday. What we're doing? Why we're doing it? The most important aspect of this communication is that people have to understand why you're doing what you're doing.

So shoot, move, communicate—we talked about those three things, what those three things meant; that was fundamental to our pre-deployment training plan. Now, did that involve a number of different venues from starting out with the basics, the rifle range, employing our optics, shooting both day and night, and a lot of hard work by small unit leaders who actually put the training together that met those high level objectives that I just decided? Absolutely, and more! The Training and Education Command at Twenty-nine Palms came through threefold. We were pleased with all the training we received

during Mohave Viper out at Twenty-nine Palms. The first one we went through for Fallujah was the RCAX [Revised Combined Arms Exercise], and then the piece out at March Air Force Base, was absolutely essential.

Again, foundation level of shoot, move, and communicate was to ensure that everybody understands: if we're going to employ a mortar system, we have to be able to hit what we shoot at. There's no skimping on that.

Knarr: Did you tailor Mohave Viper in a certain way to address your deployment to Ramadi?

Jurney: Absolutely not. Just because you think you're going to Ramadi so you're going to design the training specifically to your current assessment and understanding of that environment? Number one, you could be wrong on your assessment; number two, you might not go there; number three, it may change. So I voted for a more well-rounded training opportunity. You provide me with the full monty of the spectrum, let me exercise all those so that I can crawl and begin to walk, and then I'll pick up the nuances within my commander's assessment of the situation and how I think we're going to employ. Then I'll follow that up as we get nearer to where we're going and what we're going to do, which is what we did, in this particular case. After Mojave Viper, we assessed what we'd done up 'til then, where we thought our strengths and weaknesses were, and where we needed to improve. Then we designed another set of training evolutions that assessed our progress.

You mentioned the PDSS and when I went to Iraq. There are a couple schools of thought to that. Had I never been to Iraq, or never seen or understood the environment, I personally would want to go to Iraq before even going to Mohave Viper. I would need that perspective, I think, to best assess how I'm doing, and what I'm going to need after that.

In this particular case, I was fortunate because, once again, my battalion XO, my battalion ops, and one of my company commanders, had all made the Fallujah deployment along with about 50 percent of the battalion. So we felt fairly confident that we knew the fundamental baseline that we needed to achieve in pre-deployment training in order to be ready to adapt. [34:40] In that case, we wanted to do the PDSS as late as possible, so that we had the best bird's eye view of the situation on the ground before deployment. We could then refine a closer-to-ground-truth employment concept.

When you're on the ground, and you expect to be there six months, you have about a good four months that you are going to try to get something accomplished. Therefore, you need to have a deliberate plan for how you're going to move the ball forward. For

example, we're going to improve security and stability. In our particular case, we were able to not only take our company commanders and our primary staff on the PDSS, but we were now developing and collaborating with the unit in country, in real time. We were looking at their daily update briefs. I was able to communicate with their battalion commander and ask questions such as, "If you were there for three more months, what's next, what are you seeing?" So we were able to take that information and formulate our initial concept of employment back in Lejeune. [36:12]

We were fortunate in that our advance party consisted of the same key leaders. There are arguments for and against creating an advanced party of this nature, but in our particular case, our pre-deployment training was done and block leave was over. There were some final aspects of training, but nothing that our company XOs, first sergeants, and gunnies, weren't well equipped to take care of in our absence. Because of this confidence, the company commanders, myself, my OpsO [Operation Officer], Intelligence Officer, all the primaries, went forward on the advance party in order to, once again, assess the situation and develop a hard line plan for the battalion's employment. In our case, I created what I refer to as a four block plan. Basically, each block consisted of 30 days. With each of these four blocks of time we had to make a decision, create a rough outline over the next 120 days of how we were going to improve the security and stability, where we were going to be, what we were going to try to achieve, how we were going to be about accomplishing that, and who, within the organization was going to assume responsibility for each of the different parts.

In developing the plan, we had to consider the MEF Forward's overarching campaign plan, which laid out exactly where the MEF was trying to move each one of its pieces. So we were making sure that we were nested two levels up. Additionally, the brigade commander, Colonel MacFarland, Ready First Combat team, provided his plan for the particular AO—Topeka in this case. We didn't have the corner on our assessment being absolutely correct, but the first 30 days is critical. Everybody, even the enemy, knows that there's a RIP [relief in place] occurring and you don't want to lose any momentum the unit that you're replacing has generated. You don't want to lose any momentum or lines of trust that have been established with Iraqi Security Forces. So we sat down with the brigade commander the day prior to the RIP and laid out the next 30, 60, 90, 120 days. We said, "Sir, we think we're within your commander's intent, we think we're nested with the MEF Forward's way ahead here. How does this look?" He approved it,

provided me with additional guidance and tremendous support. We were the main effort for about the next three or four months.

Now, again, that required us to, every day, not every week nor every month, but every day to assess and reassess where we were and what we were going to do. That was the framework that provided a common picture for company commanders and platoon commanders to operate from. [40:14v – end of tape 1]

As we talked about the four block plan, our approach to improving security and stability in Ramadi was partnering with the Iraqi Security Forces. We were partnered with one Iraqi battalion within our area of operations. There was also one police station located on the far western side of our AO near Hurricane Point, the location of our battalion's main headquarters. At this time, the Iraqi battalion was located on the main forward operating base of brigade back at Camp Ramadi. There were no main elements of the Iraqi battalion headquarters outside the wire from the main brigade headquarters piece at that point. They had forward elements of a company, which was co-located with one of the relieving unit Marine companies, but the entire battalion was not located forward. [01:16]

Though not initially assigned to them, we were very fortunate in that the military transition team assigned to our partner Iraqi battalion, also came from 1/6 Battalion. Not unlike other battalions, we had to create a military transition team comprised of our own personnel, not knowing whether they would be working with our own battalion. They had to serve the current needs of MNF-West. We were hopeful that they would be partnered with us because of the shared experiences from Fallujah and their understanding of the application and importance of a combined action battalion approach. We were able to request a change in the military transition team's assignment through MEF Forward, which facilitated that change. Again, their assignment to our partner Iraq battalion was very fortunate for us because of the critical role these individuals played in implementing the combined action concept during our pre-deployment training.

This was very important! From a layman's perspective, if you invest ten or eleven dollars and get three-hundred back, you would certainly pursue that every day of the week. Well, for the ten or eleven quality Marines assigned to a military transition team, I can potentially have, as a result, three-hundred-plus employed Iraqi Security Force as a combat multiplier within our AO. Who would turn down that? Nobody! [03:28]

We've already said that permanent, persistent, and credible presence is fundamental to gaining trust and confidence, as well as improving security and stability, but it can't

simply be improved during the “work day” only, or through a limited commitment. The only way you’re going to improve that presence is a full commitment to being there. You have to live there. Once established, the only way to expand that permanent presence is through two factors: increasing the capability of the Iraq Security Force or technology. It is only through these two factors. I am not going to get anymore capability, and I am not going to say I don’t have enough Marines, because I can’t do anything about that. We have senior officers working on that. Right now I am just going to worry about things I can do something about. The Iraqi Security Force and technology are the only aspects I can potentially influence and develop. [04:28]

Let’s start with the Iraqi Security Force. In order to increase the capability of this force, we invested quality people within the military transition team. Our battalion XO from Fallujah was assigned as the lead for that transition team, and almost each member had made the deployment to Fallujah. Their assignment to the military transition team affected our battalion because they were assigned to that duty full time. We took them out of their primary roles throughout the battalion and put them in a full-time training plan based on my former battalion XO’s experiences and mission requirements from higher. So the team met, trained, PT’d [physical training] together. They coalesced as a team and worked everything having to do with improving that Iraqi Security Force because they are supposed to be trainers and teachers of a battalion staff. No matter the MOS [military occupation specialty], all needed to understand how to wear more than one hat. Just because you’re a Motor T [Transportation] Chief doesn’t mean you don’t need the ability to communicate with an Iraqi Operations Officer. The Marines had to cross train in order to become proficient at different skill sets. [05:55]

In addition to learning the fundamentals of shoot, move, and communicate, and proficiency in all types of pieces of equipment to do their job, these Marines trained extensively on cultural awareness, communication skills, and the like. As a matter of fact, during the training at Mohave Viper, we adjusted our training so that the military transition team could conduct a mobile assault course as a motorized platoon; once again developing that confidence and proficiency in all their potential roles within the transition team. More importantly then, we took those individuals and made them part of the training team for our entire battalion. Now, the battalion becomes a training aid for those Marines as they learn how to become an instructor and a trainer. They took the same classes that they provided, as an extension of TTECG [Tactical Training and Exercise Control Group]. This was a great opportunity for that group of NCOs and officers to learn not

only how to teach a skill. On top of this, we had started to provide HMMWVs [high mobility multipurpose wheeled vehicle or Humvee] to the Iraqi forces at that point, so we started to translate information into Arabic in order to have ready-made classes. Though it seems like a small thing, putting the right personnel in the military transition team and dedicating time to their training was absolutely critical. [08:07]

We were very fortunate that the decision was made for them to be partnered with us so that, now, we have a combined action battalion, where, as far as I'm concerned, I am the transition team leader. That team and the battalion are one entity at that point, which was very effective! When a transition team is perceived as operating alone and unafraid within a battalion's AO, you start to see the team get piecemealed out to the Iraqi companies. Well, who's training the Iraqi battalion? Who's training the battalion headquarters? You're never going to transition greater responsibilities while operating under those conditions. So I thought our military transition team was best suited to train at the Iraqi battalion level. This decision didn't negate any of the responsibilities of my battalion operations officer and intel officer. When we got on the ground, we immediately set up a weekly ops/intel meeting, where we shared information but also provided some training. In addition, we identified common ground for follow on employment based on an assessment of what was going on at the ground level. Sharing information and creating a unified approach to our operations paid big dividends. [09:39]

My old battalion XO, Joe Jones, knew what I was thinking before I thought it, and interacting with our Iraqi counterparts was not by chance because I would talk to Joe beforehand. I would ask him, "What do you need from me, what roles do I need to play here? Do I need to be a hard guy, more firm about something? Do I need to come in and 'chew your ass out' in front of him because you are not supporting him in the way he would like? By doing so, I am reinforcing his and my positions as commanders, his as support, and taking observable corrective action.

These different roles are necessary in order to demonstrate our cohesiveness as a team and our progress forward. It's not meant to be disingenuous, but at times it becomes necessary if we are to identify problems with that battalion's development in a particular employment aspect or identify solutions for solving their own internal problems. I could potentially assist them in these different areas, and this communication enabled me to understand how I could best support them. These were all deliberate but key actions on our part. [11:05]

Going back to the RIP, we were conducting with the existing unit, we completed the transfer of authority with the relieving unit. We moved into pre-established positions, knowing the direction we wanted to move and how we wanted to progress. The Al Anbar Government Center was located in the center of our AO, the Governor of the province lived within our AO, and we provided security for him to and from work. We obviously provided security at the Government Center, which was extremely important. If we wanted to communicate the improvement of security to the Al Anbar province, then it was important that the Government Center not be perceived as being under siege. Perception is reality, and, at this point, based on the insurgent forces' freedom of movement in and around the souk [market] and the inner portions of the city, it was perceived that the Government Center was basically under siege. This perception is a good economy of force factor for the insurgents. By simply having a small number of insurgents, maybe one or two, fire a clip of ammunition at the Government Center and then run away, they simply win the IO battle. Now the governor has to be escorted to work every day and no one is coming into work. If you can't secure your own capital city how can you assure the population that you're going to secure all of the Al Anbar province?

[13:04]

In order to achieve this security, we needed to move the violence away from the Government Center as part of phase one of the plan [see figure 1]. The greatest friction point was a lack of freedom of movement and action for friendly forces within our own AO, so we moved first into the middle of where all of the enemy activity was originating. We put together a plan where we seized a piece of key terrain, a building or structure on 17th street that would serve as a starting point from which we could expand outwards. Later this building became 17th Street Security Station with our Alpha Company in the lead. This movement was a combined effort, a brigade effort in which we had support from all across the brigade in the MEF to support it. As soon as we moved in, 85 percent of all indirect fire quickly fell on top of that position because the enemy didn't want us there. That was their home. They moved about freely in the souk, as well as, what we call "the Race Track", across from the Government Center. They moved about freely while we did not. [14:35]

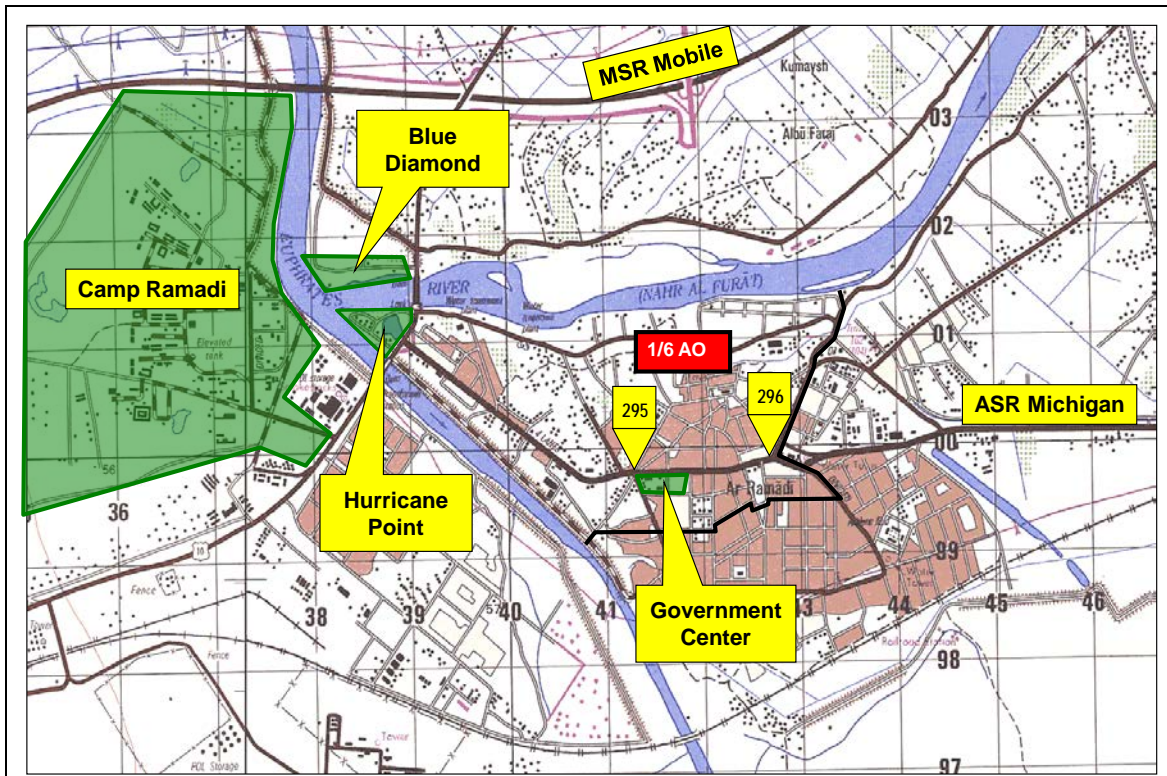

Figure 1. Orientation, courtesy 1/6 Marines

With approximately 125 possible IEDs and hot spots located all throughout the area, our intent was to be able to defend the area against complex attacks within 96 hours; almost like an amphibious landing. Back at Camp Ramadi, we had a series of teams and equipment, communication personnel, tents, drivers, and security personnel, all ‘racked and stacked,’ ready to be called away when the situation allowed. I do not want to represent this operation as a full-on clearing, because we weren’t clearing every piece of dirt around us. We cleared what we had to in order to seize that piece of ground. Then we could work from inside out starting with the 17th Street Security Station.

In order to undertake not only this operation but the continued push across the city and the establishment of a permanent presence, you have to assume risk. You have to assume risk at other fixed positions where only two or three platoons were located, in order to take on the offense. The best defense is a good offense. Sitting in position and simply returning fire was not going to improve security and stability, or the perception that the Government Center was under siege. In order to do that, we had to push that FLOT [forward line of troops] away; we had to change that perception. That is what the four

block plan was fundamentally designed to do. We executed this plan in coordination and conjunction with our partnered Iraqi Security Force element. We had lengthy discussions about moving off of Camp Ramadi into the AO. Those discussions included asking our Iraqi counterparts how they would secure this area in Ramadi if, for example, we were to leave Camp Ramadi immediately. We stressed to them that security and stability could not be achieved from Camp Ramadi. We identified locations throughout the AO for their forces, which would, over time and given the proper conditions, become secure and stable facilities. [17:12]

Through these discussions and coordination, we strengthened our relationship and the trust between us, and were able to permanently move his [the Iraqi battalion commander's] companies into positions alongside our own companies. I'd never ask his forces to do something that the Marines wouldn't do. He had to come to believe that. We would tell him, "You are not going to move an unprotected vehicle out to a position beside the hospital," for example. "Your soldiers will move under the same protection, and with the same prudent scrutiny that the Marines move. We'll move you in our vehicles, and I will ensure you have the sustained logistical support you need." It is important to never say something you're not going to do. Another Marine or US Force would not expect any less, and I certainly treated him as a peer and as a counterpart. I can never go back on that. Over time, as we moved into dangerous situations, we were building his confidence not only in his forces and his transition team, but in my integrity and my word. As a result, he continued to move out with us. [18:29]

The 17th Street Security Station was a catalyst for moving right into the heart of where the greatest threat was coming from, and we immediately established a contingent of Iraqi military there. Soon thereafter, we were looking to include the presence of a police force. Though it was not called the Al Anbar Awakening at this point, the MEF and certainly the brigade commander were engaging in dialogue with Sheikh Sattar about his support for police, and that was great. But I have to tell you, his support came from the rural area. To me, Ramadi is within 200 meters of that Government Center, the city proper; not Jazeera or Tameem, or the outlying areas. Sattar came through tenfold. When he would tell the brigade commander that, through his folks, 200 recruits would be there, he would ensure that 200 recruits were there. His commitment was absolutely a positive thing! But those recruits weren't coming into the city to be policemen. Some of them worked on the outskirts of the city at the West Ramadi Police Station, but they did not venture too far from the police station. Now that's not to be a disparaging comment. I

applaud their courage to become policemen to begin with, but we were still looking for local recruits; somebody from the city. The reason being that we were having daily interaction with the governor who had not been extremely supportive with the police recruiting efforts up until that point. That is anecdotal, but I wasn't there and that was the perception. [20:34]

Once we set up shop at the 17th Street Security Station (see Figure 2), however, we locked down the streets, and people came to realize that we weren't going away. Just prior to kicking that off, I told the governor he would need to stay home for about the next four days, making him part of the plan. He was also a part of the planning process. I talked to him about different places throughout the city in which we needed to cut off the flow of traffic for various neighborhoods in order to restrict movement in and out of the city. A gated community concept if you will. The governor was very much a part of that. Why? He understood the city! He would tell us, "Oh no, you can't stop traffic here because people need to go here." We needed that type of insight from someone who understood the city and the people. It was at this point that he came to me with a list of 120 people from the city proper that he had vetted and screened, and thought capable of leading that police force. Within 24 hours we built a police station for them with 24/7 Marine presence. That was the Al Warar Police station, which was absolutely the turning point for follow on combined actions within that city. [22:17]

The commander that the governor had identified was very brave, and just an amazing guy by the name of Lieutenant Colonel Salam. His life was threatened from the very beginning of our working with one another. He was later killed in a suicide car bomb. Returning to the governor's list, we went back and scrubbed the names against our various databases to see who didn't check out. I sat down with Lieutenant Colonel Salam, our Iraqi Army battalion commander, and basically discussed how all three of us were going to work together. I stressed to them how important it was that we not allow the enemy to divide us because that was what they would try to do. A local security force is an insurgent's worst nightmare because they know who the bad guys are. The security forces personnel may have even, whether actively or passively, participated themselves as insurgents at one point or another. This was not going to be a good news story for the enemy. [23:43]

Prior to this conversation, I sat down with the Iraqi Army commander, discussed that we are the professional soldiers, and he is a Shi'a. I told him that, "On more than one occasion you have said that these people need to start securing their own city. Well, we have

an opportunity, and now you and I are going to have to work with him, we are going to have to support him.” Now, I’m thinking not only in short term, but the long term as well. That is the decoupling plan where the army supports the police when and where required. We had to start developing this unified mindset, and certainly be prepared to head off any problems that may arise between Shi’a and Sunnis, and the fact that we were dealing with policemen who had not yet been officially trained to be policemen.

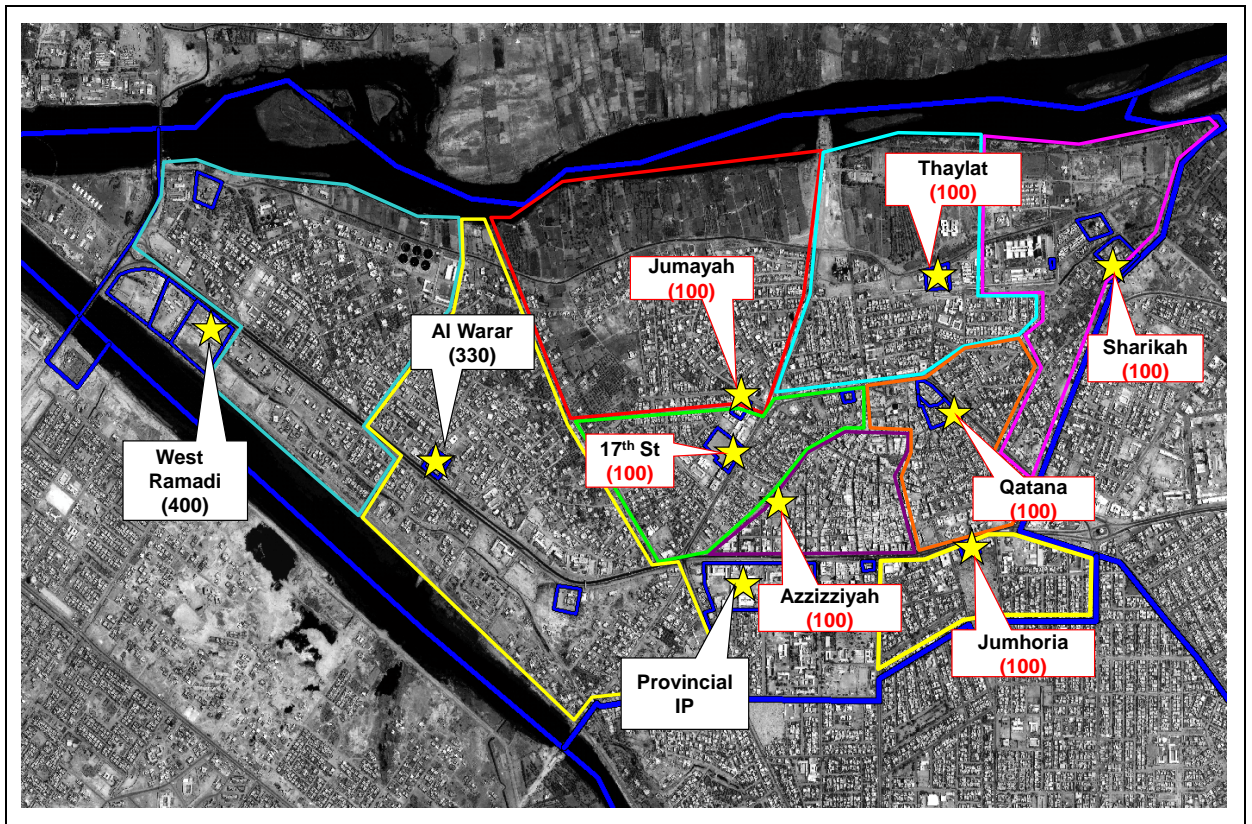

Figure 2. Police Station locations by March 2007, courtesy of 1/6 Marines

These were potential issues that we could see coming, and so we all sat down and discussed them. These are grown men who I had to basically say “Look, there’s no doubt that we’re going to run into problems. I have young 18-year old men that are going to make a mistake, but before we have a standoff and break down all the goodness that we’re building up as a team, let’s put everyone in their corner and all come right back here so we can sit down and work this out as adults. Does everybody agree? Salam, you know one of your policemen is going to be a smartass and stop one of these Iraqi Army

guys when they don't even like each other to begin with? What's going to happen next? Somebody is going to pull out a weapon, point it at someone, and then someone will get arrested. We cannot let incidents like this come between us. Let us not say if it happens. Let us say when it happens because we all know it will."

These guys are professionals, they're grown men, and they've been around. Their response was, "You're right, it's going to happen." Then I said, "I'm [Col Journey] going to go communicate to my subordinate commanders what will happen to them if they don't follow my instructions, and I need you [Salam and the Iraqi Army commander] to do the same, because we all know that's the first thing the enemy is going to do; they're going to try to divide us. It is just a matter of time." That was a key piece of this continuous relationship-building process. [26:08]

As we stood up this police force of 120 men, we had to establish a couple of rules; one being that they had to wear a blue shirt. Now, this is all in the early stages, and we're putting these individuals on a roster to eventually attend a follow-on police academy in Jordan. There are only so many people that can go to the academy at one time, however, so the brigade had to create an interim police training facility over on Camp Ramadi, which was great.

To augment that, we created what we called our "augmentation teams." We started with this 120-man force, but what we were looking to do at that point was take some of those individuals and put them in the 17th Street Security Substation. Now we have a substation, and we want to continue to expand the Iraqi security presence because these guys represent indigenous R&S [reconnaissance and surveillance]. They know the people, and they know the folks in the community. You go up and knock on the door, the guy comes to the door, and immediately the woman starts crying because they recognize that this guy is from their street, and he's in a police uniform. So now, the situation is miraculously becoming better, and we need them to expand their permanent presence outside of just this one police station that we had just built. We need them to continue to move forward. [27:41]

At that time, we only had one police transition team of National Guard troops, which was at the West Ramadi Police Station, and it also has other responsibilities. And we worked with these guys and the brigade. But we had a four block plan that anticipated expanding our permanent presence all the way across our AO. This expansion would result in multiple police sub stations. A part of IO, when building 17th Street Security Sta-

tion, was to use the term *security station* as opposed to *COP* [Combat Outpost] because it gave a greater impression of improvement, that stability and security was getting better. We presented this idea of future police stations to the local populous using that first police as a representation of the direction we were headed.

So as we talk about permanent partnerships, we are taking and forming these augmentation teams out of hide. We hadn't previously trained them up, and so the company commander basically sat down and together we identified a guy who was originally a rifle platoon commander but would now be leading the newly formed police transition team—we called them augmentation teams. Each company created a variety of these teams which represented general support for the battalion. [29:19]

The first and key one was the Al Warar Station. The company XO for the H&S Company, which was a full-on, maneuver company for us, had battlespace. We created another maneuver element out of H&S Company by taking individuals from the rifle companies; we created motorized units within H&S. I've got a school-trained 0302 company commander, XO, first sergeant, and gunny with no other capability. You go back to lessons from Kosovo, you need multiple decentralized headquarters elements to control expanded permanent presence across the battlespace. This type of presence would not be possible with just three rifle companies. H&S Company owned both of the entry control points [ECPs], which achieved consistency in our procedures. Partnered relationships remain the same between the H&S company commander, the Iraqi Army, and the Iraqi Police at those ECPs. What you achieve is ownership, and that first police station again ties right back to that H&S company commander. [30:37]

Knarr: What is the relationship then between the 17th Street Security Station and the Al Warar? Are they the same?

Jurney: No. The Al Warar Police Station was a standalone police station where we placed an augmentation team of about eight Marines who lived permanently inside that particular police station.

Knarr: Where was that located in relationship to that Government Center?

Jurney: It was just west. Once again, you do not want to over-extend, so we didn't put them right in the heart of the most contested area.

Knarr: So you secured from west to east?

Journey: That's right. In between the West Ramadi Police Station, which was on the far west, and the 17th Street Security Station, Al Warar was in the middle; a location identified by the governor. We sat down and we looked, most of their families lived on one particular street, and I sat down with the governor to establish his base of operations. We had Marines living there 24/7. Whether it's the 17th Street Security Station, Al Warar, or any of the future positions, they had all the same force protection measure that would be in place for a Marine Unit. Security became a brigade-level effort, at that point engineering, SAPPER Company in direct support with our engineer platoon and all of the materials, equipment, and personnel needed to safeguard those positions. Because the last thing we wanted was for the enemy to either push us off one of our positions or blow one of the officials or their family up. Such an incident would be an IO victory for the enemy. You just can't let that happen.

You are already assuming a risk by having a minimal footprint because of sheer troops to task, [ratio of troops to tasks], but you almost can't not assume that risk. Some consider it too risky to spread out and move in like we did, but I submit to you, it's too risky not too. If you sit in isolation, and don't have any visibility over your AO except when you drive in and drive out, that's too risky to me. I'd rather be there 24/7 so that I can operate on foot. That's exactly what happened. From 17th Street Security Station, the enemy now had to look in multiple directions, because we started moving more on foot, not to mention that we had established a launching pad for follow on major operations into the rest of the city.

Once we were established, we just continued to move across the city, and again, our operations were then synced up with local Iraqi Police and indigenous R&S. Now the Iraqi police chief is telling me that he was more concerned about me shooting him than he was about the enemy. But the problem in the past would have been that when they identified a fleeting target—a hardcore bad guy who just entered the city—when they get word back to the souk and the coffee bar that he is there, then they need to move. They need to move in 15 minutes or less. The big and slow military machine is not capable enough, nor flexible enough to operate this quickly, but when I have a 1st lieutenant living at the police station; it is just a phone call away. When I would go down there everyday, I would tell the police chief, "You're looking tired. You need to get some sleep. You know this lieutenant works for you. He should be awake, not you!" We would laugh, but he needed to understand that the minute something happened, he just needed to tell the lieutenant. The lieutenant would call the CP [command post], we would put

together an operation, go weapons tight, and then execute. Whether they are in the lead or we are, we wanted him to understand that we were going to do anything he needed; CASEVACs [casualty evacuation], QRF [quick reaction force], ISR [intelligence, reconnaissance and surveillance], or any other operations. That is a combined operation and it's moving out in minutes, not hours. [34:36]

Knarr: You talked about the developing intelligence and your R&S. Did the HETs [HUMINT Exploitation Teams] help you develop those intelligence/source networks?

Jurney: Absolutely! There were multiple avenues of information that we were able to feed off of while we were there.

Knarr: What Iraqi Army battalion did you have?

Jurney: 2nd Battalion of the 1st Brigade, 7th Division.

Knarr: When LTC Salam was killed who took his place?

Jurney: LTC Salam is still renowned as a hero; just mention his name when you go over there.

Salam's second in command, Ahmed, stepped right up, never missed a beat and continued the fight from there. I want to say that was in January timeframe, so the 17th Street Security Station was within its first 30 days of existence.

At this point, we had a local police force and the Iraqi Army and the 17th Street Security Station, and follow-on operations concentrated on expanding that police force and our area. Our operations almost reflected the island-hopping campaign of World War II in the Pacific. We actually used the names from that campaign in titling our own operations that we executed in Ramadi.

Looking at the four block plan, we began to expand our permanent presence from west to east by seizing strategic locations within the city. Once we had seized a key piece of terrain, we would take one more step and seize another, and our operations reflected this pattern. By establishing a permanent presence, we created a visual connecting file in which the enemy was increasingly unable to gather intelligence on our operations and movements. We would seize another strategic location in the city and limit their access to information further, until eventually we pushed them out of the AO. [37:49]

All these operations, and others, were being conducted concurrently. While it may have seemed that kinetic operations were only being conducted, humanitarian and relief operations were being conducted at the same time. The Iraqi Police and Army provided sup-

plies to the Ramadi hospital, further reinforcing their legitimacy as a security force and their ability to provide services to the local people. [38:24]

When we started out, there was about \$10 thousand of aid and civic action projects at work, and we eventually moved that up to \$10 million before we were done. We began with projects as simple as removing a significant number vehicles from the side of the road that had been blown up, including the governor's. Those vehicles were a great place to plant IEDs, which made it a force protection issue. Certainly, the large number of blown up vehicles on the side of the road did not give the impression that the security situation was improving. In order to fix problems such as these, we started contracting locals to basically remove these vehicles, and paid them accordingly. Some people questioned the feasibility of such a project on the grounds of repercussions from the insurgents against the Iraqi contractors. That argument certainly has some merit, but the Iraqi will have to make a life choice: either take a chance removing the destroyed vehicles for a hundred dollars, or chance placing an IED and getting shot. There is danger in both options, but which one did they want to choose? They could see that we were not going anywhere, not to mention that our efforts to strengthen and expand the capabilities of the Iraqi police were gaining momentum. [39:43]

The junk car removal was just one small part of our initial efforts. We purchased tens of thousands of dollars worth of rice, flour, cooking oil, sugar, and we have a number of mobile generators available. When our combined patrols would go out at night to talk to people, the Iraqi Police would be up front delivering the care packages while the Marines stayed in the background. Again, we were reinforcing to the population that security and stability was improving; that a local legitimate police force was present and there to help. All these humanitarian, relief, and expansion operations all happened concurrently. To neutralize the enemy, I didn't necessarily have to kill or capture every one of them. [40:48 end of tape 2]

As we were neutralizing the enemy, and training and employing the Iraqi Security Forces, we conducted civil-military and information operations. Again, we felt pretty strongly that if we could create jobs, provide basic services to the people, and other similar civil action, we could, in fact, neutralize the enemy, or certainly help in neutralizing the enemy. Just like you wouldn't discount the effect of mortars during a conventional battle, why would you negate the combined arms affect of your civil affairs team? We had a very good civil affairs team in direct support of the battalion. They were very capable,

but similar to our combined action battalion approach, they needed to be integrated and a part of the overall battalion effort across the AO. [01:15]

For that reason, we created a non-kinetic effects working group within the battalion. My battalion XO was put in charge of that, and we were fortunate to have two majors from an infantry battalion, the operations officer and the XO, in charge of two of the most important operations an infantry battalion was expected to do. The battalion operations officer was heavily involved in offensive operations, defensive operations, and all that those entail. Additionally, he was dealing with the brigade headquarters and responsible for all the information operations and civil-military operations. All in all, the operations officer had a pretty full plate.

All too often, you will see those two [IO and CMO] things be an afterthought of an organization because the organization just doesn't have the bandwidth to put on it. So our battalion XO led that group. The OpsO [operations officer] and intel officer were absolutely a part of that and in this scenario, the OpsO gets what he wants, namely effective and productive tactical advantage related civil-military operations, but now we've operationalized our battalion XO to lead that effort. Instead of being a glorified adjutant or bean counter for the battalion, the XO was then affecting one of our main lines of effort.

He was also, as our chief of staff, tied into every piece of coordinating that staff and all of its support capabilities. That civil affairs team was no longer ad-hoc, isolated from the command group, and unable to get the logistical support or security elements they needed. They became an integral part of the battalion's effort, with the battalion XO "swinging a big hammer," making sure that these operations received the attention that they needed, and were not an afterthought. [03:24]

With that being said, the battalion XO and the civil affairs officer were involved every day in engaging with key leaders such as Sheikh Sattar and other individuals outside the command as it related specifically to our AO. They helped in establishing local governance when we stood up the local district council. These officers dedicated 100 percent of their attention to these operations.

As our civil affairs team conducted these civic actions, we made sure they were synced up with our offensive and defensive efforts so that they would complement each other. The civil affairs team provided the necessary information piece to our operations. The bottom line was that we communicated to the populous what was going on, which was done by word of mouth.

The narrative was being owned by the enemy, and we were not breaking into that whatsoever. Flyers, things dropped from the sky, were all worthless. I would have liked to have been on TV every day if it had been possible, but that was not an option. We took advantage of every opportunity we had. At the entry control points where thousands of people came through each day, we would take something as simple as a white board and present information and events in Arabic, as soon as they happened in the city. This ensured they knew our version of anything that happened. Our intention was not to mislead them or conduct PsyOps, we were simply communicating to the populous the good things that were going on. We wanted them to know what their local city council was working on, what jobs were being created, or what we're doing to reopen a school in the area. If the enemy attacked an area and people were injured, we wanted to ensure the people knew their own police force had responded to the situation and provided medical assistance. These were the things we wanted to communicate to the populous. [05:41]

This group of officers in our non-kinetic effects group sat down and tried to figure out how best to communicate our message to the populous. There was no newspaper and we were not going to be able to get on Arabic TV. One of the things that came up during these discussions was the broadcasts that came from the mosques. Every day, people received these broadcasts. As a matter of fact, we had been tasked to monitor the broadcasts and ensure they were not disseminating bad information or things relative to friendly forces. The question raised was, "Why can't we have loud speaker broadcasts," and that was exactly what we did. That was the beginning of one of our IO efforts to communicate to the people in the "Voice of Ramadi." [6:29]

In order for something to be credible and legitimate, it needed to come from an Iraqi police station—the idea of "for Iraqis and by Iraqis." We went out and purchased loud speakers. Now, it's important to understand that there were other military mechanisms like PsyOps vehicles, but that was not what we needed. A young man by the name of Adel was instrumental in developing this. He was a cultural advisor and interpreter, an integral part of our working group in recording and releasing these broadcasts. We had a basic format. The transmission would open up with the Iraqi National Anthem, and then we would have brief news pieces, similar to BBC or sports news. For a couple of weeks we would transmit these broadcasts from the police station, and people actually started coming out of their houses when they heard the Iraqi national anthem. Soon after that, we started including public service announcements. They weren't PsyOps products. We would basically communicate the efforts of the local Iraqi Police to identify and get rid

of the insurgents. We called the insurgents “criminals” and “terrorists” because that was what resonated with the local people, not the term *insurgents*. These were all things we found out being partnered with the Iraqi police. [08:15]

These broadcasts continued to grow (see Figure 3). We had the governor give local broadcasts. He would sit down in my office, write a speech, and then record it. Local leaders, Sheikhs, and eventually a mayor participated. We were able to communicate information on the enemy, the police efforts, and any civil-military operations that were being conducted at the time. All these things were being communicated. We had reactive messages from each one of the security stations as we moved across the city into multiple locations. Each one of these locations had a broadcast. Everything was almost interconnected, like counter battery radar. We wanted to be first with our message, and we knew it was working when after a couple of weeks we started to see a significant increase in the enemy’s efforts to refute our message. At one point, there was a black Opel with speakers in the back, driving around town trying to refute the message we were trying to deliver. They were immediately targeted because of who it was and what they were saying. We had other mechanisms for getting feedback. We also knew it was effective when these recordings were duplicated and found in other countries. LTC Salam’s speech would make the hair stand up on the back of your neck; absolutely inspiring and it was being recorded. [09:44]

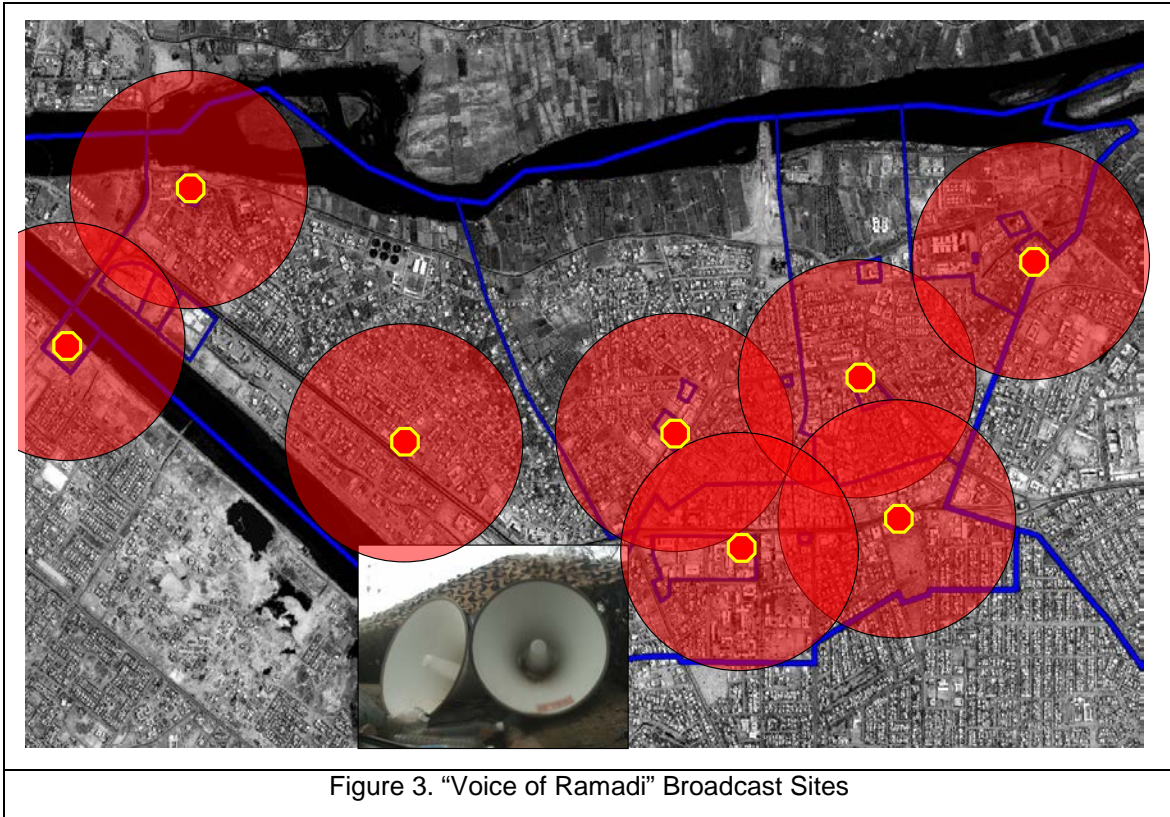

Figure 3. "Voice of Ramadi" Broadcast Sites

In addition to these information victories, we also had reactive messages that each one of the security stations could provide. If a firefight broke out, a message would come through the loud speaker for families to get their children in, and that the criminal and terrorists were at it again. We were immediately able to place blame, not on the Marines or the police, but on the terrorists. Right away we protected and served the people; that is what the police are supposed to do. So in the end, it was credible. It was by the Iraqis and from Iraqis, and that was the way it was perceived.

We followed up our broadcasted messages with other techniques such as creating videos. You hear stories of people trying to counter insurgent messages presented on DVDs that had been disseminated by the insurgents. We decided we could make our own. We found that the police enjoyed seeing pictures and videos of themselves, and so our non-kinetics working group working with the MEF and PAO video-taped the local police during operations; combined it with other actions, and made thousands of copies. The police were happy and proud of what they were doing, and the people were able to witness their local police at work. We did the same thing for the CMO activities in terms of communicating the projects. If an Iraqi lived in one part of the city, he may not have

been able to observe the sewage clean up or electricity projects going on in a different neighborhood. We would show them the video and ask, “Wouldn’t you like some of these projects to come to your neighborhood?” The security situation may not have been such that we could actually provide the electricity grid needed, but I could show them that it was possible if they helped us find the insurgents. [11:57]

Knarr: You wanted to talk transition.

Jurney: From the individual to the unit to the battalion, the one essential key I would add would be transition. Looking at a young Marine who can go from a full-on fire fight to handing out candy, just as objectively, that is transition. That is what that Marine trains for. When I said “shoot, move, and communicate” during pre-deployment training, it is not done out of context. Shoot, move, and communicate is executed within the context in which we expect him to be employed. I have not been around too many people that do not expect to be employed in situations when there are no civilians around. The Marines can understand that. Every training scenario should support that, as should the company and battalion. Transition spans the organization, and I can’t say enough about developing this capability throughout training. People will get “stale” at transition if it is not trained continuously.

The key to transition is making sure that everybody understands why. Why are we protecting and building this school? The answer is that the Iraqis are then going to appreciate our efforts to help improve security and stability. They are then going to tell us where the bad guys are, putting us in a better position to neutralize the insurgency. Someone just needs to tell the Marine that, and they will understand. In their minds they are thinking, “I’m a hardcore Marine, I didn’t come over here to dig a well. Now that you have put it into context and told me why we are doing it, in the grand scheme of things, okay.” We had to communicate this message down to the lance corporals and below. It was not just for battalion commanders and general officers. The big picture needed to be understood at the “pointy end of the spear,” where the rifle squads operate alongside the host nation force. [14:15]

Knarr: A lot of what you have talked about has dealt with communications and socialization. The flow your deployment seemed to be first to socialize the concept with the Iraqis; then implementation; then an assessment, reassessment, and ultimately a refinement of your plan. Can you talk about socialization? Because I think it is a hard concept for people to understand.

Jurney: I think that most of that concept came about because we were extended in Ramadi as a part of the surge. We had already worked our way through most of the 120 days of the four block plan, but once we were identified to remain, we set down once again and needed to have a deliberate plan. We were not going to just wait on our time in Ramadi to end. We sat down and assessed exactly where we were at, and we came up with a plan. This time we had much better “bottom up” communication from company commanders because each one of their individual AOs was a little different and needed to go in a little different direction. Once again, we created another four block plan, whether we were going to be there 30 days or 30 months, and determined what we were going to do for the next 120 days. A part of that was working with a partnered unit, and it was just that, a partnership.

When I would talk with the Iraqi colonel, my counterpart, it was essential he understood that our relationship was not based on a hierarchical structure. If I had a good idea, it was not for me, as an Marine lieutenant colonel, to order the Iraqi colonel to get it done, solely because that Iraqi command knows I control the tanks and he had to do what I said. No. That was not the approach at all. We all sat down and created a communication strategy that involved transition teams, augmentation teams, and company commanders in order to help the Iraqi forces progress.

We were also not convinced that we had the market on good ideas. When you sit down an operations planning team, and direct them to come up with a course of action, everybody is a contributing member. Any number of our operations were modified because one of our Iraqi Police chiefs, whether at the company or battalion level, told us it was a bad idea. We considered those different inputs, and I can't tell you how many plans we made as a result of their input.

These plans were many times as simple as ensuring that people could commute to the hospital for example. We would begin to create sub-plans such as making signs in Arabic directing people to the hospital and task a company commander with the job. The company commander would come back and say, “Here is what we are going to do, and what our signs are going to say.” I would tell him, “Go talk to the Iraqi police chief and show him the plan. He lives here.” The police chief would make corrections, and tell us “first of all, the people are not going to understand these signs as directions to the hospital; second, that is not the way they are going to go; and finally, you never want to put the sign here. As a matter of fact, here is what the sign should say. I will get them made

and put him out near one of our police officer's home. He will make sure the sign does not get torn up or thrown away." A great idea! We were glad he thought of it.

Now, there is a risk involved in working this closely with our Iraqi partners. I am not talking about significant high-end operations because some of those were judiciously not communicated for various reasons, but that was the exception, not the norm. Out of ten operations, nine of them were fully communicated, understood by all, and executed with this understanding. [p18:38]

Knarr: What did I miss? What would you add?

Journey: One follow-up comment on Sheikh Sattar and the Awakening piece. Even though the individuals he was encouraging to be police recruits were predominately from the rural areas, outside the city proper, there was still positive impact within the city that should not be overlooked. Every young man had influences in his life, whether it was his father or uncle or an elder. When those influential figures started saying that to become a policeman was an honorable thing to do, it had a significant impact on people's perspectives. Up to that point, volunteering to be a policeman was not necessarily perceived to be a good, honorable occupation to have. The whole attitude of the population towards the police force started changing quickly when Sheikhs, elders, and others whom everyone respected, communicated that protecting our families, villages, and cities as a policeman, was an honorable thing to do. This attitude shift influenced the 120 names the governor brought me, but did not occur solely by the actions of the governor or Sheikh Sattar, but through a powerful combination that occurred within the city. Within the city proper, it was predominately Albu-Alwani, of which the governor and all the police officers were a part. So was a good portion of the city. Not all, it was very homogenous, but Albu-Alwani was a predominate piece of that. [20:45]

As the police grew and expanded as we moved across the city, they co-located with the Marines and the Iraqi Army in each one of the security stations and the police stations. Eventually, we started decoupling from some of them, leaving them as "stand alone" police stations with just an augmentation team. At that point we had a situation where a company commander would have three police stations within his rifle company's AO. At each police station, he would have one of his platoon commanders or platoon sergeants, so the company commander did not lose people to those augmentation teams, but gained a significant asset. The familiarity and communication link to each one of those positions was permanent, fixed, and available to him. So, once again, he expanded his

permanent presence and influence by one-, two- or three hundred policemen to his former hundred-and-fifty-man rifle company. This was without any Army at all. Now we have a police chief for these sub stations who could identify a local neighborhood leader in order to start a district or local municipal council, which could then determine the needs of the area. The police chief would also identify who, from his area, needed to be on that council and he would, in a sense, hold his own meetings. This idea goes back to Kosovo. The police chief would meet with the neighborhood leader, police chiefs from the sub-stations, and individuals from the Iraqi Army. That is what a rifle company commander is doing. That was the decentralized piece, and it was still nested with the greater battalion, brigade, and MEF Forward initiatives. It all still links together. [22:40]

Within the police stations themselves, there was still friction at times, with Sheikh Sattar. One in particular that I can remember, we had a Security Council meeting and brought all the police chiefs together for lunch. We discussed future operations and the current situation because they were important police chiefs. At one point, someone slid a piece of paper in front of me. Through the interpreter I understood this paper to be a letter from Sheikh Sattar to one of the Chiefs, giving him specific instructions for his police station. This letter put the police chief in a dilemma. What was he supposed to do?

From the very beginning, and this is important, we stressed the idea that there is only one government. There is only one elected government. People can like it or not like it, but that is why we vote. I had communicated this message before, along with the idea that we always respect our elders, always. I would never do anything to disrespect Sheikh Sattar, but in this instance, having stressed the need to respect our elders, but also understand that, as professionals sworn to protect and serve the community, there is only one government, I took this piece of paper and ripped it up. They clapped. They were off the hook at that point.

Here was a situation where they didn't want to push back out of disrespect or the potential implications from doing so. They needed a little "top cover." We later communicated with Sheikh Sattar about the letter, and, in this particular case, he denied having sent that letter. There was a "face saving" factor, but he understood that we were working together, but there were boundaries. We needed to reinforce that idea. If not, then you start to see the presence of rogue militias, which is a concern. [25:04]

6 July 2010

Subject: Interview with Major Jason Arthaud, former Commander, B Company, 1st Battalion, 6th Marines

Major Jason Arthaud was the Commander, B Company, 1st Battalion, 6th Marines (1/6 Marines) from September 2006 to April 2007. 1/6 Marines operated in Ramadi during that period and was responsible for the area east of Hurricane Point to the Government Center, east along Alternate Supply Route (ASR) Michigan to the Saddam Mosque and north to the Euphrates. Major Arthaud's company was responsible for securing the Government Center.

Major Arthaud was interviewed at Quantico, Virginia, on 24 March 2010 by Dr. William (Bill) Knarr.

Dr. Bill Knarr: Please state your name and provide some of your background.

Major Jason Arthaud: My name is Major Jason Arthaud and I was with 1st Battalion, 6th Marines [1/6]. We arrived in Ramadi in August, 2006. We were due to return in March. We were extended as one of three units extended in place for the Surge, so we ultimately returned home in May, 2007.

Knarr: And what was your position?

Arthaud: I was the Bravo Company Commander.

Knarr: What were the conditions when you got to Ramadi and were they what you expected?

Arthaud: The conditions were bad. I mean, during work up it had been identified where we were going, so our work up was tailored to the extent it could be for that. Other than that it was a normal PTP cycle, crawl, walk, run phase culminating in the Mojave Viper exercise, Twenty Nine Palms. It was during Twenty Nine Palms we did a video teleconference with the 3rd Battalion 8th Marines [3/8] in Ramadi, so we were able to exchange information with them and tailor our block five period, which is basically your last month to train on some of the AO specific practices that they were using. But it was painted as bad and at the time it was fairly common knowledge, after Fallujah that the remaining bad guys were in Ramadi and it kind of lived up to that expectation when we arrived.

Knarr: Did you expect to go into the Government Center before you got there; was that kind of the plan?

Arthaud: That was. It was during Twenty Nine Palms/Mojave Viper when Colonel Jurney had a chance to assess each Company, and based off that he made the decision and then advised us one at a time how we were going to lay down up against 3/8.

Knarr: Did you then move right into the Government Center when you got there, or did it take some time?

Arthaud: We did, and again that's when we matched up with 3/8, we were also able to look at how they were laid down and why. But, first we had to go to the COIN Academy, that was a new requirement, so all the Company Commanders, and Colonel Jurney went to the Academy. It was a good time for us because we were away from the Battalion and we were able to study the AO and discuss what his intent was while we were there.

Knarr: Can you now walk through the sequence of events of your eight months there?

Arthaud: Closer to nine and because we went ADVON, all the Company Commanders arrived in August, so we were there about a month prior to the Battalion. So, we did COIN Academy the end of June and July, and we arrived in Ramadi in August. That allowed us to just observe how 3/8 had been doing things. And then that helped us prep to receive our Companies when the main body arrived. So it was about mid-August that I was there and then 21 September was the actual Transfer of Authority date, and the last guys from 3/8 left.

Knarr: Please walk through some of the major events, the sequence of events during your eight months there.

Arthaud: Ok. When we got there looking at how the previous Battalions had operated and try to learn from their experiences. Most of their casualties were from IEDs, from driving around, so the way to resolve that was to get out in the city that way we're not driving to work. You live where you work. They also had fairly heavy fix site security responsibilities, both at Blue Diamond and in the city. So Colonel Jurney's first action was to get us out of guarding Blue Diamond by moving us into the city. It was very easy for me, because I was due to replace Kilo, 3/8 and they were already in the city securing the Government Center. When we hit town we just went straight to the Government Center.

We had to make a lot of changes because they only had a Platoon there and we had to harden it and expand it to house an entire Company. But, his objectives were to secure, lock down Central Ramadi; secure 295 which was at the time the worst checkpoint, and

then by holding that area that would then enable them to push Alpha Company and then ultimately Charlie Company up into the North West and ultimately northeast areas of the city. Kind of the [ink blot] philosophy the Army talks about, some called it Lilly Pad, but essentially get out and then leap frog into and through the city. And once we were out there we were a persistent presence in all parts of the city. We would patrol everywhere primarily on foot to avoid that IED threat. And, slowly, as security improved, the people started coming out, the IPs would be recruited and then they would gradually take over their own neighborhoods and then ultimately larger sections of the city. That allowed us to get out of our fix site responsibility because now they are manning checkpoints and that freed us up to do more patrols. And that ultimately is what gained us the momentum.

Knarr: Did you have any IP stations that you had to worry about?

Arthaud: Eventually zero. At the time in Central Ramadi, there was no one there except insurgents, and a few residents that were kind of hunkered down in mainly the southern part of my sector south of Michigan. But there were IPs, there were Provincial IPs, sort of like Capital Police. They were there just to guard the Provincial Capital Building and compound. They were all up at Blue Diamond. They would not go into the city. They had already been hired, recruited and equipped so no one was too keen on getting rid of them, but the situation both in reality and in their own perception was that it was not safe enough for them to go down into Ramadi. So that was a challenge.

Knarr: Were you responsible for moving the Governor from his house out to the Government Center?

Arthaud: I was not. A lot of the typical missions like that, and repeated security tasks like that, Colonel Jurney would either try to give those to H&S Company or Weapons Company or he would take them himself. So no, I did not have the responsibility.

Knarr: I read 'When Stars and Stripes are in Full Battle', just all the demolition work that was done around the Government Center. When did that start and why was it done and how did this evolve?

Arthaud: Back I'd say, 2/4 [Marines], 3/7, 3/8 timeframe. Essentially the city had been abandoned, especially in the center, and it wasn't really a residential area. North of the Government Center, at least the first couple rows of buildings, were doctors' complexes, different offices, market buildings or government buildings, they were abandoned and being strictly used by insurgents as firing positions. So they would infiltrate from the

north, come into the back side of the buildings, get up to eye level with the Government Center and then you would just have these, almost daily, small arms fire exchanges with the Government Center. Didn't cause a lot of damage to the Marines or the units there, but it created noise, created an environment that 'Ramadi's bad' because anyone within five mile, ten mile radius could hear it. Some of these fire fights would go on for two or three hours with very little damage to either side. But that was kind of their game, it just keep up the perception that things were bad, or on a great day they would create a casualty, someone would hit an IED, then here comes a REACT or an ambulance, and it just turns into this big protracted fire fight that plays out in front of the residents. That was their favorite thing to have happen and you'd catch them sitting up video cameras to try to get it on film and make propaganda videos.

Over time those buildings were worn down to the point where they're probably not going to be recovered and they're just providing ambush positions, so to gain standoff and expedite the inevitable, was to go ahead and destroy those buildings to clear out that area and primarily gain standoff for the Government Center. So that's what started it. That was done from some Engineer Units, Army Engineer Units actually did most of that and that was still going on when I was there and, throughout our entire deployment, because they had to bring the buildings down and then it was another nut roll to 'how do you crunch up the rubble to the point where it can be manually loaded and hauled away?' and that was still ongoing when we left in May.

Knarr: One of the challenges was getting the Iraqis to join the Iraqi Police and to have them move into these areas; how did you do that?

Arthaud: It was similar with the Provincial Police. There were identified police stations, police chiefs and different personnel for different sectors and it was just a matter of getting the recruits. It's not that they were cowards, but they weren't to the point where they could survive going out into the city and saying, "Hey I'm the Chief of Police." They would have been murdered. So it was really them partnering with Alpha Company and our H&S Company and getting comfortable and confident in the Marines that, "Yeah you are going to sit here with us and help us if need be and take the lead if we're not comfortable" and that's what happened for the first couple months. But, over time, they were brave and as they saw the situation was permissive and we would help arm them, we would get them body armor when we could so they felt like they weren't being thrown to the wolves, and then over time they took it over. It was like, "We've got it!"

Especially in their local communities where they knew everyone, and then it just kind of ballooned from there and went from west to east into the city.

Knarr: Did your unit work with the Iraqi Army?

Arthaud: No. The Iraqi Army had left before we got there. They had been there with 3/8, but I think the Iraqi Army unit was relocated.

Knarr: Ok, so the Army unit left and then they had to generate the Iraqi Police?

Arthaud: Correct.

Knarr: So you had the Provincial Police. Did they; did the Provincial Police then move out once the Iraqis, local Iraqis joined their own forces?

Arthaud: It was sort of unrelated. Like, one of the first operations we did I was just told to shut down [ECP] 295 because that was the worst, you could not drive through it. I know General Allen was shot at numerous times coming down there. So, once we shut down that intersection that allowed us to secure Michigan and we almost had a connecting file between the Government Center, 295 checkpoint and then Alpha Company so we kind of had Michigan with the continuous over watch all the way from Hurricane Point. That drastically reduced the IEDs and IRL, Improvised Rocket Launcher, attacks on convoys coming through. And once that was established we went several weeks, and then months with no incidents.

Then the Provincial Police were willing to come out to the Government Center. Fairly safe for them, I mean they had a whole Marine Rifle Company there, well defended, hardened position. And they didn't go outside the wire, they didn't patrol, they were just the interior guard force for the Governor. So once they got down there, got their feet wet, and it's like, "This isn't that bad" and the Governor was proud that they came down there. So once that got moving we had no problems having Provincial Police down there. And it was kind of concurrent to that where the local IPs were doing the same thing, they gradually stood up, they saw that 295 had been shut down, so that kind of started the ball rolling.

Knarr: Were some of your patrols done with the Iraqi Police then?

Arthaud: Yes. Initially when we worked with H&S Company, if we were going to do a mission where we needed assistance or we just wanted to involve the Iraqis we would tell them, "Hey we need 15 bodies" or "a squad," but we would sort that out to have a quantity of them and then we would go to their police station, pick them up, or someone

from the Battalion would drop them off at the Government Center; we would use them for a mission and then they would return to their police district or station.

Knarr: What did you see as some of the successes

Arthaud: The first thing was 295 and it was just gradually extending our ability to get into the city, and then securing our route back out. And then once that happened we had a secure line of communication, local nationals didn't move up and down the MSRs because it was primarily the government only. But we were able to shuttle back and forth, people were able to witness that we weren't being attacked. They didn't really know why, but it just created a perception that security was getting better just due to the drop in rocket attacks and small arms fire attacks. And then once 295 was shut down we moved, this is November, moved right up into and established the 17th Street Security Station with Alpha Company; they had a highly residential district so no shortage of people there. They were able to start interacting with the residents immediately as far as community relations efforts, generators, power, food, starting getting schools opened. And that was immediately well received and the results were very positive.

That was only one street away from me, but that was a more permissive environment. They operated quite a bit in daylight. So a lot of the COIN theory, they made it reality there. And that was concurrent with their efforts to build up their police force in that area. And they called it 'The Joint Security Station' because they were, from the get go, the police were in their Company Headquarters and they ran a number of joint patrols and established satellite police checkpoints and different police stations in their sector. So they were much busier, and in many ways I would say they had a more complicated mission, just because they had more of the Iraqi National interaction.

Knarr: Plus it sounds like they then worked much more with the people?

Arthaud: Right, and then they kind of became a good PR place. One, it's safer to get to them than it was down at Government Center, and then you could bring people in and say, "Well here's Shia and Sunni sitting here working together, planning patrols, conducting operations and being very successful at it".

Knarr: I've heard talk of the Voice of Ramadi; can you talk a little bit about that?

Arthaud: Yes, we had a detachment from the Marine Corp Warfighting Lab, Major Tiley Nunick had a program that was kind of a micro UAV system that would be used at the Company level. They deployed with us, they partnered with us during workup, they

were out at Mojave Viper and they got permission to deploy to Ramadi with us. Colonel Journey always takes advantage of anyone he can get his hands on so he soon gave him a number of collateral duties. And one of them was assisting with the Unit Information Operations and, “How do we take advantage of the systems we had?”

The scheme that Major Nunick and Colonel Journey came up with was, to counter the insurgent’s ability to put out their IO message and spread rumors very quickly, that was our ability to counter it using a loud speaker system. But then they would also generate handouts that they could disseminate through checkpoints and over time it became like the local radio station, the Voice of Ramadi. They would bring in Police Chiefs or local officials to say whatever they wanted. We would script them out, like, “Hey because this happened you should probably discuss this and let them know what really did happen.” They would do things like that, they would slip in soccer scores, and so it became very popular. The town would kind of get quiet and they’d all listen.

With phones down that became a pretty good way for them to receive information and for us to counter the insurgents IO plan.

Knarr: That was pretty innovative. What other successes?

Arthaud: Another example. As a Police Chief would get on the loud speaker and as they got more confident and brave, they would call out insurgents by name and all the people in Ramadi were able to hear, “Hey there’s this Police Chief saying these guys are cowards and they murdered such and such” where just a few months ago if there was even a rumor that you were dime’ing out the insurgents they’d come find you and kill you or your whole family. But yeah, again as the Iraqis stepped forward it bred confidence in general, and I’d say a hatred for the insurgents. Some went away, some found other things to do, and some were just run out of town, some also, I’m sure were killed.

Knarr: What other examples?

Arthaud: It was a very block and tackle. Get this part of the city, and that’ll allow us to jump here and once that area’s good then we can jump to this area. And that basically played out over about a six months and then we reaped the benefits from it for our last three or four months. It was kind of tenuous because you didn’t really know if things had gotten better or if it was just a quiet spell. But, right around November/December ’06, January ’07 is when I would say it turned. There were some lulls, I mean it wasn’t uncommon to have a week or two go by with nothing happening, But December 15th was our last major attack that I recall.

Knarr: Can you talk about that?

Arthaud: Yeah, that was at the eastern side of my sector. A seven ton truck busted through Two-Niner-Six and then drove into OP Hurrayah and detonated. The attack was initiated by multiple, I think six RPGs shots against the OP giving the VBIED cover to drive into the OP. It detonated on the street, didn't kill anyone other than the driver, but it started a fire, and again that was used to initiate an attack that lasted about an hour and a half. The building was on fire. We ultimately called down a Tank Platoon, which kind of silenced the area for a while. That allowed the Marines there to put the fire out and then the tanks left and it started back up, and drug out for probably about two hours till we ended up with some GMLRS [Guided Multiple Launcher Rocket System] strikes. But, there was probably 30, 50, maybe more insurgents involved in that with multiple support by fire positions. The Government Center was attacked at the same time, but we had a Company Minus there, so it wasn't as tenuous for us. That was later assessed as probably their last, "Hey we're losing the initiative here. Let's get together and plan one big thing and see if we can generate some casualties," and it failed miserably for them.

Knarr: That's great! What about if there was something you could have done differently, what would it have been?

Arthaud: Boy I don't know. And I don't mean that conceitedly at all.

It's just, we were very busy the whole time, exhausted when it was over, you know again ten months, but it all kind of went according to plan. We didn't know the plan would work out that well, but again it was fairly simple. It's like, "We want to be here, and we can't get there" and then just incrementally moved those obstacles that allowed us to do what we wanted. And then it meshed up with our assumption that the people didn't want to be at war for the rest of their lives either, so as soon as they had the opportunity to contribute they stepped up. But as far as within our Company, it kind of went according to plan.

Knarr: Good!

Arthaud: You know, as it evolved, we had an initial plan, kind of phase one and then we built off our success and we were fortunate enough to see progress partly due to our extended deployment, so that was rewarding in many respects that Marines were able to see that the hard work and effort, of not only us but all the previous battalions, finally paid dividends for everyone.

Knarr: Yeah, if you had stayed longer what do you think you would have done? Where would you have put your efforts had you stayed longer?

Arthaud: Again my sector had were fewer people so we were kind of the last to really get into the counter insurgent fight as far as the hearts and minds and partnering with local leaders and the police, but that did happen. The last two months we ended up with our own police station in what was OP Hurrayah.

Knarr: That's the place you were...

Arthaud: Right, that became the Al Jabouri Police Station. Initially they took over the second deck and then ultimately during 3/7's time took over the whole police station.

Knarr: Al Jabouri was a tribe in that area?

Arthaud: It was a district south of Two-Niner-Six. It very well probably is a tribe also.

But that was purely grass roots, that was interesting, a gentleman walked up to me one day wanting to be a policemen and it went from there. But from the ground up its like, "Can you go find ten guys to help you?" and a week later I got 22 guys. And they had worked it out with the other police districts in the city, so they weren't surprised, they had pre-vetted this guy, but it was literally, "Hey can we get blue shirts?" "Yes you can" "How about orange vests?" and over time, "Can we get an AK, and pistol," and just literally from the ground up. But again because it was in their neighborhood, and we were there to support them, they stepped up. Toward the end they had checkpoints all over the city, and in their district, and then they had a functioning police station that was fully under the blanket of all the other stations and they went to the weekly meetings and had quotas for this and that and the other... But from that, once you get your own local nationals, then it really expedites the community relations as far as. So I would say, not that we would do anything different, but we would have been able to pursue that further.

Knarr: I'm trying to draw themes across all these areas. The one theme that seems to pop out is the development of police, the local police. Another that I haven't pursued quite as much is the amount of forces needed for persistent presence; those are things that have been said before. As you've heard the different lessons from different areas, what would you say was unique about Ramadi?

Arthaud: This is backing up a little bit, but I imagine you know about 2/4 and other units that had the whole area, they weren't the main effort at the time. Fallujah took over and that really squeezed the balloon, and as we were coming in it was like, "Well we need to

cordons this place off and do Al Fajr III,” and that’s I think what was kind of interesting, because no one knew how it was going to work and we were basically trying to clear a city without disturbing people. Because it was highly kinetic operations in and amongst people, so there was a significant amount of force applied, it was just in a very precise manner against exactly who needed it and when. It was doing everything possible to avoid injuring anyone else. But that was kind of the biggest dynamic we were playing with, “What is the higher ups going to do?” No one wanted to do a Fallujah again, just because of the cost and the destruction to the city, so that was really the science project is, “Do the same thing as far as clearing it, but with minimal harm.”

Knarr: What about biometrics? You talked about population control, census operations, one of the tools to do that is biometrics, BAT, HIDE, etc; did you use those at all?

Arthaud: We had on those previous deployments. I think they work when they’re functioning. We had them in Fallujah, but as far as my sector no, because we had the minimal interaction with people and then the interaction was usually with the government, or his personally vouched for personnel. And then frankly, everyone accepted, including the Governor, if you came in the Government Center, you were searched.

And they were pretty professional about it. And as far as the census operations, as we went out in the city, we didn’t have those tools, but we would collect what we could through translators, record the names, and different documents, but no we did not use a BAT-like system.

Knarr: Where’s Sunset at? [See Figure 1]

Arthaud: It’s this route here. We actually had an OP Sunset right here. I’ll circle that. I think that [IED that killed Patriquin] detonated here.

There was an Army unit. I can’t recall its name at an outpost down here. They had been down there visiting them and were on their way back. And for whatever reason it’s very dusty; so as soon as a vehicle goes through there’s just clouds of dirt, you can’t see. And the first vehicle went around it and the second vehicle straddled it.

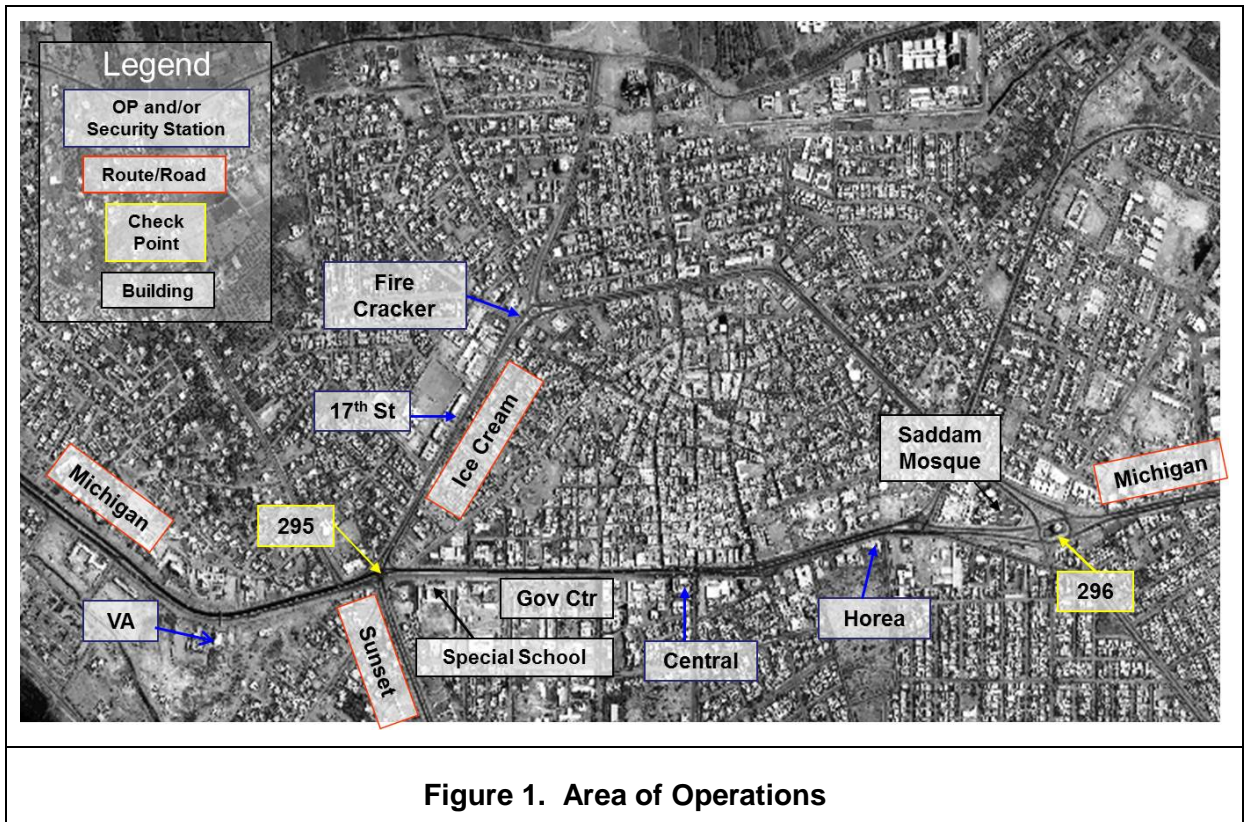

Figure 1. Area of Operations

[Discussion on building and occupying OP 295] There was a building there and overnight we built two posts and as the sun was coming up locked the door, “Hey you guys barricade yourself in here” and they were hit the first day, but after a few engagements they [the insurgents] moved elsewhere. The big question was, “What’s going to happen when the sun comes up?” That was the biggest unknown for me, and just seeing the faces we like shut the door behind them, it’s like, ‘there’s only like eight of you in here’ but they were literally up in a stairwell with grenades and they were prepared to barricade themselves in there and defend until a REACT Force came if necessary and luckily it wasn’t necessary?

Knarr: That’s incredible! Who did that?

Arthaud: That was our Company. We built that ECP overnight; the Engineer Platoon helped. They had an extending forklift. They had prefabricated the Ballistic Post at Camp Ramadi, and it would just barely be able to lift it high enough to put them right on the roof.

Knarr: So that was the Army Engineer Unit?

Arthaud: That was ours.

Knarr: That was yours.

Arthaud: I'm sure the Army unit helped, because they had the heavy equipment, the welding, but they had quite a little cottage industry fabricating deer blinds, or duck blinds out of armor and they had a, where they'd take HWMMV ballistic glass and you could order them and they'd have them done and put them wherever you needed them.

Knarr: You say it was your Company, did a Platoon leader run that?

Arthaud: It was a Company operation to put it in. I don't recall what Squad was left there day one.

Knarr: What did I miss that I should have asked?

Arthaud: Well we kind of skipped over it, but on day one we took a VBIED right there at Sunset right at this intersection and that initiated about a two hour attack. So that sun came up, the last 3/8 guy left, and we had a two hour attack with a VBIED and mortars and 120's. And I don't recall, but I think every position in the Battalion was hit at the same time throughout the city, Alpha Company and Charlie Company also. We had been warned of that, "Hey they know the new guys are coming and the old guys are leaving and the towns all quiet, birds are chirping" and then the old guys leave and then boom, they hit you. But luckily for us it didn't work out well for them, but that really was a reality check for anyone who had any doubts about what we were getting into.

[Looking at photos]

Arthaud: But we ultimately put those 11 foot barriers in the cross streets to block RPG shots coming down, so then that forced them to crawl up in the buildings. Well once they were doing that, in this building we delaminated it, which was a term to leave structural barriers but blow out the walls, so that's what happened here so no one could move upstairs without us being able to shoot them. And then some of these buildings where we just couldn't get to them...

Knarr: delaminate!

Arthaud: Yeah I just made that up at the time.

Well it was Colonel Journey's like, "Hey the Colonel Charlton doesn't want you to drop anymore buildings" I was like, "Well can we knock the walls out and leave the building?" so it was kind of like, "yes you can do that," so that's what that was.

These buildings were persistent, they were like the last ones and we just dropped them. What we would do is we would fill them up full of tangle foot concertina, just snarl it full of wire and bars inside it and spend like hours, a whole night doing this, and concurrently my Assault section would be placing charges usually between 600 and 800 pounds and about the time, an hour before daylight then they would hit it. But the purpose was to blow up the front support and allow the roof to fold

down, and then it would just be a tangled mess of rubble and wire, so that no one could work their way through the building to get to a firing position. That drove them to come to one of these other buildings that was closer that we could see or they were left trying to fire down the street where they couldn't, because there were 11 foot barriers there.

This was all wired; once it got that difficult for them they just moved elsewhere and we would see indications of that. We would do some operation and then there'd be an Army unit getting hit with the same TPs that had been used on us. It's unfortunate, but that was kind of the idea, if everyone does the same thing then they leave the city. But that science project kind of culminated all through this area, and then the death nail was shutting that down completely was we finally just occupied this building. We wired in this whole sector and made it part of the Government Center Compound. Because we were routinely using this building, it's like, 'They're going to rig this to blow on us one of these days' so one night we just went down and occupied it, similar to how we did the school and then we just wired it in and then continually manned it the duration of the

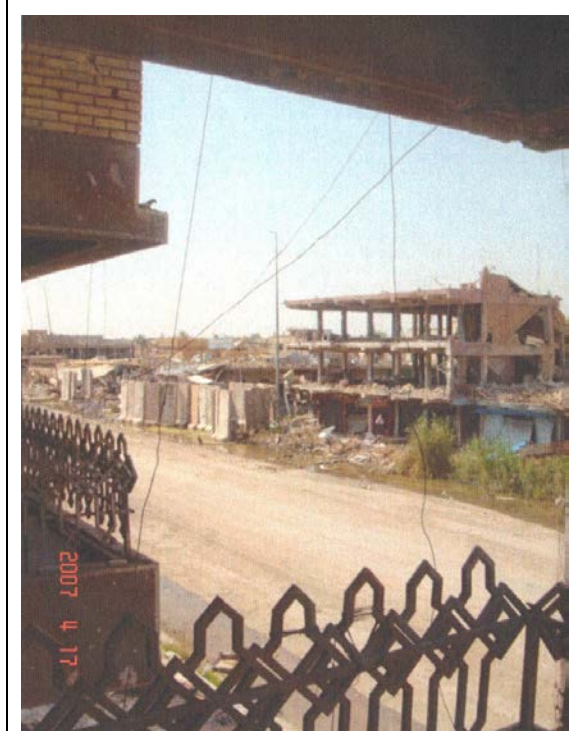

Figure 2. Delaminated Building, Photo courtesy of Major Arthaud

deployment. Ultimately it became a police station, or a police checkpoint. They manned it.

Knarr: You say this was the school? [See Figure 1]

Arthaud: Yes, Special School they called it. And then, so yeah, OP Central was this building. These buildings in between happened to be vacant anyway, so, yes, One, we just wired this off and then Brigade gave us T-Wall barriers, so they eventually barrier this whole area off.

Knarr: Clear down to the Government Center.

Arthaud: We didn't have to worry about it anymore after that.

Arthaud: But the Sniper Platoon was using this, they got surrounded, turned into this protracted fire fight just across the street and we ultimately did a [GMLR] shot in a building right across from them. And we have that one tape.

Knarr: I would like to see; that.

Arthaud: It's good because it shows precision with the ammunitions we had available, because Marines were literally right there on the south side of the road and we dropped a 250 pound bomb that was fired from Fallujah; that's where the Battery was that fired the gimmlers.

Knarr: And that was right across from the OP Central?

Arthaud: Correct.

Arthaud: It was kind of harassing fires. Because, they're not going to seize the Alamo, or seize the Government Center, they would just shoot at it, try to get us in this fire fight.

Knarr: Show people that they could harass you.

Arthaud: This is an IED, this is where your hair on the [back of your neck], because we're all sitting here like ten of us and you start seeing these IEDs coming out, the insurgents right there, but they can't hit him so he's using these barriers and he's pushing this out with a conduit. You can see that he's go it taped together. That pipe. They would just...push it out. They're in the bank just stripping conduit off the wall and taping it together.

Knarr: And they're pushing it out.

Arthaud: Right. And the IEDs not going to hurt these Marines, but what's about to happen is they're going to attack them, do something to create a casualty, and then...

Knarr: Someone's going to respond.

Arthaud: blow up the QRF.

So what happened here, it's kind of like, "Hunker down, kill everyone you can, we're not coming to get you unless you really need it," and that one played out; nothing happened, the insurgents, I think they just had an exchange here, they never came across the street and tried to get in, but they just stayed in their position and then that night, route clearance our Engineer, we basically clear a route to them as if they were in a mine field with K-9 units and everything else, pull them out and then the Pathfinder Route Clearance team would just destroy it. But things like that would happen and it would get very bad if, like if you did call a QRF or tried to extract from a position like this in daylight, I'll guarantee you there's insurgents. They'd have ambush positions set up in all these buildings over-watching this.

Knarr: That's amazing!

Arthaud: Usually when we would do an ambush we would do it as a zone, because you're in buildings and there's only one that can cover what you're looking at. But we'd have maybe a whole Platoon in three different positions so they could have a secure route out, or if they did get attacked they would become the kill zone for another Platoon's position. And there were situations like that where it's like, "Hey you guys get down, because they're coming around your building" and then another ambush position would essentially be firing at the Marines.

Here's another picture of the building that we dropped. Fishermen TTP, that's what that was called, because you had a pole and you'd push them out. And that's fairly famous, we'd heard of that before we got there. This is that first big evolution to shut down 295, and that's where we occupied this building, put the two posts on the roof.

This is 21 September, there's a VBIED that blew up, it hit here, so we have it kind out in chronological sequence of what happened by time [Attached].

And OP Hurrayah was hit at the same time also. This is the 15 December. This is from that, the micro UAV, the Wasp, the VBIED that detonated, it blew up...

This is the Gov Center that involves that first day where we've had that, the VBIED came through 295 and hit this post and then the Gov Center was attacked. They tried to

hot them with small arms fire from the north, from the east, they tried to maneuver and do volley fire rocket shots and encroach on this south ECP. That failed. And this it kind of culminated with some dismounted assaults on this OP. These guys, there's only like a, there's my Machine Gun Section down there as a Provisional Rifle Platoon. But, it's kind of like, "Wow!"

Knarr: Now what day was this?

Arthaud: 21 September, TOA day that was our day, official day one. It was like zero hundred, 21 September we, Colonel Jurney and Colonel Neery shook hands. He left and then Captain Delgado was the last guy, so we dropped him off. They heard it later, because they were at Camp Ramadi waiting on flights and they heard the VBIED blow up. It was about a 700 pound explosive, and my only casualty is a Corporal Taylor was firing his 50 cal into the truck as he drove up. Then he got flash burned on his hands, he was holding all his fingers and then he's just you know, engulfed.

Knarr: What took these pictures?

Arthaud: A Wasp UAV. They would launch it from Hurricane Point. They would have someone pilot it down to us to 295 and that's where they'd usually loiter it, and then I'd have that Corporal from my Clerks, he could fly it, so he'd pick it up and control it. That was really a God send because a lot of the patrols were responding to questions like, "What streets are flooded in your sector?" Maybe we could send the UAV instead of sending Marines to answer those questions.

6 July 2010

Subject: Interview with Major Daniel Zappa, Executive Officer, 1st Battalion, 6th Marines

Major Daniel Zappa was the Executive Officer for 1st Battalion, 6th Marines (1/6 Marines) from September 2006 to April 2007. 1/6 Marines was operated in Ramadi during that period and was responsible for the area east of Hurricane Point to the Government Center, east along Alternate Supply Route (ASR) Michigan to the Saddam Mosque and north to the Euphrates.

As the XO, Major Zappa was responsible for the non-kinetics effects that had a tremendous impact on the transitioning of the central part of the city of Ramadi from a terrorist sanctuary back to the residents.

Major Zappa was interviewed at Marine Corps University on 22 March 2010 by Dr. William (Bill) Knarr and Colonel Dale Alford, USMC.

Dr. Bill Knarr: Major Zappa, please provide your background information.

Major Daniel Zappa: I'm an Infantry Officer. Right now I work at MCCDC [Marine Corps Combat Development Command] in the Operations Analysis Division. I went to Monterey after my time with 1st Battalion, 6th Marines [1/6 Marines]. I got my Masters Degree in Operations Research and now I'm working in the current operations cell doing analysis for the most part on Afghanistan and the MEB [Marine Expeditionary Brigade]. We've got an analyst on the staff there in G3 Assessments. I'm going out in two weeks to take his spot more or less as the MEF [Marine Expeditionary Force] changes command. Then it will be two of us on the staff there. Prior to Monterey, I was with 1/6 Marines; I was there for three years. I was deployed as the Alpha Company Commander. I was Weapons Company CO for six months mostly doing the work up for the second deployment to Ramadi. I became the Battalion XO about two and a half months before deployment and deployed as the XO.

Knarr: Please talk about events. Talk about when you got there. What were the conditions? Were they what you expected? And then talk about the sequence of events that occurred.

Zappa: When we first got to Ramadi we had a pretty good idea of what we were going to see based on the connectivity we had with the unit we replaced, 3rd Battalion, 8th Marines [3/8]. We started talking to them many months before we deployed, probably six months, seven months out. We had SIPRNet [Secure Internet Protocol Router] connectivity so we could exchange discreet information. We didn't have any VTC

[Video Teleconference] with them until Mohave Viper, which was still limited. But when we got there we had already done a PDSS [Pre-Deployment Site Survey] with the key leadership, the CO [Commanding Officer], myself, the OPSO [Operations Officer], the S2, the 4 Alpha, all the Company Commanders went forward looking at how 3/8 was doing business. We got to go out with them and see some of the AO [Area of Operations]. Big difference between that and our previous deployment was, it was all urban and so the lines of communication were not very secure.

So, the CO had a good chance to formulate what his lines of operation were going to be, and what he wanted to do. And so when we got there I think we were really itching to get forward and put our plan in effect. For me, we weren't sure how the non-kinetic thing was going to play out. The CO knew that we had to get the Iraqi Police and Iraqi Army into the city for us to be successful, and that we had to secure our lines of communication. And so that was going to drive where our positions were going to be and it was going to entail an effort from the Brigade as well to support his vision for where he wanted to go. I remember him saying, "Iraqi Security Forces in the city equals win for us" and that wasn't really the case when we inherited the battle space at all. When we inherited the battle space, they weren't doing anything and there was no partnership, mainly because no one had made them do anything. We were sort of trying to do things for them and the common theme that we heard was, "We don't have enough Iraqis to get them out and the ones we have aren't good. We need different ones and we need more of them."

So we just started working with what we had, building relationships, and then incrementally implementing that plan to secure the lines of communication, because we had positions strung out all over the city that you had to fight your way to get to, particularly the Government Center. That is where Bravo Company was and then Charlie Company was up at something called OP Hawk which was by the Ramadi Hospital. These were really isolated positions and they were engaged in sort of survival fights with the surrounding area. So we had to connect those dots, expand the security posture; but first make a decision whether we could maintain them or do something different. We decided to maintain them and strengthen them, get better over-watch of the routes, because of the IED problem in the city.

We had inherited a situation where there were about 90 IEDs suspected at any given time in the battle space which was only about four clicks by three clicks. So we had push pins on our map representing all the known and suspected and reported IEDs, and there

were scores of them. So basically you had no go areas, because we didn't have friendly positions in there and there was no way to find and clear every one of those. There was a change in perspective from the first time around, because when we deployed to Fallujah in 2005, if you knew or suspected there was an IED anywhere in your AO you'd send somebody out there to clear it, but this wasn't the case; you just dealt with the fact that if you were going to go somewhere you better clear it first. So that route clearance mission was a development that we didn't see the first time through, but it was there. They called it 'Dagger' when you'd send the Route Clearance Platoon out to clear a route with a Buffalo and the MRAP [mine resistant ambush protected – a vehicle for moving people].

Knarr: Who conducted the route clearing for you?

Zappa: There's a Battalion, an Army Battalion that was, I don't know the command relationship with the MEF, but basically it was in direct support to the Brigade, and so the Battalion would have to request days in advance route clearance missions, and the OPSO, Major Rob Hancock, he would schedule that through the Brigade OPSO and say, "I want route clearance missions on these routes, on these dates" and that was the only way you could really move around in the AO with vehicles.

Knarr: You didn't have a Platoon assigned to the Battalion?

Zappa: No we didn't. It was Army; they were Army Route Clearance Platoons that would move through the AO. And we would provide security with our Weapons Company for them. That was a mission that evolved, because we tried some different techniques of providing security while they moved through the city, including parallel mounted patrols, but we had mixed success with that.

Knarr: You mentioned positions that were already set up. So you already had a position at the Government Center and at Hawk when you got there, those were the two locations that 3rd Battalion, 8th Marines (3/8) had already set up?

Zappa: Yeah, they were. There were some OPs that were associated with those, like the Government Center had an OP, I'm going to speculate here, but I believe it was called OP Horea, that was down Michigan that over-watched check points 296, which was by the Saddam Mosque. In theory that helped connect Michigan from Hurricane Point through to the ECP on the east side of town where our adjacent unit was located. There was another unit to the south of us that had the race track south of Michigan.

Alford: 3rd Battalion, 7th Marines [3/7] was the first to establish that.

Zappa: That's right, yes Sir. Phil Lash I think was the Company Commander down there.

That was about a year before we got there. So that, Horea went with Bravo Company, and then Hawk had a position at the Ramadi Hospital as well that they maintained, but it was mostly Iraqi Police of one variety or another, Provincial Police that were supposed to be there. But when they suffered some casualties they pulled everybody out; so that post was stood down for the most part.

Then Alpha Company had something called the Snake Pit. The Snake Pit became JCC for us, Joint Coordination Center. Alpha Company inherited a couple positions there, but eventually that went away. We brought them back in and then they went to 17th Street Security Station. That was our first major offensive operation in the city. That was October; right around Halloween of '06 and that was when Alpha Company leap frogged up 17th Street to try to dominate the western part of the race track and fire cracker checkpoint. That was kind of like our big leap forward.

We spent the next several months consolidating that, because we built a new police station that we called the Western Ramadi Police Station. That was the one where we had actual local folks standing up, joining the IPs, and they manned that position, patrolled their own turf, their own streets; I mean it was their tribal AO, they knew it. Getting them paid, getting them professionalized was Lieutenant Colonel Jurney's big push for the first several months. Then we sort of consolidated all those positions up to the race track, or up to 17th Street while we just held down the fort, the Government Center, expanded security there and continued to move from west to east.

Knarr: Now you, what were your responsibilities?

Zappa: As the XO? First and foremost I went in with the understanding that I was going to be the Battalion Chief of Staff. Whereas the OPSO would own for the most part the two and the six, I would make sure that the four was in line with the three and the S1 obviously, and just run the rest of the staff. That's sort of the Chief of Staff primary job of the XO.

When we started training up for the deployment at Mohave Viper the Battalion Commander pulled me aside and said, "You're going to start running this non-kinetic effects meeting." The responsibility is basically a three function just like kinetic effects are but often times it falls by the way side because it's not given the level of importance as kinetic. And so he said, "I want you to sit over this committee and bring in Civil Affairs and Information Operations." We had an Artillery Liaison Officer 2nd Lieutenant

who was down to the IO course, a tactical PsyOps team that we were going to get from the Army; Civil Affairs, Public Affairs and then the H&S Company Commander and the Weapons Company Commander and somebody from the OPs Shop as well. Initially we thought, it was just like fires, we're going to run this like fires, it's a Weapon's Company function. That role sort of went away when we were training up at Twenty Nine Palms and we were able to put in effect for the MRE, the Mission Rehearsal Exercise at Mohave Viper. But it was mostly done through the H&S Company Commander and we would schedule what we planned through the OPSO to make sure it got the support from the Line Companies.

When we got into theatre, and we already knew that the unit before us didn't put much effort against Civil Affairs or Information Operations. They didn't have the command priority for it and the battle space may not have been as receptive, whatever reason, it wasn't being done. And so we quickly saw an opportunity to get small tactical victories out of Civil Affairs, because once you brought in the OPSO, I mean the last several months he would be at this meeting as well, and he would, "Ok, we can do this on this date. We'll make sure that we task this Company with security, we'll do it in this AO, etc., etc." Then we were able to prioritize the softer functions.

Then we also did a lot of brainstorming on the current problems, like what are we facing here, what's our number one issue? And clearly our biggest problem was we were not able to get our message across to the population. And when I say our message, I mean it's the Iraqi Government that we're there to support. One of the major lines of operation was to support and be an advocate for the Iraqi Government, legitimacy of the Police Forces and the Army. We had no voice for that, so we would use what we could, there were some cheesy IO products that didn't really apply to our AO that we would get that were always too little too late, the wrong message, that kind of thing, so we'd try to make our own stuff. We also brainstormed how we could get that message to the people, to the population and who would empower to get that across. And actually Adel [Abouhana] who was our translator, who you've met, was a very important person on this, to come to this meeting too, because he had a good awareness of your Arabic community, the Middle Eastern mindset, what would be effective, what would be legitimate, what wouldn't; and so he was very key for helping us get that message across. There was a fellow named [Tiley Nunnick] who was our, he was at the war fighting lab... [17:49]

He came up with the initial idea in this forum to broadcast a message to the population saying, "Thank you for the information that you're providing on the insurgents," basically to try to plant some seed of doubt in the insurgent's mind, that there was somebody out there that was informing on him. And it sort of evolved into, and we talked a lot about how to get this plan in action at this meeting, and Scott Kish who was our Civil Affairs Officer, he's another one I would recommend talking to...

He was our Civil Affairs Officer and he was remarkable, just a go getter, just a fantastic person to have. He looked for opportunities to exploit the CERP [Commander's Emergency Response Program] project money, you know anything he could get his hands on to try to get out into the town, but also to make sure we had the right message behind it, make sure we were backing the right people, which at that point was anybody who was willing to work with us. We started with little projects and go forward. We started with, "Can we find somebody who can haul off all the burned out vehicles in this town, and pay them, just to get rid of them, get them off the street?" That was big, Colonel Jurney's idea; that was the first thing that we did. We couldn't find any contractors that were willing to do it until we found this guy. He was still with us when we left, when the units that relieved us took over. He was still the man to get work done in that town, because he was willing to take risks and go out there without us providing security for him and he would work.

But, back to Major Nunnick. His idea was to try to legitimize and broadcast this message, like give the population legitimate information, you know soccer scores, weather, stuff you can get off the wire, unclassified source, open source reporting on news and try to not to be confrontational or controversial, just get this information out there.

And then we were able to get some mosque speaker systems like the ones they put on the mosques to do their call to prayer. We put those on the Police Stations that we were building and then Adel would work with one of the strongest police officers who was willing to have his voice carry the message to the people. To broadcast this thing, and see what happens. It was great! If you ask me, that was a huge force multiplier for putting forth our plan, because the Marines would go out with the Iraqi Police and they would go into these houses, and the people in the houses would say, "You're him? You're the guy from the message? Oh, wow, we're so glad you're here, we've been waiting for you!" And then as we put new positions up we'd buy more of these systems, we'd record them, make them MP3 files, SIPR Net them out to all the positions, play

them simultaneously and he had our message resonating out, including music, popular music, we had video of people dancing in the streets to the music; it was good. I think it was one of the major high points of our, for that non-kinetic plan.

Knarr: I've heard of the voice of Ramadi, who is that and what is that?

Zappa: We did it three days a week, it was a guy named Colonel Salam. He was just a fire breather. He was awesome. The Governor of Anbar Province brought this guy forward to us through the Battalion Commander and said, "This is someone who you can build security around" and so we empowered him. Really he had the initiative to go anywhere and do anything, and so we bet on him. Adel worked with him on his speeches, eventually he was attacked and killed by a suicide vehicle in February of, I think it was Valentine's Day of '07, but for four months or so he was the guy, he was the voice. Adel would actually read a lot of the news and the sports and things, and then he would say, "And now here's a message from the Chief of this police station." There were other opportunities. When he was killed his successor stepped right forward, Ahmed, Colonel Ahmed who, as far as I know, is still in charge of that police station in that area; he was as of a year ago. He became the new voice and sort of continued Colonel Salam's legacy.

We also used it for a demonstration. There were hundreds of people out in the streets with signs and we didn't know what was going on, and we determined that someone had spread some gossip that Americans had detained a female and they'd taken her from her home. So all these people were in the streets, clearly a ruse from the insurgency. We drove around until we got some Sheikhs, we got the Mayor of Ramadi, Latif; I went to Sattar's house and got Sattar's brother and one other Sheikh to record a message that this claim was bogus. And we got this thing recorded, piped it out, broadcast it and people went home. So, the effect was clear.

Knarr: What police station was that? You said Salam and then Ahmed.

Zappa: West Ramadi IP station is what we called it. It was right around Michigan, western part of the city. I can't remember the cross street, but it was close to the Governor's neighborhood where he lived. The Governor had his own little security detail that protected his neighborhood a couple streets over. And Smash was the name of that street, Smash. And the West Ramadi IP station was another, I don't know five hundred meters down the road from Smash. That was the one that we had the most confidence in because it was populated by police from that neighborhood, or from the city. The police

that we had, that were at the bigger stations that really didn't do much were not necessarily from the city, they were from some of the other neighborhoods outside. And so, we were looking to get people from that city. And once we did, we were able to leap frog across the city. Once we really got some things going, April time frame it just steam rolled across the city and it was like night and day.

Knarr: The other non-kinetic actions that you guys took?

Zappa: Let's see, Civil Affairs, all the companies would do Civil Affairs to one degree or another. H&S Company did quite a bit. Sean Dynan was the company commander. Additionally, all the companies, basically created internal MiTT [Military Transition Teams] teams to allow the MiTT team to focus on Battalion level training and organizing and for operational matters and logistic, not getting these guys to point their weapons in the right place and stand post and things like that. That was left up to the partnered companies. Dynan had West Ramadi IP Station. They were the most active guys. And he had one of his Lieutenants live down at that station with them all the time and he basically became another IP. I mean there were eight of them that lived there all the time, they had communications, a couple vehicles so they could move around. He was their advocate for operations and for when they needed more concrete barriers, or if they wanted to do something he would make sure that he got the word back to Major Hancock, "Hey, these guys want to go out tonight, this is where they want to go." We had people out there wanting to shoot things that moved at night so we need keep track of where people were, so he, this was the way they coordinated things like that. But Dynan had some ideas like putting white, huge whiteboards up at the ECPs, and so while people were going through the search lanes they could write things up as they were happening to kind of provide information to the people coming through, real time stuff, you could post your IO products there...

Knarr: Adel, Col Journey's interpreter, talked about that.

Zappa: Yeah. That was a great idea!

Zappa: But he also, they would go out and put Iraqi flags out in the city, hang them up. There were a lot of initiatives like that. I also think that the way we handled Public Affairs and embedded reporters, making sure that we influenced what was being written about Ramadi was important, because one of the key audiences is the American people, the American population. And when we were back home, before going over there, all we heard about was how horrible a place it was. You know, every single story about Ramadi

was that it was under siege, shooting every day, we're dropping bombs in the city. That lends itself to, "Holy hell, what are we going to see when we get in there; enemies ten feet tall?" that word gets down to Lance Corporals really fast. Then when we got there in the PDSS we're like, "Ok, it's bad, but it's something we can fight. But, we wanted to make sure that we weren't contributing to that perception that Ramadi was under siege, even if it was bad we didn't want the word getting out about how bad it was, because that was self defeating. Basically you're contributing to the enemies IO Campaign by giving them what they want, which is the perception that the town's under siege. Then they can use that as a force multiplier. So, we tried to shuttle the ones who came down to us to things we wanted them to see, things that would be better for us if they saw, which is like the partnership at the ECPs or the Civil Affairs projects or the meetings with the town people, you know the District Governor, or the District Representatives, and stuff that was getting our message out vice others. Once we got everybody on board we were much better off.

Knarr: Good. You've already talked about who we should see you know Iraqis, it sounds like Mayor Latif; it sounds like Colonel Ahmed who replaced Salam.

Zappa: Yeah.

Knarr: Probably Mamoun who was the governor. Who else did you, what Sheikhs did you work with besides Sattar?

Zappa: Well I knew Sattar, I saw him, because I used to go to his house all the time. But I knew his brother well, his brother Ahmed who, he's in charge of the whole thing now since Sattar was killed. I always thought he was kind of the brains behind the operation anyway.

Another project was rubble removal. I don't know if you've heard about this but Civil Affairs at Brigade and MEF level had this big "Rubble Removal Project" because they had leveled blocks and blocks, basically cleared fields of fire out in front of the Government Center, from all the engagements over the years and the buildings were all destroyed. So Engineers came down and blew them all up. And so for several blocks north of Michigan, in front of the Government Center there were just, there was rubble, several story buildings that had been dropped. And there was a Civil Affairs project to remove it, but nobody was executing it. And so we started talking to Ahmed about getting that project done and he said, "Yeah, I can do it" and Hickman was an Engineer and he, well he brought him to a meeting with some of the Brigade Civil Affairs folks.

Jason Arthaud was the Company Commander of Bravo Company at the Government Center, we made sure, we lined up the security with him to make sure, because these guys are going to provide their own security, provide their own dump site, roll in and pick up all this rubble and get it out for a couple million dollars or something; so we brokered that deal through Ahmed and Hickman and they executed it. And that was pretty impressive. We tried to publicize it, "Hey look we're cleaning this place up. There's going to be a park here someday"... But besides those guys, Sheikh Raad, Raad was the guy who removed the burned out vehicles. Once he did that we started going to him, he said, "I can do more. What do you want to do? Let's build some schools, let's fix some roads, let's fix some stuff at the hospital." We would go out and meet him and he would show us things that he was doing on his own and we, that helped get some projects going.

Knarr: What tribe was he with?

Zappa: He was Albu-Alwan.

Knarr: Ok, he was the same as the Governor.

Zappa: Same as the Governor, he actually lived on the same street as the Governor and was on the Provincial Council as well. We got Raad through a guy named Saad, who, Saad was a contractor who had worked with some of the units before us. He kept a room at the JCC where he would stay for, because his, he was getting life threats on his family. All these guys lived within that West Ramadi IP Station influence, they lived in that neighborhood.

Knarr: Was the JCC near the Government Center?

Zappa: No, it was right across the street from Hurricane Point, right as you come across the bridge from Camp Ramadi it would have been on your right. It was what the Snake Pit had been, which is also where Marines had lived in the past. It became sort of the place to go to have meetings and the Mayor kept his office there when we were there.

But, Saad was a contractor who was able to do small things. We used him a little but, through him we met Raad and the Raad sort of exceeded what Saad could do. I don't know if there was some internal politics between them, but they had a hard time sharing power. At one point they were at each other's throats so I said, "Hey look, why don't you guys meet me at Sattars house?" and they said, "Alright." So we met out at Sattar's house and we're sitting in the room and everyone's tense and Sattar walks in, because I

had talked to Hickman, I said, “Hey look, can you help me smooth this thing out?” Sattar walks in, starts cracking jokes, brings these two guys together and makes them hug, and then the problem, and then he’s like, “Hey we’re going to all work together right?” and they were able to actually talk through the issue, we got a workable solution and we used that venue to fix the problem.

But, Saad lived in that neighborhood near the West Ramadi IP station. He used to invite us over for dinner, we would go have dinner at his house, sort of cement that relationship. He was a good guy. Other Sheikhs started coming out of the woodwork. Once we increased the security posture in their little neighborhoods the smaller Sheikhs would, all of a sudden, start to come up to the Company Commanders like at the 17th Street Security Station, Kyle Sloan who was Alpha Company Commander, they would, all of sudden people were knocking on his door and wanted to talk about projects in their area, which was unheard of leading up to that.

And then we worked out a District Council, we tried to get representatives from all the different neighborhoods that we had in our battle space to agree on how to do contracting, get basic services going, where the police stations were. That was going to plug into the Mayor and the City Council so we’d have a representative from our district on the City Council. I just kind of inherited this job to be the District Council organizer for our area. I mean I didn’t know anything about parliamentary procedures or how to do City Council, City Government work but it sort of fell into my lap.

We were trying to do some things like that to get the ball rolling when I was, when we were getting ready to leave. But it was very interesting to watch them hash out their own little politics at the grass roots level. The misconception was we give these guys freedom and they’ll know what to do with it. They really didn’t know what to do with it. They didn’t know how to organize. They were used to thug tactics, the strongest one will tell everybody else what to do, you don’t need to build any type of, they don’t need to build any consensus on anything, we just, “I’m in charge and this is what we’re going to do” and so they had to learn that. And that was challenging. But, that was something that I just kind of inherited as a, “Hey you should; you’re going to do this, because there’s nobody else that’s going to do it”.

Zappa: [Discussions about 3rd Battalion, 7th Marines returning to Ramadi to replace 1/6. 3/7 was in Ramadi in 2005 and 2006.] Yeah, he [Lieutenant Colonel Roger Turner, Commander 3/7] was able to connect the file between us and 3/7. I give them a lot of

credit because that Battalion had to have the right mindset coming in and they had just been there, so they had a lot of Marines who had been in Ramadi when it was a different place, and so to appreciate you didn't have to go back through and re-clear it, alright, just, because there was some people with that mindset. It was like, "Hey, I didn't clear this, so I need to clear it. I can't just let somebody give me battle space without me doing it."

There was actually a time when 2nd Battalion, 5th Marines [2/5] who had come as part of the Surge, they were one of the Surge Battalions, they took over southern part of the city south of where Task Force 1-37 Armor had been. I was at Sattar's house for some other unrelated thing and I look up and there's this mob of Iraqi men walking towards me all excited. Because he, Sattar was at the front of them and he's like, he looks at me and he says, "Major Zappa will help you" and I'm like, "What's going on?" I didn't know any of these guys and Adel and, oh Hickman was there, Hickman's like, "They want to start a police station in their area. They say it's in your area." I'm like, "Show me, tell me where it is", well it turned out it was south of Two-Niner-Five checkpoint down along the river in 2/5's area. I said, "Ok. I don't own that area. It's not my area, but, I need to talk to somebody." I said, "Let me talk to some people and let me see what I can do" because I didn't want to tell them I was the wrong guy for the job. I wanted to be like, "Let me see what I can do" so I went, got on a radio, relayed through our COC to talk to 2-5 and say, "Hey, these guys want to do something, And they want to do it right now. They want to tell all their guys to put on glow belts and stand on the street corner and kick all the bad guys out" and 2-5 came back and said, "We'll meet them at the JCC and talk about this."

So, we got in vehicles and went down to the JCC, these guys met us there, and 2/5 was fine with it, but they had a mission planned that they were going to go through that area and they were going to clear it out themselves first. They said, "After we do this, then you can do your OPs." The Iraqi's are like, "No. There's no reason for you to do this. We're going to do it." The resolution was they did an abbreviated portion of the clearing operation knowing where these guys were, which was a little hair-raising.

I can appreciate why they wanted to do it. They didn't know these guys, they could have been anybody, but I think they ended up going through it with some type of hybrid plan to clear it with them.

25 January 2011

Subject: Interview with Captain Scott Graniero, former Sapper Platoon Leader, 1/6 Marines

Captain Scott Graniero was formerly the Sapper Platoon Leader for 1/6 Marines in Ramadi from September 2006 until March 2007. Captain Graniero was responsible for constructing the combat outposts (COP) within 1/6 Marines battle space in Ramadi.

Captain Graniero was interviewed by Dr. William (Bill) Knarr at Camp Lejeune on 12 January 2010. The following is his account, from a combat engineer's perspective, of events that took place during his deployment to Ramadi.



Dr. Bill Knarr: First of all provide your background, who you are, where you're from, when you came in the Marine Corps.

Captain Scott Graniero: I'm from Jacksonville, NC. My father is a retired Chief Officer V, retired back in 2009, so I pretty much grew up in Jacksonville. I went to school at the University of North Carolina at Pembroke which is about 34 minutes south of Fayetteville off I-95. 9/11 and OIF-1 kicked off when I was still in college and there was no doubt in my mind that I was going to join the Marine Corp. So I went to the Officer, Selection Officer up in Raleigh North Carolina and did my PFT and signed the dotted line back in October of 2003.

I went to OCS in June of 2004. I graduated in August and then I was commissioned as second lieutenant and I went immediately over to The Basic School over at Quantico. I graduated from The Basic School in March of 2005 and then I reported to Marine Corp Engineer School, Camp LeJeune North Carolina in 2005 and graduated in July. From there I reported to Second [Commandeer] Battalion as a second lieutenant and immediately when into the S4 Shop. When I was at TBS the word was that as soon as you get to your unit you're immediately going to pick up a platoon and deploy out, so I was anticipating immediately taking on a Platoon and going to Iraq. I actually spent about six months working as the S4 Alpha till about February 2006.

That's when I picked up my first platoon and began training for preparation for deployment.

Knarr: When did you find out you were going to take an Engineer Platoon?

Graniero: I found out probably in February 2006. The boss brings me in, tells me I'm going to be supporting 1/6 Marines; he says I'll be taking over another Platoon that just got back from OIF and that I'd be keeping about 15 of those guys and then I was able to pick out whoever else I wanted to go on deployment with me because there was not another Platoon deploying out for about another six months. So, luckily for me I actually had the pick of the litter when it came to Engineers within the Battalion.

There's an Engineer Training area down in, called ETA3, Engineer Training Area 3, which is kind of like the school house for 2nd Combat Engineer Battalion. It's a large training facility that 2nd CEB actually owns and does a lot of training out of. And there was a lot of instructors down there who 1371 [military occupational specialty, MOS for Combat Engineers] Engineers, that wanted to go on another deployment so they volunteered and came with me.

I had a solid crew of Squad leaders, I had solid Staff NCOs, both my Gunny and my Staff Sergeant were very proficient in their duties. So I was very lucky as a Platoon Commander, especially being on my first deployment, that I had robust experience and knowledge within my Platoon. So when we got over there a lot of the learning curve was quickly learned because I had Marines there that had been to Iraq, some had been in Fallujah back in 2004 during Operation PHANTOM FURY, so there was a lot of experience and I learned a lot from those guys. It helped ease the learning curve.

Knarr: I'm not sure about the organization of the Marine Corp Engineers, so you were part of 2nd Combat Engineer Battalion, Charlie Company, 1st Platoon. How many people are in a Platoon?

Graniero: Normally about 27. When we look at the table of organization, normal TO of an Engineer Platoon you have about four or five Engineers in your headquarters section. That includes your Staff NCOs, the Gunnery Sergeant who was my Platoon Sergeant, and you also have a Platoon Guide which is normally a Sergeant or Staff Sergeant. And then I had about three guys that were drivers and were kind of like tool room NCOs. They basically did administrative functions. And then I had three Squads of 1371 Combat Engineers. And a normal traditional Squad is about nine Marines. So, for 1371's within my Line Squads, I had 27 Engineers. And then when we deploy out, we task organize with a support element that includes heavy equipment operators that can operate our heavy equipment. I also deployed with one heavy equipment mechanic, one electrician, and two Motor-T operators; they could drive our Motor-T assets like our

seven ton vehicles and I also deployed with one corps man [combat medic], and also one radio operator, one radiomen.

Knarr: How many people all together then?

Graniero: All in total was 41 Marines in my platoon.

Knarr: What kind of equipment did you have?

Graniero: For heavy equipment we fell on a lot of the gear when we got into theatre, but we had one Tram, which is a forklift. It can either be a scoop loader, a front end loader, or it can actually change out its bucket and put on forks and be a fork lift. It's probably the work horse in the Marine Corp. It's probably one of the best pieces of gear that the Marine Corp has ever bought. We also had a couple smaller dozers like the 1150, which is a smaller dozer, not as big as a D-7 and it really didn't have any armor, so it didn't have a lot of capabilities. I couldn't use it out in the city. [Figure 1. Equipment]



Figure 1. Tram, D-7 Dozer, M88 Recovery Vehicle, Courtesy Capt Graniero

I also had what's called a SkyTrak MMV, which had a telescopic boom. It's a smaller forklift, but the good thing about the MMV is it can get into smaller places and it had an extendable boom on it so I could actually boom out to about 40 feet and approximately 40 feet up in the air. So when we actually started building some of these OPs, if I couldn't use the CB's [Construction Battalion or sometimes written as Sea Bees] 40 ton crane and support, we actually used the MMV to help us lift things on top of the roofs like sandbags, bunker material for building the bunkers and a couple other things. So, it worked out very well. Then we also had about five M-1114 HMMWVs and two seven ton trucks, one dump and one regular flat bed.

Knarr: Ok. You talked about Mojave Viper going through your RCAX [Revised Combat Arms Exercise] or your pre-deployment training a phase. When did you go to that? Did you go with 1/6?

Graniero: Yes Sir I did. About half my Marines actually had just gotten back from OIF. This was back in February. So they went on about a month long post deployment leave period and by the time they got back; this was probably April 1st, is when we actually began training as a platoon. So I had the entire month of April to train my Marines in preparation for Mojave Viper, which we left for in the early part of May. So, we used that time period before Mojave Viper, that one month, to actually train. It was my objective as a platoon commander to show 1/6 battalion commander, Lieutenant Colonel Journey, that my engineers were proficient on anything engineering, and oh by the way we can also shoot, move and communicate just like his grunts. That was one of the things we stressed upon that first month as the platoon was doing the crawl, walk, run method of training starting off with the basics, building that foundation. And then by the time we left to go to Mojave Viper we were well trained to do whatever 1/6 needed us to do in support of their CAX's Mojave Viper.

Knarr: So you during Mojave Viper what kind of training did you do? How did you then train to support 1/6 at Mojave Viper?

Graniero: Well Sir, April is when I actually started working with the staff elements of 1/6, and in particular Major Hancock who was the Operations Officer. I started working with him a lot on their planning for Mojave Viper. As an example, what were some of the ranges they would be going on? Like Range 400, 410 Alpha, which were platoon and company level size assaults. So what I did is, is I looked at engineering requirements. Like at 410 Alpha we had to create a breach, so I knew that my Marines had to be proficient in demolitions, they had to be proficient in breaching with Bangalore or APOBS. APOBS stands for Anti-Personnel Obstacle Breaching System which is like a smaller MKLK that fits in two backpacks. So my Marines had to be proficient on that. So I looked at everything that 1/6 was going to do and how as an engineer I was going to have to support them, and I wanted to make sure that my guys were properly trained up on that. So that's what our focus of effort was prior to us actually leaving to go to Mojave Viper.

Another thing that we did when we were out at CAXs was, we actually conducted a mechanized breach with tanks and Amtrak, or AAVs in support of 1/6 on what was called a Delivered Assault Course. What I had to make sure was my guys were proficient in obstacle breaching. So we broke it down to fundamentals, redid the breaching tenets, going over breach fundamentals of SOSR which the Army and the Marine Corps do it a little differently. In the Marine Corps we called in SOSR 'R',

which is Suppress, Obscure, Reduce and Re-supply. While as the Army goes, SOSRA which adds the 'A' which stands for Assault. So that's the difference between the Army and the Marine Corp. But, we also trained on going out there and doing breaches with our heavy equipment, being able to breach a berm, being able to breach an anti-tank ditch. So those were all things that we focused on in preparation for Mojave Viper and some of the things that we were going to be doing out there.

Another big thing that we trained to was building that relationship between my squad leaders and the company commanders they'd be supporting in theater. One of the things that Colonel Jurney and I worked out for the deployment was to keep my platoon in general support of the entire battalion. This worked out very well because I was able to mass my engineers for a particular operation or mission, or I could task organize them and attach them out to a line company to go and support them on a cache reduction or on a patrol or any kind of thing that they needed engineer support on that didn't require my entire engineer assets. So, I loved being in general support because it gave me the ability to do my own missions and provide my own internal security. I was able to do multiple missions within one giant mission, because I had the assets available.

Knarr: Did the training work out the way you planned it?

Graniero: Yes, Sir, it did. Like I said, one of goals as a platoon was to go there and impress 1/6, to show them that we knew our engineering job and at the same time we could shoot, move and communicate just like them. That was the whole purpose of our work up prior to just going to Mojave Viper. While we were at Mojave Viper, in my opinion we did a very good job for 1/6, there was nothing but good comments that came out of it from, not only the Coyotes who ran TTECG [Tactical Training Exercise Control Group], but we also got good remarks from 1/6's battalion commander. So, that was our mission, that was our focus and we did a very good job of meeting that mission.

Knarr: Would you have done anything different in training in hind sight after a tour in Iraq, as you look back on it, did that training support what you did in Iraq?

Graniero: Actually Sir, no. I know this is back in 2006 and Mojave Viper is now called the Enhanced Mojave Viper and it has gone through a world of changes since I went back in 2006. So, over the past four years they've started to become more focused on up and coming TTPs vice the old style, because when we were there Range 410 Alpha, 400, those were platoon/company assaults that my engineers were supporting with breaches;

that was stuff that we really didn't do when we were in Iraq. Breaching and the MKLK were not used in once we were in theatre.

One of the things that was beneficial was called UWTC, Urban Warfare Training Center that was right there at Mojave Viper. It was a two week long construction that was kind of like the final exercise for the battalion. And during that time period my guys actually were able to go in there and build an OP, which was probably the best training my guys had there, because that is actually what we were doing a lot of when we got to Iraq, was building OPs.

So, looking back on it was very difficult to do some of the training to prepare us for deployment because it came down to materials, it came down to class four materials, finding a building similar to what we would find in Ramadi and actually go and fortify it. You really just can't do that anywhere. The only thing you can do is just make sure that you understand how force protection works, know the materials that are available to you and know how to emplace them, i.e. know how to properly emplace HESCO because if you don't properly emplace HESCO you're going to have the HESCO fall over or not provide the force protection you need. So those are the things that we focused on to make sure the guys properly knew how to emplace it vice actually going out there and building an entire COP. Because we just didn't have the material or the area to do it.

Knarr: So you finished up in May, it was mostly Mojave Viper, so you're into June...and then you deploy in September.

Graniero: Yes Sir.

Knarr: Ok, so then of course Block leaves, what else did you do during that pre-deployment? Did you go on a Pre Deployment Site Survey [PDSS]?

Graniero: No Sir, I did not go on a PDSS. I actually, looking back on it I wish I would have gone to PDSS, because of the amount of engineering operations that were going on during that time period. The big one was the leveling of all the buildings across the street from the Government Center. That would have been very good information for me to have known. And also I could have gone and understood the concept or understood the structure of the Army engineers and how they were able to support us. Because that was something that I didn't quite grasp until I actually got there to Ramadi and was able to walk around with my peer, the other engineer that I was replacing and

actually get introduced to the guys of 16th Engineers and the other engineer elements that were there to support 1st BCT/1st Armored Division [1AD].

Knarr: So when did you get to Iraq?

Graniero: I was able to go on the advanced party for 1/6. Colonel Jurney's intent was for all the commanders to go forward on the ADVON so that way we could spend the two weeks before the battalion got there in theatre to talk to our counter parts, get to know the AO, get out there, see the lay of the land and prepare ourselves before our Marines actually got on deck. That was great, because I was actually able to go out on missions with the engineer platoon commander that was supporting 3/8, a gentleman name Lieutenant Ben Clay. And Clay was the one that introduced me to all the Army engineers. He helped me understand the structure of the Army's engineers and also some tricks of the trade like utilizing the PLS vehicles, the Palletized Loads System vehicles, how to emplace barriers on them, offload those barriers. Those are all things that we didn't have the capability of learning back here in the States because we just didn't have the material to do that training. So those were things I got to see firsthand, got to experience and then I was able to prepare myself before my Marines actually got on deck. And that way I was able to teach my Marines and we were able to go out there and immediately begin operations in support of 1/6. It worked out very well for us.

Knarr: Did you move right into Camp Ramadi?

Graniero: Yes Sir, I did.

Knarr: Ok, because 3/8 I guess worked out of Hurricane Point.

Graniero: And so did 1/6.

[On the map] Up here Sir, this was Hurricane point. I'm going to draw it first what it was like back in August of 2006 when we were RIP-ing out with 3/8.

At the time, this is Hurricane Point, and this is where 3/8 Battalion Headquarters was at, located. They also had their Weapons Company, which was their MAP Platoons, their Mobile Assault Platoons, located up in here and also the one lone Tank Platoon that was attached to our battalion from the 1st BCT/1AD. So you had a platoon of tanks up here at Hurricane Point, you had the Weapons Company and then you had all your other cats and dogs like your Communications or Signal, you had your S-3 Shop, your S-2 Shop, all that stuff was located up here.

Now the remainder of your logistics elements like your engineers, your supply, your Motor-T, all that was down here at Camp Ramadi. And then you had Marines here at ECP South, you had Marines up here at ECP North. I believe, this building right here, this was called OP VA. You had the Gov Center which was right in here. And then you had Check Point 296 was right in here, I want to say this building right here because I believe this is the cemetery. I think this building right here, it's hard to tell on this map, but this was OP Hurriyah [also called Horea]. [See Figures 2 and 3 for orientation]

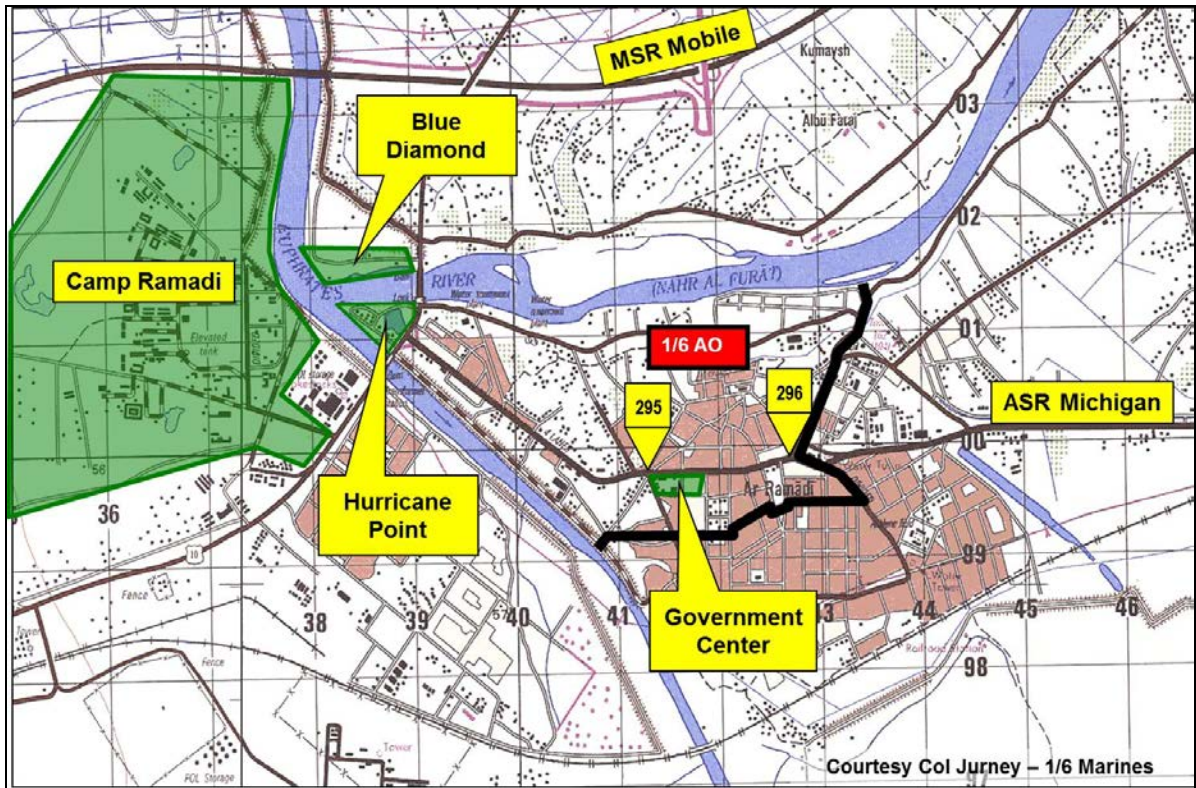

Figure 2. 1/6 Marines Area Orientation

And then, way up here was OP Hawk. And that was the lay of the land for 3/8. So you had your logistics, your engineers down here in Ramadi, you had your battalion headquarters up here in Hurricane Point, you had a company at OP VA, a company at the Government Center, and then I believe that company from the GOV Center also had OP Hurriyah, and then you had another company up here at OP Hawk. That was in August of 2006.

By the end of our tour, when we RIP'd out with 3rd Battalion, 7th Marines [3/7], out of Twenty Nine Palms in May of 2007, this grew by a lot. And I'm sure you've probably

seen some maps of some of the OPs, but you know, over the course of time this is where we initially started, by the end we had OP 295, we had the 17th Street Security Station, used this building right here, this was OP Firecracker, and I think this building right here, was OP Race Track. This right here was Qatana Security Station. I believe it was one of these buildings up in here was OP North. Hurriyah was still there.

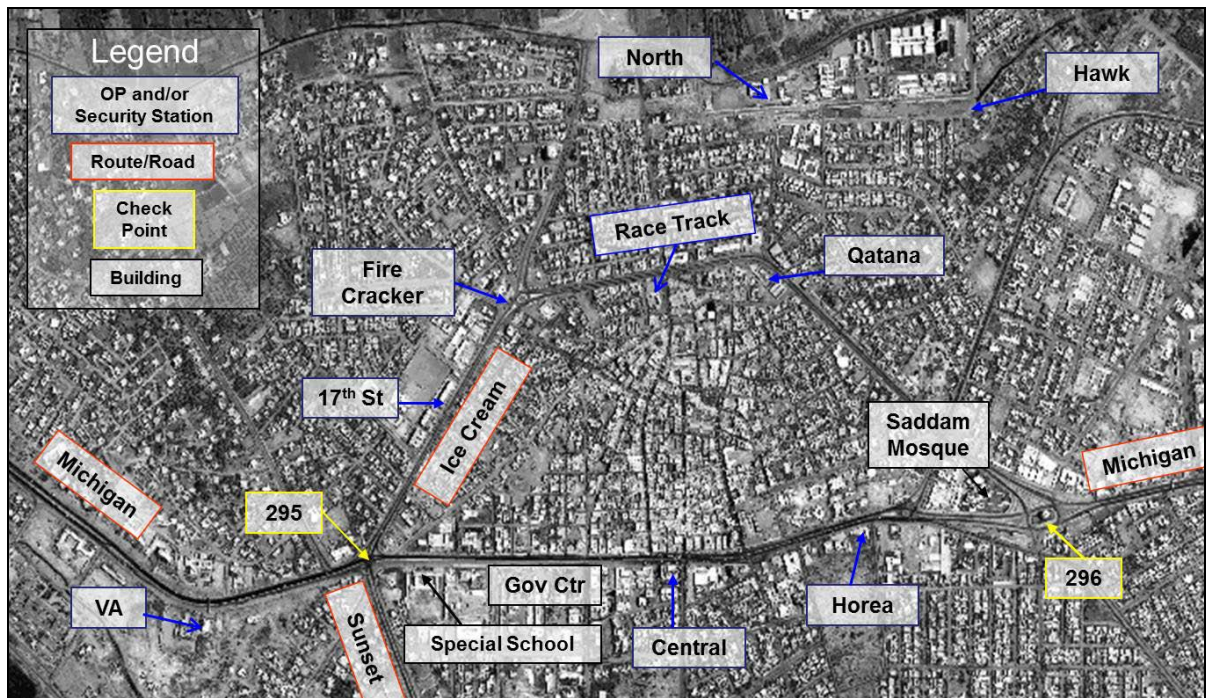

Figure 3. 1/6 Marines Landmarks

Knarr: 1-9 Manchu's [1st Battalion, 9th Infantry or 1-9 Infantry] was out there.

Graniero: Yes Sir. I believe when we first got there it was the 1st Battalion of the 506 [1-506th] and then it changed over to the 1-9 Infantry. Then we'd have to hit Michigan, travel to Check Point 296, which was always very dangerous, because you had this place called the "Finger Nail" down in here [little sliver to SW of 296] where there was no real good observation and they were always placing IEDs, and so a lot of times a lot of our vehicles were hit. And we'd keep traveling down here to 296.

Knarr: I stopped by there too. You called this the "Finger Nail". That's interesting!

Graniero: Because it was in the shape of a finger nail. Yes, Sir. The bad thing about the "Finger Nail" was that from OP Hurriyah we could not see this upper area up in here, and I want to say the Army had another OP somewhere out here.

Knarr: Hotel?

Graniero: Hotel that they could actually see a portion of it too, but they really couldn't see this bottom area down here, and because of that they were able to put IEDs out there. And some of the problems we had up in this area, and this all kind of tied in with the blowing of these buildings up in here, just a bad sewage system. A lot of time up here in the northern part was flooded out and they really didn't like driving vehicles to the flooded areas because it was easier way to hide IEDs. So we would always take the southern route, which was a higher elevation so it wasn't saturated as bad and that's where they placed the IEDs. But by the time our deployment ended in May 2007, we had grown from the area in blue to the area in black [essentially east of 295].

A lot of these operations were named after the island campaigns of the Pacific during World War II, like Peleliu and Tarawa and a couple of other places.

This area right here was called the *Souk*, the market place, and this is where all the bad guys lived, right here, all the insurgents, all the activity, all the reports and all the UAV feeds always showed the enemy either coming in or coming out of the *Souk*.

When we first got there, like I said, the areas in blue were areas that were already occupied by 3rd Battalion, 8th Marines. When 3/8 RIP'd with 1/6, one of the first things that Colonel Journey wanted me to do was to get better control of Check Point 295. Down to the south along sunset, OP Falcon, it was the 1st of the 37th Armor [1-37 Armor] I believe was down there, and every day they were sending resupply convoys back to Ramadi, they were getting hit with IEDs on 295. So it was one of the first things that we looked at, and this is actually the first test of the Engineer Platoon when it came to building OPs. We learned a lot from our experiences building this first OP here at the special schools, right here at the corner of the Government Center. That was our first OP that we constructed as an actual platoon.

We built up some good SOPs for the platoon on how to actually go out there and employ these barriers, both Texas Jersey and also how to build some of these OPs up so they'd be survivable if a VBIED hit. So, in terms of importance this one, a lot of lessons learned. This kind of set the stage, or set the standard I guess for our OP builds. The other importance of this is that it provided over-watch of Check Point 295, which whether you were coming from 1-9 Infantry's AO, or you were coming from Hurricane Point, any vehicle convoy that was traveling along Michigan was going to in some way, shape or form hit Check Point 295. So, by us putting that OP there and preventing the

insurgents from placing IEDs out there, you know, helped stabilize the AO, especially for us traveling down that route. So it was important to the brigade as a whole, building OP 295 was probably one of the bigger things that helped out with the brigade's AO.

Knarr: What kind of steps do you go through when in deciding you need to build a COP and in building the COP?

Graniero: I'll use this, the OP 295 as an example, first thing that we did was we, we looked at, "What do we want to observe?" We wanted to observe Michigan traveling from Check Point 295 back to Hurricane Point, wanted to observe some parts of Ice Cream, which is the road that was running northeast, we also wanted to observe some parts of Sunset, so we had to pick a building that would do just that. Which one was tall enough that it observed all these avenues of approach? Which one was a building that we could easily fortify and make it into an OP? So those are some of the first things we did in the mission analysis part of the planning process.

So, in this case right here, the school house that was right there at the corner was a three story building, it provided great observation down all these avenues of approach and at the same time it had adequate distance or stand off from actual Route Michigan. So, our biggest fear when we started doing our mission analysis on the enemy is, "What is the enemy's most dangerous course of action?" Well our enemy's most dangerous course of action was to run a VBIED and blow up one of our OPs. So, when we looked at it from the enemy stand point we had to make sure that our barrier plan to support the OP was pushed far enough to provide us adequate stand off so if it did go off it would cause minimal damage to the structure. But, we also had to make sure that our building was far enough off the road that it could still provide, you know give you some initial stand-off.

That was one of the hardest parts about being in a city, in an urban environment, is trying to get that stand-off. I can explain some of the ways that we achieved that, but this building right here, when you look at the grand scheme of things, it gave you the stand-off that you required from the main part of the road, and at the same time the building was so structurally sound, it was a large building and it provided us adequate observation down all these avenues of approach. So that's why we selected that building.

In developing the plan I would either I would look at a Falcon View picture, very similar to this right here, but blown-up to this area right here, or I would ask, or request of the S-

2 Shop to give me aerial imagery of this, real time aerial imagery. I would get on Power Point, or I would just get it in a picture format and I would print it off and I would sit there and say, "Ok, how do I need to establish my barrier position working from the outside in to defeat any kind of a VBIED or any time of small arms or rocket attacks that might happen on this compound right here?" So I would work from outside in, and I would draw my barrier plan out, very similar to the plans you have in that brief right there, I would identify how many barriers are required to give me adequate stand-off and to give me the force protection I required.

After I got done with my barrier plan then I would look at the physical security of the building. You know, did I need to lay triple standard [Concertina] wire out there to stop any kind of movement in and out of dead space, down an alley way? Did I have to deny any buildings that were right next to the actual building we were standing in that we were going to occupy to prevent any type of insurgents from getting inside that building and having small, or direct fire attack positions on our positions in that OP? So those are some of the things I had to be thinking about as I was actually going through and designing the force protection of this building.

The next thing is, is then I would look at, "Where on top of the building do I get the best observation?" On a lot of those Iraqi buildings, I don't know if you got an opportunity to get on top of the roof structure, but a lot of them have a wall that outlined the perimeter of the roof and a lot of times when you're building a bunker ideally you want that Marine sitting down all day long. You really don't want him standing up, because standing up for six hours on duty gets very tiresome. So when we designed these bunkers we designed them so that the Marine is actually sitting down. But if you design your firing port too low, then it's going to be obscured by that wall. So, we had to actually do all the measurements for that, make sure that the bunkers that we were building were going to be able to see over that wall and at the same time give that Marine a good firing position to be able to engage any kind of activity that might be happening out here in the AO. So those are some of the things we had to think about.

Knarr: I was at the 17th Street, so you're right; they had that wall around it.

Graniero: And then the last thing, when we came to the planning process, is we looked at from the enemy stand point, we looked at the force protection working from the outside in. Then we looked at the kind of materials we had available. What are my assets available to me right now that I can actually go out there and apply it to this building?

For instance, when we went to 17th Street Security Station, our bread and butter was the 40-ton crane that we were able to get from the CBs, but that was like pulling teeth, because everybody in all of Iraq needed that 40-ton crane in support of their OP builds. But, for this building right here, this is where we used that piece of equipment I was talking about, the MMV Skytrak that had the telescopic boom. This is where we used that capability to be able to lift sand bags and other building materials on top of that roof that way you didn't have Marines from the ground level passing sandbags through a chain gang all the way up three flights of stairs onto the roof. So it worked out very well for us and we were able to incorporate that into our actual mission.

We also had to make sure that we had enough trucks to support our operations, because that also played into my timeline. I think in this case right here I told the battalion that it was going to take me three days to complete. That's with the number of trucks I had in support, that's the number of barriers I had to place out there, and sometimes I didn't always make timelines, but I tried my best to make the timelines in the manner given. If I told the Battalion Commander it was going to take me three days to build, I was going to build it in three days. So I tried to live by those timelines and that was all based on the availability of rolling stock, lift assets, barrier material; that type of stuff.

So for my first OP build, a lot of lessons learned, we made a lot of mistakes, nice little gut check for us and we learned a lot that helped us prepare for our next OP build.

Knarr: What were some of the lessons?

Graniero: Some of the lessons learned involved the actual building of the bunkers. What I tried to do to kind of speed up installation time was to have these bunkers pre-fabbed. Now my guys were able to go out there and do a reconnaissance on this building prior to us actually doing any of the pre-fabbing or beginning on-site construction. The problem that we ran into was we pre-fabbed these structures, but we had no way of actually getting them on the roof. The MMV could boom up to a certain height, but we actually had to break the bunker apart into sections and then reload it on to the MMV and raise it up and then rebuild it once we got up there. So that was a lesson learned. We had to know when the 40-ton crane became available. With the 40-ton crane I could actually leave those structures together and lift it completely on top of the roof, but if I was using the MMV we couldn't do that because of the weight and the height restrictions. So that was one lesson learned. [40:30 S1]

The other lesson learned was when we were talking about moving the barrier material from Camp Ramadi to the Government Center. Originally, I think, in one night we were able to push out maybe 30 to 50 barriers. When it was all said and done, by the end of our deployment we were able to push out anywhere from 150 to 200 barriers and that's because we figured out the right solution to pushing out barrier material. The lesson from this one was that we had ten trucks in support, ten PLS, and on ten PLS's I could carry out either ten Jersey Barriers, or I could carry out four of the Texas Barriers. So originally I took all ten trucks out at one time. But I only had one TRAM to off-load that truck and I had another TRAM that was actually in placing. So I had a lot of trucks just sitting by waiting to be off-loaded and I couldn't get those other ones that had already been off-loaded refilled, because we didn't have it broke down that way. So for other operations what we did was we split the number of trucks that we had in half, five of them would be waiting back at Camp Ramadi already loaded the others would be up on sight getting off-loaded. As soon as they get off-loaded they would pass in flight and that way there was a constant off-loading and on-loading of barrier material. That kind of helped us speed up the process of getting barrier material out there in support of our operations.

And then the last one was some of the other force protection issues that we were running into. In this case down here we actually had a bunch of people living in buildings that were originally in my plan tied into that, the actual force protection plan. I was going to use these buildings, these structures as part of a barrier plan to our southern flank of the OP. But when you have people living in there that exposes your southern flank, and so we had to go in there and deny those buildings. And I don't know if we ever removed those people out of those buildings, but I know we had to go back and block those people from being able to come into that compound and affect any kind of operations that was going on inside the OP. So those are the three big lessons learned.

After OP 295, the next big OP build was out at 17th Street Security Station. Now 17th Street Security Station we built probably late October, early November of 2006. This one right here, this is where you would find, really interesting, it was a joint effort between Marine Engineers, Army Engineers and then Navy CBs, and we all three of us got together and we actually came up with the design for the 17th Street Security Station plan. This is when the gated community concept; I don't know if Colonel Jurney talked to you about that, this is when that plan kind of really came into effect. When we got into the mission analysis phase, we looked at the enemy, again our biggest threat was the

VBIED and we were afraid that a lot of the VBIEDs were going to come out of this sector right here, out of the *Souk* and try to attack us while we were actually building this OP.

[Some background] 1/6 basically broke two companies on both sides of Ice Cream, on the east and west side and worked from the south from Check Point 295 all the way up here to OP Firecracker, basically clearing every building and basically setting up OPs along the route to provide us over-watch positions as we were actually constructing the building.

In conjunction with that, I had PLS's loaded with Jersey Barriers and we came to every major intersection on both the east and west side of Ice Cream and blocked those intersections off with Jersey Barriers. And that prevented any kind of VBIEDs from coming from the *Souk* and hindering our operations up in here. What we had later on, and this is where the gated concept comes in, we later on blocked off every intersection all the way up here to Firecracker and we continued all the way on to this intersection right here where OP Qatana was going to be at, all the way down here to the south to almost Check Point 296. So basically what we did was we were able to control the traffic flow coming into the *Souk* through that gated community concept.¹ It worked very well for us, because we could actually see where people were coming in and out of the *Souk*, and eventually were able to do Step ECPs, vehicle Check Points, and roll out there.

So if we identified that a vehicle had a possible cache in it and it was transporting it outside of the *Souk*, we could follow that, see where they were coming through and then be able to follow those guys throughout the AO and then be able to execute a Snap ECP or call in some kind of air asset to take that target out. So, before I even began the building of the barrier plan I was going out there and placing those Jerseys along every single intersection leading onto Ice Cream. That gave me additional stand-off away from that building. Because my fear wasn't a vehicle coming from the north or the south, but a vehicle coming from the side, so when I was able to push those barriers out it increased my stand-off so if a vehicle did blow up across the street, you had buildings across the street that were going to help mitigate that blast effect and at the same time prevented that vehicle from getting anywhere close to the actual OP itself.

¹ *Souk* means market place. The Souk was located to the east of 17th Street Police Station.

Another thing that helped was the lay of the land. The open area out back was a soccer field, and it allowed us to develop a class four point where we were able to drop off barrier material in a secured area. At the same time, it allowed us to stage our vehicles back here in a secured point that we didn't have to worry about insurgents interfering with our activities back there. 17th Street basically was the standard for all OP builds in the area. It's like going up to bat for your first major league baseball professional career, you get up and you hit a grand slam at your first bat, that's how 17th Street Security Station was, because we always compared our OPs to that one right there. It took three days and three nights to build and it was by far one of the best structures that we ever built. I actually have some plans I can show you.

Knarr: I'd like to see that. Maybe not right now, but I'd like to see that.

Knarr: Adel, who's your interpreter for, was Colonel Journey's interpreter, I don't know if you knew him, but he had a lot to say about the 17th Street. He said there was a lot of stuff going on there.

Graniero: Yes Sir, and Alpha Company, guy named Captain Sloan, was the Company Commander. That was a company size OP and it provided him a base of operations to be able to go out and interdict in all the surrounding areas. It also provided over-watch for all of Ice Cream, which at the time before we actually built 295 and 17th Street Security Station, Ice Cream was one of those roads that you knew not to go on, because you knew if you went on that road you were either going to get hit with an ambush or you were going get hit with an IED. We're not talking about just a 15 pound type charge we're talking about a [K-kill] on your vehicle type IED, anything like over 50-60 pounds. And back in those days with M-1114's and IED of 15 pounds or more was going to flip that vehicle and cause catastrophic kill on that vehicle, so we knew that if we went down Ice Cream those were the kind of things we were going to experience.

And so once we built 17th Street Security Station we were able to, basically just like in World War II with the Pacific Island Campaigns you know we were able to cut off the enemy from being able to use that area to their advantage and we now had over-watch on every single piece of ground from Ice Cream all the way back to Hurricane Point. And then, probably the next one in December would be the Qatana Security Station.

It went from OP Checkpoint 295, and then from there we went to OP Utley which was right here [southeast of Hawk]. And then from Utley we went to 17th Street Security Station. From 17th Street Security Station we went to OP Firecracker, because one of the

problems we didn't have good visibility or over-watch over in this area right here, so OP Firecracker provided that for us. From OP Firecracker we then moved to Qatana. After Qatana was done we moved to OP Racetrack. And then from OP Racetrack to OP North and then we also did some other projects like we extended out the barrier planned in OP Hurriyah. We did the same thing down here at the Gov Center. We did the same thing for OP VA, OP Virginia. And then we also built a police station off of Michigan right over by OP VA that we did on November 10th, 2006. The reason I remember it the most is because it was the Marine Corps birthday and we were working all night long and we came back and enjoyed ourselves a nice two beers.

Knarr: Well, who worked with you on 17th Street? You said it was CBs and Army and...

Graniero: Yes Sir. With 17th Street Security Station it was a very large project that was well above the capabilities that my platoon had, organic. So the brigade provided Charlie Company, 1st of the 9th Engineers, this guy named Captain Dick the company commander. His company was actually in support of us during that entire build of 17th Street Security Station. So you had Captain Dick, engineer company, you had my engineer platoon which was mostly involved with the barrier emplacement, because I had the heavy equipment to do it, and then you also had the Navy CBs.

The CBs were responsible for the life support function, like the electricity, the water support, the fuel support, all that stuff that you know, life support functions with inside the OP itself. And then they also provide the 40 ton crane, because the 17th Street Security Station was a four story structure and the only way to get some of these bunkers on top of the roof was utilizing the 40 ton crane. And so that's how all three of us worked.

So when we came down to drafting out the plans for the construction, I was responsible for designing out the barrier plan. That's including the portion of the gated community concept where we blocked off all the intersections. We built two avenues of approach into the compound, we placed barriers all along this, along the perimeter of the building itself, and then also I was responsible for the force protection of the internal part of the building. So, like I said I was involved with the barrier emplacement. Captain Dick's Soldiers were involved with the actual force protection of the building, getting the bunkers on top of the roof, getting those sandbagged in. And then the CBs were responsible for going through and wiring for electricity, hooking up all the generators that were going to be required to support that large of a building, also building the latrine

facilities or head facilities for the Marines, all the WIF support functions and then also utilizing the 40 ton crane. So that's how we all kind of worked jointly. It worked out very well. Captain Dick and his soldiers worked very well with my Marines. My Marines worked very well with the CBs.

It was kind of unique because you'd look around and you'd see the old style desert camis [camouflage uniforms] with the coffee stains [camo pattern] with the CBs, then you'd look over to your right and you'd see a bunch of grey uniforms, then you look over and you see a bunch of tan uniforms. And it was awesome to see us all integrated together, all working to ultimately build this OP for the grunts of Alpha Company. When it was all said and done we were able to all come together as an engineer unit, whether they were CBs, Army or Marines come together and build this monstrosity of an OP. It was by far, like I said, one of the best OP builds and everything was kind of based off of this one.

Another unique thing about this OP build was just the magnitude of it. Not only did you have the engineers, my engineers, Captain Dick's engineers, and the CBs working onsite, but you had all the large logistical assets that were pushing materials out to us, and just the logistical effort from the Army, the Marine Corp side of the house, and from the CBs pushing all this material out there to us. It was amazing how it all just kind of came together. Any kind of hiccups were immediately taken care of and we were able to complete our build within three days. Something of that large, I want to say there was over 100,000 sandbags emplaced in that building over three days.

Knarr: Wow!

Can you speak to COP in a box?

Graniero: COP in a box kind of came from this, kind of came from our building of these COPs throughout the city. What they were trying to do is come up with a BOM, or a bill of materials list, of just materials. Whenever we order any kind of class form materials we have to put it in a BOM [bill of materials], and that BOM gets sent up through our supply and logistics.

Knarr: When you said BOM, I thought you said "bomb."

Graniero: That's another unique thing about the Army and the Marine Corps is our terminology. When I graduated from the Engineer Captain's Career course which is an Army PME [professional military education] school for their captains, so it was very

difficult as a Marine officer going to an Army school and learning their lingo, because I would say “head” [bathroom, latrine] and they would look at me like, “Head, what are you talking about?” “Oh I’m sorry, the latrine.” So that was one of the unique things because Major Knarr and Captain Dick would say, “I need the BOM” and I’d look at them “like, you mean the BOM?” And they’re like, “Oh yeah, that’s it.” But once we got the jargon taken care of and we figured out each other and how we spoke it made things a lot easier.

But, COP in the box, what they were trying to do was create a bill of material, like a standardized plan that no matter where they were in Iraq they could occupy a building, have this BOM, or this bill of material, go out there and be able to build themselves a COP overnight. And that was the whole concept behind the COP in the box. And it’s a good concept. The only issue that I saw with that was that every single building, no matter where you, I mean every single building, even the building right next door to you was going to be different in their construction standard. That was one thing I noticed about Ramadi was that you could be sitting here at Qatana at the Sanitation building and the building to the left of you is going to have a different building standard, or a different building code. And so you really couldn’t design one structure compared to the next one like; for instance your bunkers. You know there was no standard way to build your bunkers because if you built it and your firing port was here it might get obscured by the wall that was over here, but in another building it fit perfectly. So that was some of the down sides of the COP in a box.

Knarr: Yeah. But that’s neat. What I’d like you to do now is walk through all this stuff on Qatana. I’d like you to just sit back and walk through that again, but what I will do is I’ll take some of these pictures and I will embed them right beside when you’re talking so people understand exactly what you’re describing. Does that make sense?

Graniero: Yes Sir.

Knarr: Ok. So, again, start at the beginning on Qatana. Why Qatana?

Graniero: Yes Sir. Qatana, the reason we were going to build an OP there is we were trying to do the leap frog just like they did in the Pacific. And what we were trying to do is we were trying to encircle the *Souk* [the *Souk* was south of Qatana] and basically provide over-watch over that entire area so that the enemy couldn’t move people or material in and out of the *Souk*, such as weapons, or IED making materials or whatnot. And when you look at the progression of how we were working throughout the area of operations is

we went from 17th Street Security Station to Firecracker intersection then over to the next main intersection which was Qatana. So initially we said, "Hey this is our next island that we're going to take over." We looked at all the buildings in that surrounding area and one of the things that we did prior to going out there and executing is actually design three different types of buildings to actually have a primary, a secondary and a tertiary plan of attack for building Qatana. The reason was because all of our human intelligence reporting was saying that the buildings were all rigged to blow with explosives. Since we were not able to actually get in there and conduct a reconnaissance of the building we couldn't verify that information.

So what I had to do as an engineer is I had to go and I had to look at three of those buildings in that area, look at the, look how tall the buildings were, how much visibility did they had down these certain avenues of approach like the Racetrack or Give Me Street which ran from south to north [just north of Qatana]. So, once I looked at all those buildings, we identified the Sanitation building as the primary building that we were going to occupy as Qatana. The alternate, or second candidate site was the building across the street from the Sanitation building and then further down the road was our tertiary. So when we were looking at those buildings, like I said the Sanitation building provided the most observation down all the avenues of approach that we were looking to cover. It was also probably the tallest of the three buildings in that area also. And in an urban environment it's always good to be in a building that's taller than the other buildings around you, because nobody likes to be shot down on by the enemy. So, the first step was identifying which buildings we could use. So we identified that the Sanitation building was going to be the building that we were going to use to build the OP at.

Assuming we were going to use the Sanitation building the next thing I looked at was to emplace my barriers to give me the stand-off that's required, to make sure I am not impeding all of the mobility in the area, because that was one of the issues that we were running in especially in Ramadi. I don't know if you got, from the picture that I saw that you had the T-walls probably right in the center of the road and that reduces your mobility throughout the area of operations, and I had to make sure that my barrier plan wasn't going to impede 1/6's mobility in Ramadi.

So, looking at a map, getting the scale distance from looking at an object on the map, I was able to draw my barrier estimation, draw my T-walls, my Texas Barriers to give me

the good force protection, not only to give me blast mitigation walls, but also to prevent from any kind of observation into the actual compound itself.

Third thing I had to do was look at the structure itself and looking at where on the roof I would actually place my OPs, my Crow's Nest, to give me the observation on those avenues of approach that we needed to keep eyes on those roads. So, that was the next thing in my planning process.

And the last thing was going out and actually coming up with the bill of materials, the BOM, looking at what was going to be required to make this building survivable against any type of attack, whether it be a VBIED, mortar attack or small arms fire. And that's where Qatana was a little bit different than 17th Street Security Station and a lot of the other OPs I built because the brigade had new barriers that were made of poor quality concrete. They didn't allow enough time to cure, so you'd barely touch it with the fork lift or you bump it with a vehicle and it was going to deteriorate and break off. So that was one of the issues that we ran into. Another issue that we ran into was that we were limited on the number of Jersey barriers, because the brigade was short and they didn't have enough to support us.

Knarr: Where were they making these?

Graniero: I want to say they were making them out towards Al Qaim. They were making them out west and then they were shipping them into Ramadi. And like I said, another issue that ran into with the barriers was that, you know beforehand we had been operating with the Texas barriers, but now there was a new design of the Texas barriers that we were receiving that was totally different than what we originally had planned for. Because of that we had to change the configurations of how we loaded the trucks and that decreased the amount of barriers we were actually able to transport out there. Additionally, these barriers were also narrower and I needed more barriers to make up for the loss. I want to say they were about two feet difference between the old Texas and the new Texas barrier. So my original plan had asked for so many Texas barriers based off the numbers of the seven foot length, now it's five foot in length, so now I have to figure out the difference and add on that many more barriers. Unfortunately, we didn't realize this until probably a couple days beforehand when we were loading in preparation for the build. So, that was one of the big issues that we ran into.

Another issue is that we couldn't get the vehicles that we needed to support us. We were only allocated so many vehicles. We didn't get the 40 ton crane in support of us,

because it wasn't available at the time, so we had to rely heavily on M-88s to emplace out key walls. That is a slower process and caused some other problems.

Another issue is that I had two armored trams in support of my operations. One was for offloading the barrier material and the other one was for emplacing the barriers. About ten minutes into the operation the rear axle on my tram, on the fork lift, snapped in half and so now I have a disabled tram that's sitting in the middle of my work area and I only have one tram to operate. So we had to quickly [hobble] off that, pull one of the M-88s off of putting in a T-wall section and use him to help emplace those barriers, which was a lot slower and not the preferred method to be doing it.

A number of issues prevented us from starting on time. Alpha Company and Charlie companies were clearing the areas and creating over watch positions to support the operations and that took longer than expected. Additionally, Racetrack was, they called it IED crust, they had identified well over 20 to 30 IED, possible IEDs along that route. So, route clearance which is an Army unit that was going through there. It took them maybe six to seven hours actually to clear from Firecracker intersection to the actual Sanitation building itself. So, we were waiting at Camp Ramadi for seven hours; that was seven hours I couldn't be onsite beginning my construction under the cover of darkness.

Additionally, it was reported that all of these building could be possibly rigged to explode. So we had to send an EOD, bomb detections dogs, they weren't IED detection dogs, they were basically dogs sniffers, off leash to find caches, we had to use those and at the same time we sent Marines in there to inspect the building before we actually occupied that building. So that took time and by the time we actually occupied and we began construction we were already well into the early parts of the morning and we were definitely exposed to daylight.

At about 0600 on, I believe it was the 19th is when they actually occupied the Sanitation building. And this is when the sun's about rising. You recall our discussion of the gated community concept? Well, as the route clearance was pushing forward and the grunts were clearing to the south and to the north, my engineers were placing barriers along every major intersection, again because our biggest fear was that they were going to run a VBIED up into our work area from the side so blocked off those intersections. By the time we got to the Sanitation building it was about 0600 when the engineers occupied that building.

Barrier material started arriving onsite probably about 0700, and that's when we started building that outer perimeter with the Texas barriers. About 0900, we had one portion of the perimeter built with the Texas barriers and we had already received one load of sandbags and the Marines were basically, fortifying up the windows – blocking them off so that no one could look inside those windows and whatnot and to provide additional force protection. It was probably about 0900 that the D-7 operator was shot in the leg and we actually had a D-7 that was still running in the middle of the road as we're trying CASEVAC this Soldier out. At about 0900 we CASEVAC'd that soldier and about 09:30 the second sandbag truck arrived.

I walked into the building to tell the Marines to get up and to start moving sandbags into the building and that is when the IED was triggered on us. We had about ten casualties, mostly guys from Charlie Company, 1/6. We then began the process of moving these guys out of the building, we CASEV'd them back. It took about 30 minutes for all that to clear up. As soon as that happened we then took two direct hits from either a 83 millimeter mortar or a 120 millimeter mortar, what we got I really don't know. We took two direct hits, we received another additional ten casualties that we had to CASEVAC out and this is when we realized that this building was no longer going to be used as the OP. Once that IED attack happened and the mortars hit, operations outside kind of ceased because we didn't know what was going in. It was really chaotic, nobody knew what was going on inside the building because we were just standing there and the next thing you know the building blows up underneath our feet. As you can imagine, we realized we could no longer stay there and began preparation to actually move out of the Sanitation building and make our way to the next building.

The next building was the Oil Ministry building, and that was the building that we actually occupied for about ten hours or so. And then we identified there was some more IEDs that were planted inside the walls that the Marines accidentally found when they were throwing MREs into the building. [1:13:06 S1]

Knarr: Can you describe how they embedded the explosive device in the floor.

Graniero: Yes Sir. When you walked into the Sanitation building, the picture you showed me earlier of the, of your group walking to the front entrance, that was, that foyer that opened up as soon as you walked in, underneath that there was a tile floor like a, I don't want to say a marble tile, but it was some kind of, it wasn't like a fake tile like you would see in kitchens. I don't know what type of material it was. But, you had that laid

down. It looked very clean. The area actually looked like it'd just been painted. And we really didn't see anything that triggered us that there was an IED underneath the floor. Like I said we were in that building for almost three hours before they actually popped it on us.

Later, as we walked around looking at the building we were able to see what they did. Days prior they had actually gone into that building, broke up the concrete floor, removed the tile and planted an IED of some sort underneath the floor, resealed it with concrete and dirt, retiled it, painted over, cleaned it and made it look like there was nothing even there. What they also did was they ran command wire out of the building, followed along the telephone lines to another building where they must have had a guy sitting there ready to set off the IED. And they probably had a spotter across the street because you could, from where the building was, somebody must have been observing us from across the street to see that we were standing up and getting ready to start moving the sandbags into the building. The first time we went into the building they let us get away with it. The second time they popped it on us, but luckily we didn't have that many casualties, no KIA, mostly just WIA, mostly just a little bit of minor fragmentation here and there. [1:16:15 S1]

Knarr: That's incredible!

Graniero: Yes, Sir. All I remember from my standpoint is I was just walking into the entrance of the door, I was just about to tell the Marines to get up and start moving sandbags and that's when, I just remember my ears ringing, getting thrown down to the ground and just like seeing nothing but gray smoke. All I remember is doing a real quick pat down on my body to make sure that I wasn't hurt, I stood up and all I could think about when I walked in that building was seeing casualties. That's all I could think about was just seeing my Marines dead. As I walked in I fell into this whole that was about a crater size about three feet deep. So, that's when we started going, "Oh my God what the heck's going on here?!"

That's when operations outside kind of ceased because we didn't know what to do. We were waiting for guidance from higher to say, do we continue on building this, because the fear was that, that there were more IEDs in the building and I had no way of checking. I did have some metal detectors with me, we broke those out, but it was a concrete structure and underneath the floor and in the walls with the concrete you have reinforced rebar which was throwing my metal detectors off. And so we really couldn't

tell if there was any other type of explosives buried in the walls or in the floors, so that's when we began pulling out of that building and occupying the next one.

Knarr: Can you walk again through how the rounds in the wall were discovered?

Graniero: Yes, Sir. When we left the Sanitation building it was probably about 12:00, 12:00-13:00 timeframe. We occupied the next building and we established security positions in the building. And a lot of us had been up for over 24 hours at this time period, so we developed a shift. We were going to wait until night to begin the actual construction of the OP, because we had now decided this building was now going to be the OP. So, we all kind of racked up for a couple hours and then probably around 18:00 they brought in a resupply convoy with MREs and whatnot. [1:18:25 S1]

As the Marines were moving the MREs in, they were just tossing them off to the side and one of the Marines had happened to grab a case of MREs threw it, hit the side of the wall, kind of exposed the wood panel open a little bit, another Marine sees wires running up and down this wall and goes, "What the heck is that?" we then grab flash lights, look behind the wall and as we peel it back we see the 155 rounds double stacked on top of each other nose to nose and with the blasting caps inside the fuse wall. And that's when we knew that this building was also rigged. We started tracing the wires and we found more explosives in the wall, that's when we knew that we had to get out of this building. We then pulled out of that building and continued to move back towards Firecracker intersection and occupied more buildings for the remainder of the night. [1:19:14 S1 See Figure 4]

The following morning I pulled out with my platoon, went back to Camp Ramadi, linked up with 16th Engineers and began the planning for the new Qatana Security Station that was right across the street from the Sanitation building. So, Major Knarr and his guys from Bravo Company, 16th Engineers were not involved in the actual initial construction of the Qatana Security Station. It was after we had been blown up in that building, found the IEDs in the

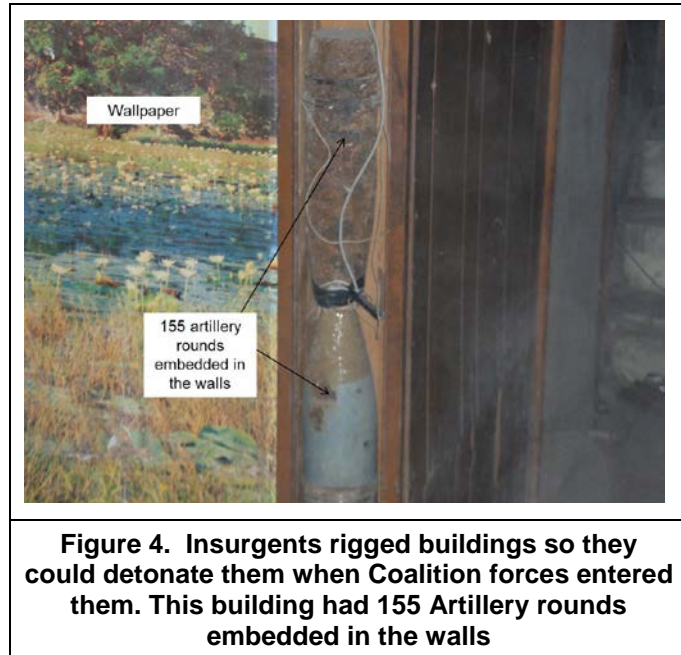

other building, before they were actually brought in and helped in the planning process and the construction of the Qatana Security Station. [1:19:51 S1]

Knarr: That incredible!

So now this was your third building. First was the Sanitation building, the second was the Oil Ministry, and the third candidate was the where you actually set up the Qatana Police Station that you then built. Is that right?

Graniero: Yes, Sir. [1:25:50]

And that day, when I went back to Camp Ramadi I immediately went over to 16th Engineers, I linked up with Lieutenant Colonel Webster, Major Knarr and I began the planning process on the new Qatana Security Station. One of the first things that we decided on when we were going to build Qatana is we had to get back on site and do a really good reconnaissance of that building and see what buildings we could occupy because of the threat that more buildings were rigged to blow.

So, we had to get back out there, recon these buildings, see if these buildings were even usable for us to build an OP before we could actually go and continue on with the planning process. So that was the initial phase of the operation. Major Knarr, a platoon from his company and my platoon, we went out there, reconned out four of the building structures, decided that three of the four needed to be demolished because they were already damaged from previous attacks. That's when we decided we had to blow them

up and then level the ground out. We would then build the live-in containers and the company headquarters in the fourth building.

The following night we went back out, I blew up the old Iraqi IP station that was right there at the corner, the one that had the JDAM [Joint Direct Attack Munitions] strike in the back, I blew that building up. There was a bunch of storage sheds in the back of that building that I also blew down. That's where we found the weapons cache that we also incorporated into the demolition of that building, we stacked them and blew them. And then the Army engineers blew the triangle shaped building that's right there on the corner and then leveled down. After we got done with the demolition piece that is when the Army brought in their D-9's and D-7's and began leveling the ground. And this is when the D-9, during the leveling of the ground, clipped a main water main in the area and began to flood the area out. By the time the water had been turned off you had what we called Lake Qatana that had developed in the back of this area and it was in some areas over three feet deep, and it was a mixture of not only water, but human waste and a bunch of other sewage.

Knarr: Wow. Can you walk through the development of the stations?

Graniero: Yes, Sir. Like I said during the initial planning process we first did a recon, we looked at the buildings, what was salvageable, what could we use as part of the plan and when you look at the map of the actual plan itself, the building that we utilized for the live in container, we identified that that building was salvageable. There was no damage to that building and that would be perfect for housing Marines and also the company headquarters. The other building to the left of that which was the old Iraqi Police Station had a lot of structural damage to that, so we identified that building needed to be destroyed. That building my Marines destroyed. The next was a triangular shaped building that had a lot of structural damage to that, Major Knarr's platoon went in there and destroyed that one. And then the other, there was another building that we eventually used, utilized later on in the project, that we used to house an OP, like a Crow's Nest on top of that to provide over-watch. So, those were the structures. That was the initial part. [1:24:07]

Demolition, then we came in with the D-7 and the D-9, tried to level the ground, we clipped the water main and that's when things really became interesting; [we will get back to that].

I was responsible for the barrier emplacement, so I developed a barrier plan around the backside and the front side along the Racetrack for the Qatana Security Station. In the front along the Racetrack the barrier plan was very easy, we had the 40 ton crane in support of us and were around the rounds we had a smooth surface to place these barriers on, so the process went very well. [1:24:48 S1]

In the rear of the compound and on the flanks this is where it became very difficult because of the soil and also because of the water. Soil and water – a lot of mud in that area we weren't able to get the forty ton crane back in that area to emplace the T-Walls in the rear of the compound so we actually had to utilize M88's to emplace these barriers. This was a very slow and drawn out process. And that is why if you would look at some of the old pictures of the Qatana security station, the barriers in the back are not as straight as can be and are not as level and that is because the lay of the land just didn't allow it. We couldn't get any kind of heavy equipment back there to improve the surface. So those were some of the problems.

The way that Major Knarr and I worked this out was my platoon was working 12 hours, either from 12 o'clock in the afternoon to 12 o'clock at night or I was working 12 o'clock at night to 12 o'clock in the morning and we were doing this day-in and day-out for almost a month and a half before that building was actually completed.

Now with the barriers, we originally did the front side of the barriers first and then we began the backside and the flanks. That took the longest period of time because the M88's are not as maneuverable, especially when they are carrying these barriers. So we had to use our trams our fork lifts to lift the barrier 13 foot tall T-Walls and place them in front of the M88. Then have the M88 lift the barrier up, have a soldier or a marine get out there unhook the chains and then continue doing that process. That took us maybe a week and a half to finally get all those barriers out there in the back. Of all the casualties that we took during that time period, three of the casualties were M88 operators. They were probably the most exposed of all of us during that time period because they were either on the ground or they were on the barriers unhooking the chains.

Knarr: Now while you are doing all this what were the other people doing?

Graniero: The guys that weren't working the barrier placement were working the inside parts of the building. We had identified, three buildings, basically storage containers, like a warehouse kind of like storage unit areas like a garage unit. Well, all those garage units were actually filled to the brim with materials, some had tools, some had old mopeds,

like Iraqi motorcycles that we found in there, just a bunch of junk, people's household belongings were in these buildings. So we had to get dump trucks into this area and remove all this material before we could actually start making these into living containers and a company headquarters. It took about three days to finally clear all that material out of there.

Once we got all that cleared out CBs then constructed, they framed out a wall to put in place of the metal door that was in front of the garage. We had basically framed it out so you would have an AC unit and a closable door. Once they had those framed out we then used a rivet gun to emplace them to the concrete and secure them in the wall. Once that was done the Seabees began the process of doing the interior wiring, wiring it for electricity, wiring it for outlets, for the lights, and also for the AC units. During this time period the CBs also brought in their generators to run the OP and set up the breaker boxes and everything established for that. While they were doing that the marines were also on top of the roof emplacing the sand bags and building the overhead protection with the standup distance between the pre deck and the sandbags. In conjunction with that they were also building the crows nests on the corners on the buildings and fortifying those positions. They were also making hot and cold positions for small rockets utilizing sandbags and HESCO, two foot HESCO to build walls so they were able to move along the roof without being seen by the enemy.

Once the crows nest were complete and the interior part was all done to include the all the walls, then we put in the snipers screen around all the barriers. What we did, and this is something that Major Knarr and his guys developed, is they took six foot tall fence poles and they strapped them to all the T-Walls along all the entire perimeter of the camp or the OP. They then began draping them with this black mesh material that you would see on this chain-link fencing basically to shield them. The problem we had with the OP itself is because we built it from the ground level up and we were only working on one story structures, all the buildings in the area looked down on to our OP. So the thought process was with the 13 foot tall T-Walls, the 6 foot screen that they had emplaced around the perimeter would give you some protection or I guess some protection from observation from the enemy.

Bill: Concealment

Graniero: Yes sir, concealment. And that's what we were doing and that took about a good week to complete that project. And then finally, one of the biggest issues was with the

water – we could not get the water out. We were walking or wading and moving vehicles around in three foot of sewage water and mud. So we tried to suck the water out with the water pump that worked a little bit. Then what we dumped load after truck load after truck load of gravel and dirt and other fill materials into that area to basically try to absorb or push that water out of the area and onto the roads and then build the foundation.

This is to kind of give you an understanding of how long it took. It took almost a month and a half from start to finish for us to finally be done. And even to this day, till when 3/7 actually went in there and took down that OP they were still improving on it six months after the fact.

Bill: Well, now 3/7 took it down and is that when they then built Qatana across the street were you originally in the sanitation building where you originally planned on doing it?.

Graniero: Yes sir. So it kind of makes one big circle, the original building that we designed blew up on us, we then moved across the street, we built there we clear that then we go back, actually the Iraqi police went into that building and cleaned it out and cleared it.

S1 is 1:36:08 length

16 January 2013

Subject: Interview with Colonel John Charlton, former Commander, 1st Brigade Combat Team, 3rd Infantry Division, in Ramadi

Colonel John Charlton, commanded the 1st Brigade Combat Team (1st BCT), 3rd Infantry Division (3ID), in Ramadi from February 2007 until March 2008.

COL Charlton was interviewed at IDA on 20 October 2010 by Dr. William (Bill) Knarr, Lieutenant Colonel David Graves, USMC and Ms. Mary Hawkins, all of IDA. The following is his account of the Awakening.

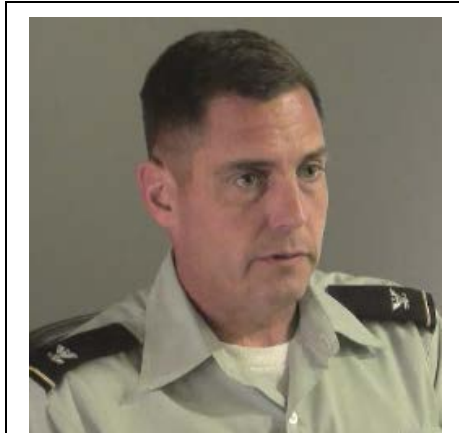

COL Charlton, former Commander, 1st BCT, 3ID

Dr. Bill Knarr: Colonel Charlton, please provide some of your background and then we'll talk about your pre-deployment.

Colonel John Charlton: Sure. I'm a career infantryman. I have worked in all types of infantry, whether it's Rangers, mechanized, or Airborne, and I've had three tours in Iraq. All of them were with the 3rd Infantry Division. I was the Battalion Task Force Commander for the initial invasion in 2003. I came back in 2005 as the G3 for the 3rd Infantry Division working out of Baghdad. Then my last deployment was in 2007/2008 as a Brigade Combat Team Commander in central Al Anbar Province, Iraq.

Knarr: And when did you take command?

Charlton: I took command in June of 2006 in Fort Stewart, and we had about a six month period of preparation before we went into Iraq. One of the things that was unique about the brigade at the time was this was the third time the brigade had gone to Iraq, so it was a fairly big deal. We had gotten to that point now where units were starting to go back repeatedly, and we were the first one to go for the third time. So there was a lot of focus on what impact that was having on families and soldiers and so forth.

Knarr: I bet. When did you know you were going to go into Ramadi?

Charlton: Not right away. In fact, we did not know we were going to Iraq until probably late summer. We were in a prepare-to-deploy status, so we were working very hard on readiness in terms of getting Soldiers ready to deploy and training and all of that. But we

did not know for sure that we were actually going to deploy to Iraq until, I think, the late summer. And then we got the word, "Yes, you're deploying to Iraq, but we don't know exactly where you're deploying. So, we're going to prepare you in broad terms." And so when we did our mission rehearsal exercise in September, we actually went into that not even knowing exactly where we were going to go. And because we were on such a compressed timeline, instead of going to the National Training Center or the Joint Readiness Training Center as all units typically do, they brought the National Training Center to us. They literally brought all of the role players, the opposing forces, the Iraqi role players, all of the controllers, vehicles, and the gear. They did a lot of preparation there at Fort Stewart in terms of building up little villages and things like that to add as much realism as they could to the exercise and make it as good as a rotation to Fort Irwin. But they did this because it was the only way they could meet the deployment timelines and still allow us to receive the necessary training that we needed before we deployed and give us some time with some family and that sort of thing. We went into that not even understanding exactly where we were going to go. I think it was about half way through when we actually got the word that we had been pegged to go to Ramadi. So we finished up the rotation and then we had a little break and recovered our equipment. Then from there the task in November was to go over and actually do reconnaissance of the situation in Ramadi and link up with the unit that was there and do specific preparation for deployment to Ramadi and central Anbar.

Knarr: As you look back on your training on the MRX [Mission Rehearsal Exercise], what do you think are the things that you would rather have focused on? Do you think you got what you needed? [4:22]

Charlton: I think we got what we needed and particularly in the amount of time that we had. Like I said, the Army as an institution and the division went to great lengths to ensure that we didn't sacrifice quality even though we were on a compressed timeline. There was no piece of training that we didn't get to because of the time limitations. Obviously, there are always things you would want to do more of. You can never do enough cultural and language training for this type of deployment, but we did a good amount of that and I felt that when we went over there we were pretty well prepared.

Another thing that helps, going back to the pre-deployment, is that the majority of the brigade was not new to Iraq. They had been to Iraq. Probably about 75% had been there once before and probably about half of the brigade had been there twice. And it was only for the newly arriving soldiers and officers that this was their first time. So they got the

benefit of the training, but they also got the benefit of having people on their left and right that have a great deal of experience already in Iraq and have learned a lot of lessons in a combat environment. Add that to the training and it really, really helps get you prepared.

Knarr: How many of your units did you take back with you, your battalions?

Charlton: We took them all to Iraq. We deployed as an entire Brigade Combat Team. What didn't happen was that the rest of the division didn't go with us. They came later.

Knarr: What about service support and things like that?

Charlton: Well, I owned all of it. See that was the beauty of the modular brigade. We had just converted over to a modular brigade, so I had my own support battalion. I had my own artillery battalion. I had my own communications. That was the whole purpose behind modularity was to allow us to be more expeditionary. And it worked. I mean we had the ability to build that team during the pre-deployment phase, but they were all organic to me, so it worked pretty well.

Knarr: That's great.

Charlton: We kind of tested that theory, and I'm a big fan of that whole modular concept based on that experience.

Knarr: That's great. So then you went in for your PDSS [Pre-Deployment Site Survey] in, did you say in November/December?

Charlton: Yes, it was right before Thanksgiving. I think we went back shortly before Thanksgiving. You get about a week, ten days on the ground. You do some school house type training there in Taji. It's kind of the COIN [counterinsurgency] Academy that they have where they go over some of the fundamentals of COIN. There was some in theatre kind of training with leaders to get you prepared. And then you go out into your area and link up with the unit that's already there. And that's, of course, extremely valuable, because they take you on the ground out to everywhere you need to go and meet people that you're going to be working with both Iraqi and US. So, that was a real eye opener for us. This was at a time where Anbar was at its worst. It's arguably one of the most violent places in Iraq, which means it's probably one of the most violent places in the world—pretty tough going. So that got our attention real quickly. The guys that were with me, we'd been in Baghdad and we'd seen a lot of action in Iraq, but never-the-less, it got our attention that this was a pretty violent place.

Knarr: Task organization. Ready First was a legacy brigade and you had a modular. Did you have at least one for one as far as battalions? Did you have to change any of the organizational areas, operational of areas for the battalions?

Charlton: Yeah, we did actually. You know it's not an even match up. They had three maneuver battalions, armor and infantry. They had a full up engineer battalion. And so at the end of the day when you did a troop to troop comparison with, my organization, there was about a 400 troop difference with us on the short side. So there was a pretty big difference in the number of forces. And we did have to reconfigure the lay down. But over all we were able to figure all that out during the pre-deployment site survey. And of course we raised it to the attention of the Marine Headquarters there in Fallujah that there was going to be this difference and that we were going to try to mitigate that, but it wasn't a complete one for one. It was helped somewhat or I suppose helped a great deal by the fact that 1st Brigade, 1st Infantry Division, most of the brigade was deploying, but there were a couple elements, three battalions that had been working there that were going to remain and then come underneath my organization. It was 1st Battalion, 77 Armor [1-77 Armor] out of Germany, 1st Battalion, 6th Marine Regiment [1/6 Marines] out of Camp Lejune, and the 1-9 Infantry out of Fort Carson. So that worked well, because they were able to, more or less, keep their same areas. They had been on the ground so my battalions coming in new were able to fold into an organization that still had many parts in the area and that helped with the transition. [10:06]

Knarr: When you started, though, you started off with some pretty big operations right from the start. Can you talk about those?

Charlton: Yeah, we did. I had talked to Sean MacFarland about this during the survey. We had talked about the progression of relationships with the tribes, and the efforts they had made in gaining a foot hold in the city. There had been many attempts to try and gain control of Ramadi and all of Anbar for that matter. Ramadi was just a microcosm of the larger problem in Anbar, that being Al Qaeda had a tremendous grip on this province. And so Sean and his brigade had been working and fighting very hard to get a hold into Ramadi. And working now with the tribes they were starting to build some popular support, which is essential if you're going to do a counterinsurgency campaign. So we could see, it was almost like they were doing a penetration attack, and they gained that foothold. And we had talked about, "So what's the next step? What do we have to do?" And essentially, as we talked about it, we had to have some sort of exploitation. What I did not want to do was lose momentum with what he and his great team had started. That

would be the worst thing that could happen. And so my intent going into this operation was to maintain that momentum and the way I wanted to do that with the forces I had was to essentially do one massive operation to actually clear Ramadi. He had several combat outposts in the city, but there were portions where his control was contested by Al Qaeda, pretty heavily in some cases [See Figure 1. Insurgency]. There was no way that we were going to be able to sustain 12 months or 15 months of this kind of heavy, urban fighting. Over time that would have been a battle of attrition. It would have just depleted us and would have not gotten us where we wanted to be.

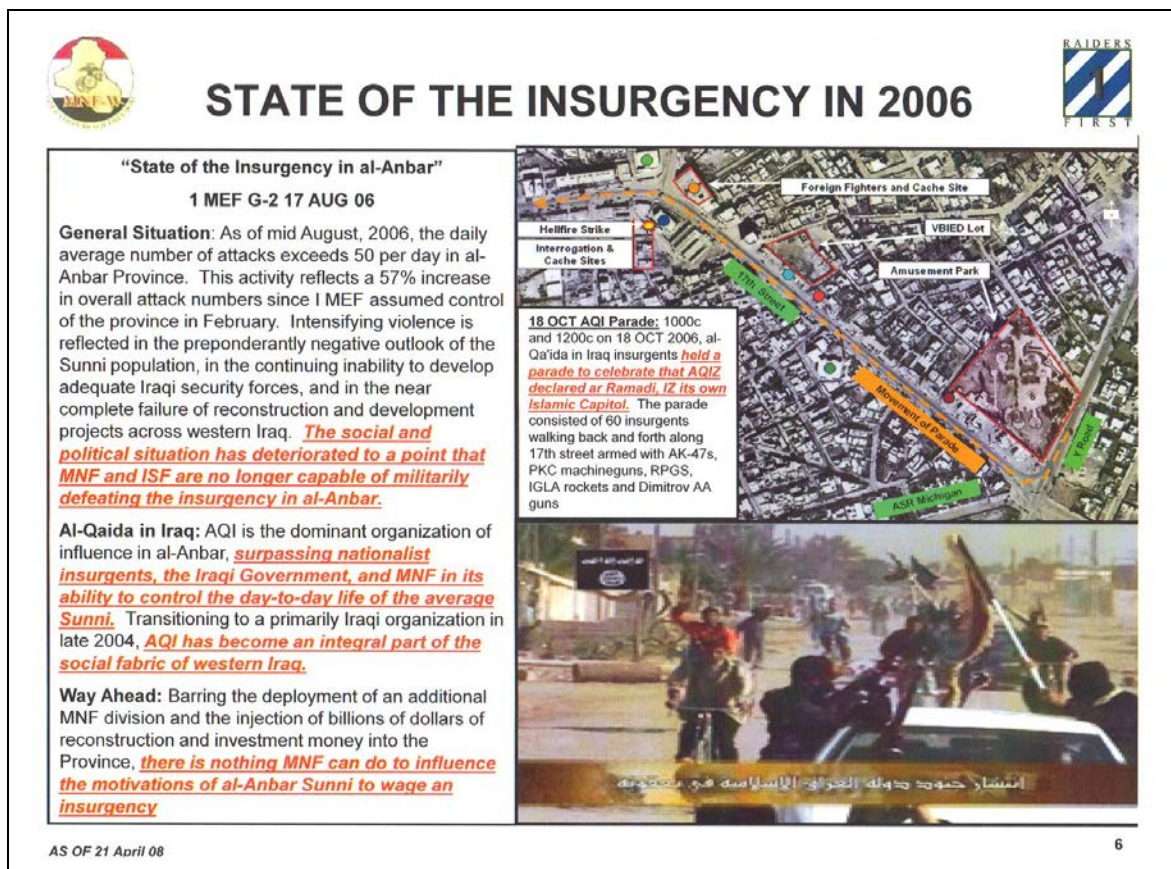

Figure 1. Insurgency in 2006 (Photo Courtesy of COL Charlton)

So, we decided from the outset that we were going to go in right from the beginning. We did not want the enemy to have the perception that there was a lag or a dip because of this transition. So, yeah, we hit the ground running. We did a six week campaign broken up into three major operations. We took the city and broke it into three sections, based principally on the level of enemy presence and contact and attacks that were occurring in certain areas. So we looked at Ramadi and said, "Well what is the center of gravity?"

We determined it to be the southeast portion of the city closest to where 1st Battalion, 9th Infantry (1-9 Infantry) was. It was called the Mula'ab Sector, because Mula'ab is the Arabic term for stadium. There's a big stadium there. This part of the town was really the worst of the worst. There was minimal presence in there. It was pretty much guaranteed that you were going to make contact if you go anywhere near it. We had pretty good intelligence that Al Qaeda was doing everything from, obviously, establishing a heavy presence, but they were building IEDs [Improvised Explosive Devices] and VBIEDs [Vehicle-borne Improvised Explosive Devices] actually in this part of town. That type of thing was going on. [15:00]

So that was the first major operation. It was called Operation MURFREESBORO and it ran from about the middle of February to the first week of March [See Figure 2. Clearing Operations]. The idea was to clear that southeastern part of the city. Now, going back to the work that 1st Brigade Combat Team, 1st Armored Division [1st BCT/1AD] had done, one of the key factors in allowing us to do this plan to clear Ramadi was that we knew we had to have not just token Iraqi participation, but they had to be the face of this clearing campaign. Because when I talked to my leaders about it, we said, "There are a couple of aspects to this clearing operation that we need to think about. There is the physical clearing, which is what people typically focus on." And the idea is to separate the insurgent or the terrorist from the population by going in there, house to house, block by block, and removing them—killing or capturing them.

But there is also the psychological separation that goes with that. And in fact, the psychological separation is really equally as important particularly in the long term. Because if you don't get that psychological separation, you may not be able to hold that area and you may end up having to keep re-clearing it, and re-clearing it, and re-clearing it. So how do you get the psychological separation? Well, step one is to make sure that the Iraqi population sees Iraqis, their security forces, in the lead on this. It is the Iraqi Security Forces freeing their neighborhoods from the terrorists' grip and making the streets safe for their children and so forth.

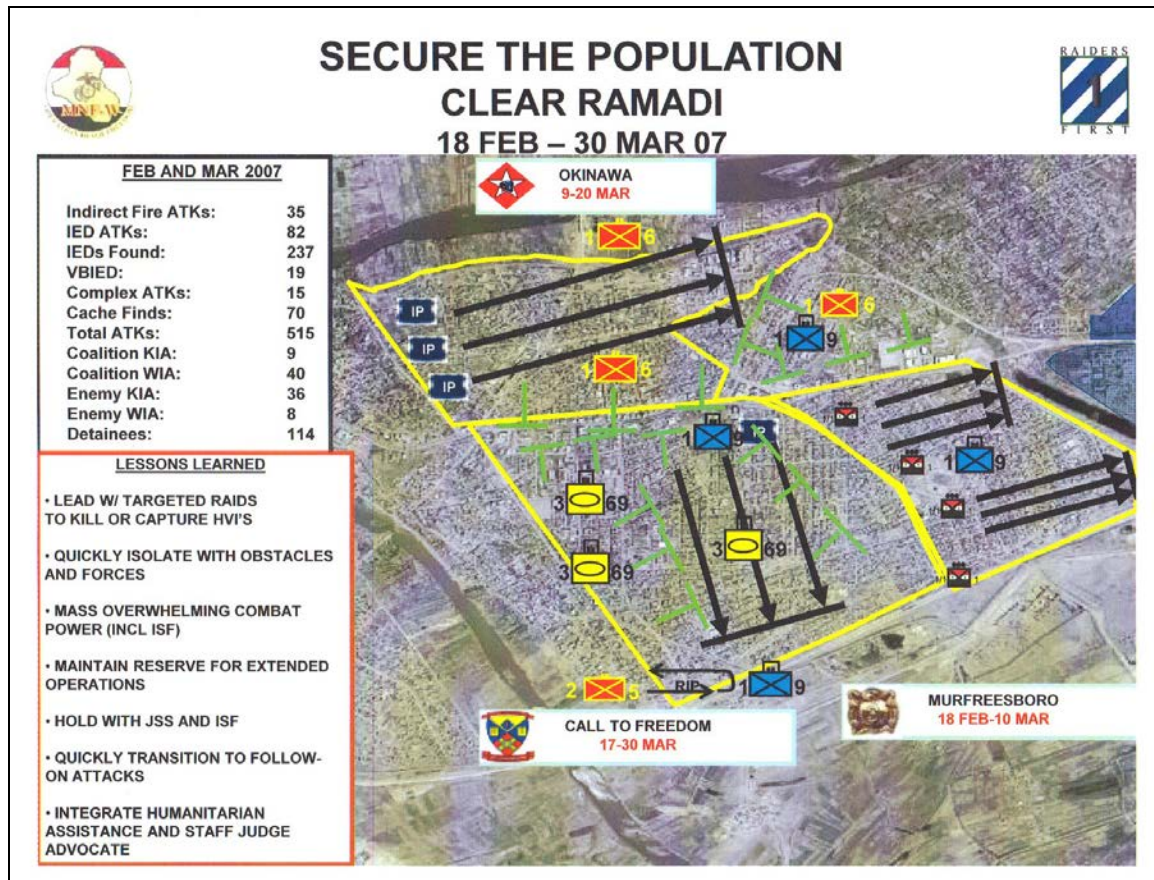

Figure 2. Clearing Operations in Ramadi (Courtesy COL Charlton)

So this goes back to why it's important to gain a relationship with the tribes, because that's how you gain a relationship with a population, through the tribal leaders. And equally as important is that is how you are able then to recruit Iraqis to join the police and to join the Army. And prior to 2006 that had been a pretty tall order in Anbar for a variety of reasons. Number one, we didn't have a relationship with the population, with the tribal leaders. And number two, Al Qaeda was very actively targeting the Iraqi Police in particular, so you're asking a lot for a young Iraqi to sign up and put a blue shirt on knowing that he's instantly targeted by Al Qaeda. So, we do that work with the tribes. That helps with recruiting. It helps us with popular support, and therefore when we go and do the clearing operation, it helps us with that psychological separation. Because we are the good guys now or at least we were on the good guy's team. And the other guys are the bad guys. And so we're going to go in there and physically separate them. And then we're going to do things that allow for that psychological separation by making sure that we leave a lasting Iraqi Security Force presence. So, one of the main focuses of

the clearing operation was to actually plant the Iraqi flag in the shape of a combat outpost or what we later called, a joint security station, a police station.

So when we went in to the Mala'ab, one of the first things we did was figure out what is going to be the end state disposition of US/Iraqi Forces in there and how will we build that? And it started with one main police station right in the center and then we had a plan from there to branch out and have some other outposts. So you had this hub and spoke effect with mutually supporting positions. That was kind of the physical end state we were looking for. We'd go in. We'd clear. The Iraqis were in the lead. They were the ones actually going into the buildings. We had attack helicopters up above. We had UAVs [Unmanned Aerial Vehicles]. I had fighter aircraft. I had communications support. I had medical support. We had everything that was needed to help the Iraqis be successful, and it worked very well. Al Qaeda, I think, was very, very surprised by the level of aggressiveness and the sheer volume of forces that were involved.

Before we did the clearing operation, in order to make the clearing operation successful, you have to do a couple of things. One is you have to isolate the area. This is where massing combat forces come in. All of the other battalions basically surrounded this area. And we actually went in during the middle of the night and dropped concrete barriers, literally, and walled this whole area to a large degree. Then we knew that the Al Qaeda leadership would be the first elements to try and escape. That's typically what they do. They know that they're a target, and they leave their soldiers behind to fight on their behalf. So we did some targeted raids to try and pick off some of those leaders before they could escape. There were mixed results on that, but we got a few. And then we followed with the big massive clearing operation, both physical and psychological. [20:20]

Going back to the psychological piece: the humanitarian assistance and the damage payments are actually a big part of the actual operation. It's not an afterthought. It's not something you do later on. So we structured it so as when we were clearing, we had the humanitarian assistance following right behind the lead elements of the clearing teams. So as soon as they'd cleared a block and stabilized the situation and made sure all the IEDs and bombs were diffused or taken care of, then we would move some humanitarian assistance in right away, again delivered by the hand of the Iraqis to help build their credibility and legitimacy. And then actually we had lawyers out there, US JAGs [Judge Advocate General] out there handling damage claims and dispersing money right there

on the spot. So again, you're working that psychological separation as part of the operation.

Establishing the police station was another lesson learned. 1st BCT/1AD had done a great job of developing some very good techniques on how to do that very quickly. Essentially we called it a COP [Combat Outpost] in the box. They are prefabricated fighting positions with ballistic glass and really thick steel that could be lifted up by a crane and dropped on top of a building and you have an immediate fighting position. Truck loads of barriers and sandbags come in. A platoon of Seabees follow in right behind them with generators wiring the place up so you have power. And you could stand one of these combat outposts up in about two days max and be ready to fight right out of that thing. Because a lot of times the enemy would try to quickly turn around and throw a car bomb at it or something like that. So that's kind of how it went. We did Operation MURFREESBORO the first week of March. We completely secured this area that had been such a horrendously dangerous part of town.

We next turned our eyes north to the area we figured would be the next most violent area. It was in 1/6 Marine's area. It's called Operation OKINAWA. There's a little historical lineage going on with the naming of these operations and the battalion commanders. I let them go ahead and drive that. So Lieutenant Colonel Journey's battalion was the main effort for OKINAWA. Before the last operation had wrapped, we'd already kicked off the second operation. Because again, we didn't want to give the enemy any opportunity to regroup or reform in some area or regain the initiative. So before we had finished up MURFREESBORO we were already kicking off OKINAWA. Again, same idea, we isolate and then use overwhelming force.

In OKINAWA, we used all the lessons learned from MURFREESBORO and did a few different things. One of the things we did differently was we went through and did the clearing operation just like we had done. We had a little bit more police presence in this operation. And then we went through and cleared it again. Because what we had analyzed and determined was that some of the enemy will simply just try to lay low. Rather than fight, they'll just try to blend in with the crowd and you may not catch them in the first drag net. So you do another one, and it worked. We caught another 15 or 20 on the second round through. The second round through almost turned into a show of force, because there were large numbers of police. There were probably 200-300 police, sirens flashing, and a large amount of police on the street, moving through. So again, you get the big psychological picture that's being portrayed for the population that Al

Qaeda is no longer in charge around here. The Iraqi Security Forces are here, and they're here to stay. So you get that psychological picture being presented to the population. It's very powerful and it helps set you up for that long term support and presence. And so we did the same thing.

We set up more combat outposts, and made them interconnecting and mutually supporting, so that you always had a friendly position no more than about 100 meters away. But this was block by block fighting, just like it was in MURFREESBORO, so very, very intense fighting. We took some casualties, but got the job done and secured that part of the city. Again, we followed it up with humanitarian assistance and help to start some normality to that part of town. We immediately shifted to the last part of the city and this was Operation CALL TO FREEDOM. The southwest part of the city still had pockets in that were pretty heavily occupied by Al Qaeda. There was no way we could leave this untouched, so we shifted there finally. Again, we kicked this off two or three days before we had wrapped up OKINAWA so it was all seamless. There were no gap or pause in effects.

Knarr: That must have been intensive as far as troops and other resources?

Charlton: It was. In fact, that was one of the lessons we learned from MURFREESBORO. Even MURFREESBORO, the first one, we found that you really do need to have uncommitted reserves for this type of prolonged urban fight. I actually had to go to the Marine Headquarters and ask for another company of Marines during MURFREESBORO just because Lieutenant Colonel Chuck Ferry's guys were getting so worn out from literally 24 hour fighting that I had to pull some guys off the line. In order to do that I needed a company of Marines, and I got one, thankfully, from the Marine Headquarters in Fallujah. And that gave me enough to get some breathing room. So what we tried to do in the subsequent operations was try to build that in. So that was a mistake from the outset... the amount of fatigue this would cause. The other thing is that you really, really strain your Explosive Ordnance Teams. What the enemy had done, particularly in MURFREESBORO and that part of town was they actually used IEDs in the defensive pattern. They used them like a defensive minefield. We were going through parts of town, through some of these streets and encountering large number of anti-personnel IEDs, taking casualties. Of course then you'd find these places where they make IEDs and so you have large volumes of explosives that have to be neutralized. You can't just leave it there. It's too dangerous to haul out. You've got to destroy it sometime. So our EOD [Explosive Ordnance Disposal] teams are just continually working, and they're

getting worn out. So that was a lesson learned, too. You need to make sure you've got enough of those specialty teams on hand. You're really only equipped to do a steady state level of operations with those assets, but when you go into the major operations, you need to bring more of that in. [27:36]

Knarr: Same thing with the engineers?

Charlton: Yeah, engineers the same way. They're working constantly, because they're moving these barriers around. They're building these combat outposts one after another. Everybody is working extremely hard. But when we got to CALL OF FREEDOM the problem I had down there was I had one of my armor battalions, 3rd Battalion, 69th Armor (3-69 Armor), which is an armor battalion by name, but it's really a modular combined armor battalion. It is two tank companies and two infantry companies, but really the boots on the ground strength is much less than a Marine battalion. As I looked at the situation in that part of town, we didn't have enough to hold it, not in terms of US combat power. I talked to the Marine Headquarters. Brigadier General Mark Gurganus was the ground element commander. I told him that, the way I saw it, I was going to need more combat power.

At the same time, he had a situation south of Fallujah where he needed to get some maneuver forces, because it was kind of the soft underbelly of Fallujah and the enemy was working that line of movement into and around Fallujah and he didn't have anything to put down there. He didn't want to put a whole Marine battalion, which is what they had programmed to come in there. And I said, "Well, let's do this. Let's do a swap. That will help both of us. If you give me that incoming Marine battalion, I will give you my cavalry squadron, which right now is doing an economy of force mission north of the Euphrates in my area." They had not had a tremendous amount of contact. It was a dangerous area, but not like the city. I said, "I think this will be a good swap." General Gurganus agreed with me. So what ended up happening was I had to take my cavalry squadron, 5-7 Cavalry and then shift them over to Fallujah, to their new area. 2/5 Marines would then come in and they would take the center part of the city, southwest part of the city. The unit that I had there, 3-69 Armor would then shift and cover down where 5-7 Cav was. So you had this three way movement. And, you know, it severely violates the principle simplicity in the attack, but it was the only way that we could see how to do this and then leave us with the kind of structure for which we could hold and sustain our gains.

What General Gurganus saw was that these series of operations were working very well. We actually had an opportunity to retake Ramadi with the Iraqis. And so he said, "Yeah, ok, we'll do this." So what ended up happening was 3-69 moved into the outer perimeter and isolated. At the same time they were displacing 5-7 Cav in the north. 1-9 Infantry, led the way in MURFREESBORO

Knarr: With Ferry.

Charlton: With Lieutenant Colonel Ferry. They'd all rested up now a little bit, because they got a little bit of a breather while OKINAWA was going on. So I put them back in the lead. As they cleared the southwest portion of the city 2/5 Marines came in behind them and essentially did a relief in place. So, 1-9 would move through and clear, and 2/5 would come in behind them and hold. 3-69 was on the outskirts isolating and then also displacing 5-7 Cav in the north. This was a very complicated operation. But to the credit of those great commanders and all the Soldiers and Marines working for me, it went off without a hitch. I mean it was a relief-in-place detaching units, bringing in new units, and doing a major urban operation at the same time, and it worked pretty well. [31:19]

Knarr: That's great.

Charlton: And at the end of that operation, which wrapped up about the end of March, that was it, the city was cleared. The 31st of March, we were walking around the city and it was eerily quiet. You couldn't hear anything. Now, any day prior to that you would have heard bombs dropping, tanks firing, machine guns, and bombs blowing up. But on the 31st of March, 2007 there wasn't a single shot fired in Ramadi in anger, not one. You know that was the first time that city had not had a single attack in the day since probably the war started. So, that was the completion of those three major operations to retake the city.

Knarr: And to clear.

Charlton: And to clear. The same methods were used: putting out an Iraqi Police and military presence, partnering with US Forces, and then start working that psychological separation. One of the problems we had is we had a pretty good supply of police for clearing, because we could surge them and move them around. But we didn't have enough police to hold them. We were spread pretty thin, and we were pretty worried about that. So, we started trying to recruit some local Iraqi men out of the neighborhoods to join the police forces. Of course that is not an instantaneous process. It takes a while. So they started out as provisional police forces. This is the precursor to the Sons of Iraq

program. And as we looked around, we said, "Well we don't have any standing by. We can't recruit them and train them fast enough to get them into these neighborhoods. We're just going to have to go out there and grow our own."

So it started out by going to the tribal leaders or going to the police that we had in the town, in the city, and saying, "Go through these neighborhoods and see if any young men are interested in joining the police now that they've seen their city is cleared, now that they have seen what the Iraqi Police can do. They've got the support of the tribal sheikhs. Let's go out and engage them and see if they'll sign up." And they did, in droves. And I'll tell you, it's risky, because you've got a guy that's essentially untrained, but he's standing on the corner of his neighborhood, and he's holding a rifle. You know he knows everybody going in and out of that neighborhood, and he has a vested interest in keeping the bad guys out. It's a part of his responsibility as a member of a tribe. It's a part of his personal pride as a young man in Anbar to fight for his neighborhood. And it worked. We were able to take groups of these provisional police and put them under a small number of actual Iraqi Police working with US Forces. So you had that three way combination of troops that allowed you to hold these neighborhoods. And that was going pretty well, but you would see these guys out there. We would put orange vests on them to indicate that they were good guys. And this started to flourish all over Ramadi and all the battalion commanders got very active about going out and trying to pull these guys in and set up these provision police forces.

Knarr: Who paid for them? Did you?

Charlton: Well, initially. [34:50] We didn't have any way to pay them other than we would appeal to their pride and their sense of civic responsibility. That goes well for about a week. Then you start looking for other ways to help them. Maybe you give them some additional humanitarian assistance. You give them some cooking oil and some rice. That goes a little ways. Eventually you'll run out of ways to keep them on board, so we were really concerned about that. I recall having that discussion with General Odierno when he was the Corps Commander at the time. He was walking through seeing what we'd done in Ramadi. And he said, "We've got to pay these guys somehow." It's going to take a long time to get these guys on the payroll with the government of Iraq, because they need some training. We're going to have to make the coordination with the MOI [Ministry of Interior]. And because these guys are Sunni, they're going to have problems with that maybe. He said, "Look, we're going to use CERP [Commander Emergency Response Program], because this is an emergency situation here. We're

going to use CERP funds to essentially pay security contracts for these young men to guard their neighborhoods. And then we're going to work with the Minister of Interior to eventually get these guys on a payroll." That was the plan. And it just kind of grew out that way from this grass roots effort to build this police force.

So, we had to put these guys through some training to get them safe with their weapons and to teach them the basics of patrolling and securing detainees. We call it the long hot summer of 2007, because you're taking this from nothing and trying to build it up into a legitimate police force with not a whole lot of resources. We were running around trying to get blue shirts for these guys. We were literally sending teams into Baghdad to try and find equipment for them. We tried to get their police stations looking something like a police station. [Figure 3. Raider Task Organization as of 1 August 2007]

And then the training piece, we were fortunate because 1st BCT/1AD had established a regional training center on a part of Camp Ramadi. It wasn't much, but it was pretty darned good for the situation we had. So we tried to take that to the next step and improve and get some money from the MEF, the Marine Headquarters, to get some contracts so that we could get some contracted life support to feed these guys and turn it into something more, something that looks like a real training center. We worked with some of our State Department police trainers in developing a training plan. We sent that in to the Ministry of Interior and got them to bless that as an interim acceptable training regime. So we just went through this process of continually trying to professionalize and legitimize this force. We did that throughout the summer and fall of 2007. And it started to work. Over time these guys would end up getting added to the roles and received real paychecks from the government of Iraq. And then down the road they'd get plugged into the real formal police training course and they would become full-fledged card carrying Iraqi Police. And that was the whole program. All of it was made possible by thousands of Marines and Soldiers, who were out there living in police stations every day, helping them set up an arms room, helping them run a detention center that's humane and well organized, and safe guarding evidence. You had young JAG officers that were down there working with the Iraqi Police investigators to try and build cases that would eventually go to court. All this stuff was going on everywhere across the brigade area. You had troops that were doing different pieces of this whole problem, but just doing it in amazing ways.

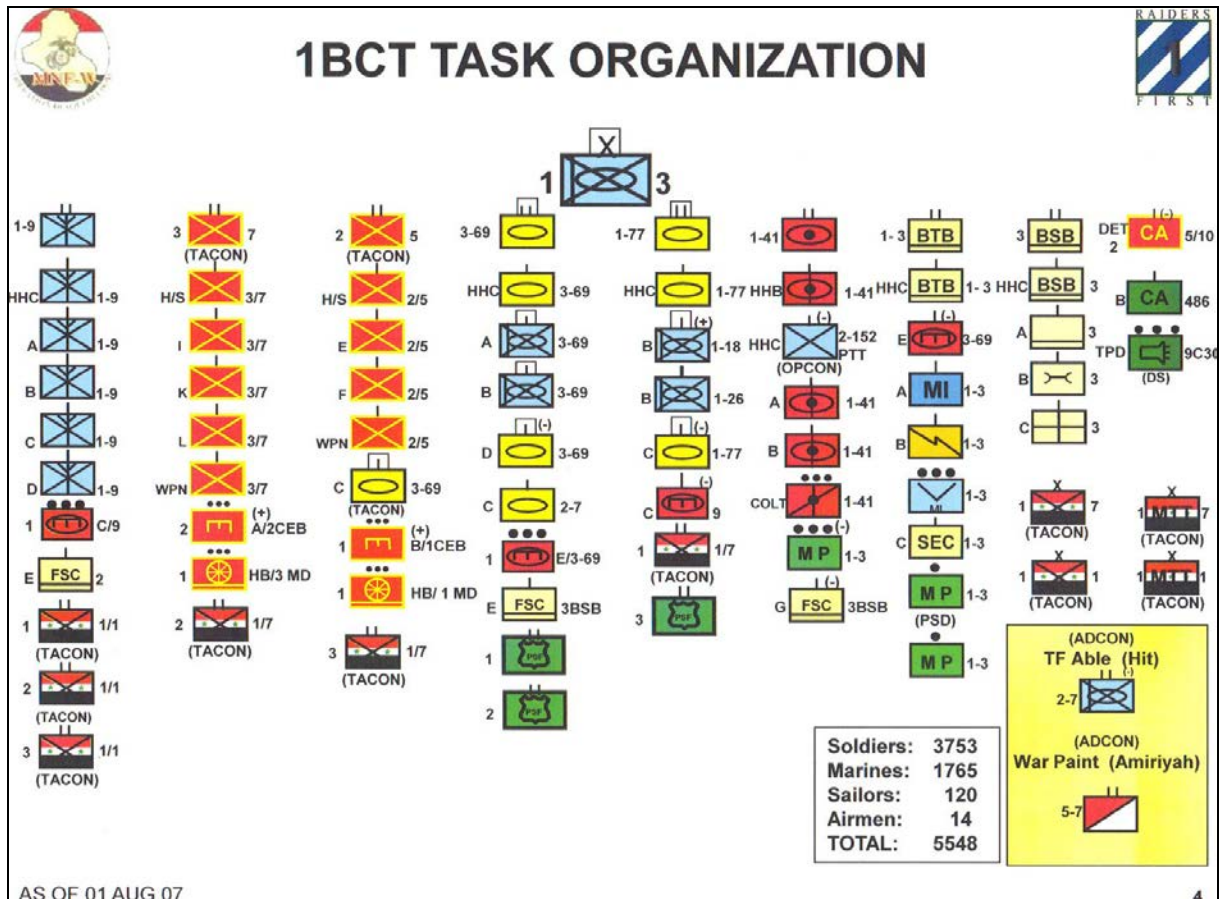

Figure 3. Raider Task Organization as of August 2007 (Courtesy COL Charlton)

Knarr: When did General Odierno come out?

Charlton: Oh, it was probably late March or early April. It was very soon after we had it cleared. Once we said it was good to have the Corps commander come through the neighborhood, he wasn't a stranger. Regardless of what the situation was, he was always out there. I want to say it was April. General Petraeus came out very early, too, because they knew we were doing these operations. They wanted to see how it looked. All you had to do was take them walking down the streets of Ramadi without being shot at and that told you there was something significantly different about the situation. I think General Petraeus went and bought ice cream at one point in this one corner.

Knarr: Was that the video that I saw? I saw a video of you walking in the souq.

Charlton: Yeah, that was later on. That was one of his last times. That was months afterwards when Ramadi was completely transformed from this terrible battleground to flourishing city. [Figure 4, 5 km run in Ramadi in September 2007]

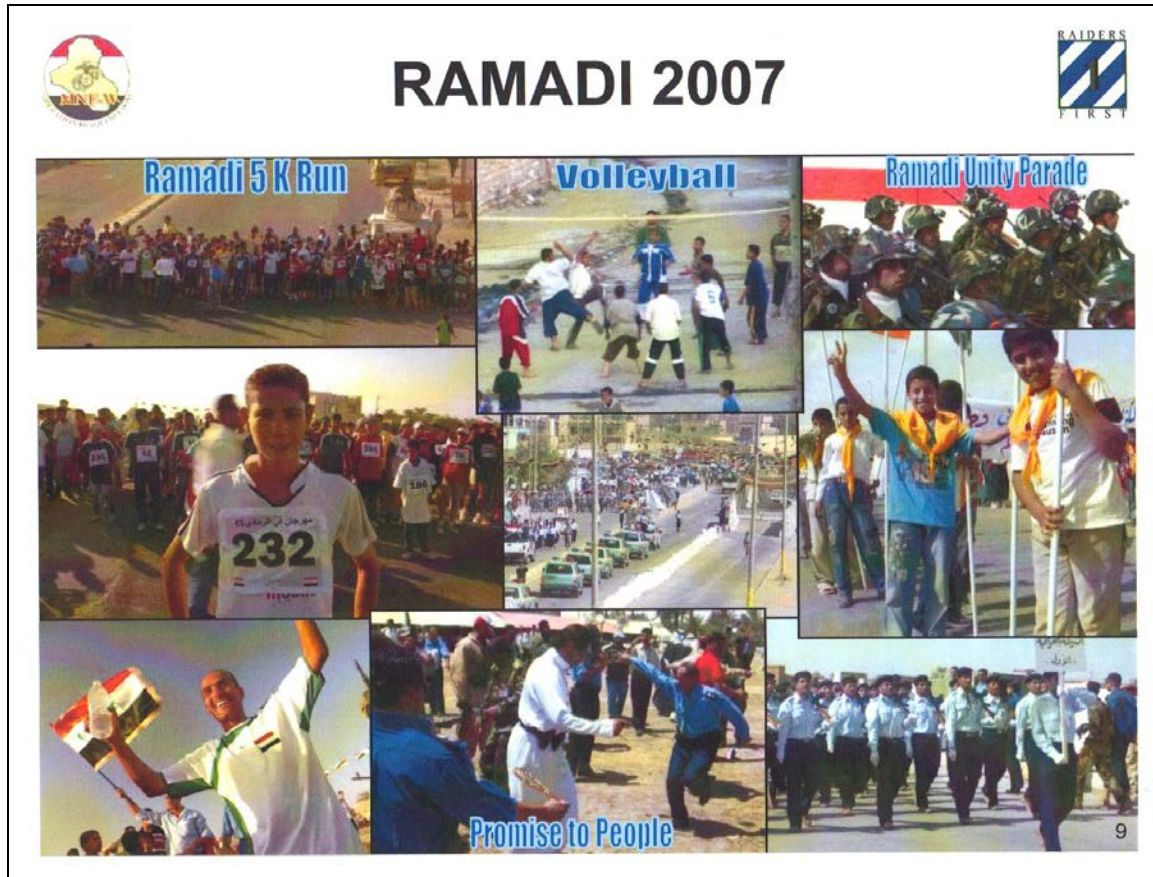

Figure 4. 5 Km run in Ramadi 2007

Knarr: During this time, you go in and cleared, but then you are also doing the engagement or right afterwards. When did you start meeting with the tribal leaders? [40:07]

Charlton: Well Sean MacFarland took me out to meet all the key leaders during my PDSS. I met Sheikh Sattar, who was one of the founding leaders of the whole Awakening movement, the *Sahawa*, as they called it. His house was literally right across the street from Camp Ramadi, so you saw it every day. We were over there all the time and developed a very strong relationship with him. It's really hard to adequately describe how important that was, not just with Sheikh Sattar, but with all of the tribal engagements, because it allowed us to generate police forces and Army Forces.

I remember talking to some of the Military Training Teams that we had there working with the Iraqi Division in our area. It was a Marine Training Team. They were responsible for working with the Iraqi Division Headquarters and had been really trying to develop recruiting and to get recruiting going in the area. But the problem was that up until then the tribal leaders didn't support joining the Army. So if they recruited a handful of guys, they considered that a pretty good day. So, we said, "Well, let's do it again." It was coming up time for another recruiting drive. So we had our engagement with Sheikh Sattar, and we said, "Hey look, all this hard work is going to go to waste if we can't get the Army built in Anbar. I know there have been problems with that before, but we really need your help on this." He said, "Look, we'll do it on one condition. I don't want to have these young men of Anbar getting sent off to some Shia community where they're going to be slaughtered." There was still a great deal of sectarian tension. So, he said, "I will support this as long as you can promise me that for at least one or two years these men will serve in Anbar." And we said, "Ok." We send that up. It got up to General Petraeus and he said, "Yes. Consider that done. We'll work that with the MOD." Word got back, and he said, "Ok I'll help you. I'll do everything I can." And of course right then he's made a commitment, and his pride was on the line. It was unbelievable. We had literally over a thousand young men show up for recruiting. The Marine Team that had previous gotten a handful of guys was maybe expecting 20 or 30 when they saw hundreds of these guys coming in. They were like, "Whoa! We don't have enough slots in the basic training for these guys." I was like, "Oh, wow, ok." We did not expect a runaway success or overwhelming success, so we had to tell a couple guys, "We're going to hold on a few weeks, and we'll get you into the next course." But that just demonstrated the power. And then we did a subsequent one maybe three weeks later. We were a little more organized, because we said, "Ok we're going to get a lot of guys, so let's set this up better." And so we worked really hard with the Marines. The Marines worked very hard with the Iraqi Division to get a really good recruiting system set up, screening.

Knarr: Was this 7th and the 1st?

Charlton: 7th Division at this time. So we cordoned off a part of Camp Ramadi. We basically set up a recruiting depot so we could do the screening, the interviews, and have the doctors check them out and all of that. These guys come rolling in, literally, by the truck load. I mean they are coming in by the truck load. This is an image I'll never forget. Again our camp is right next to Sheikh Sattar's house. He is out on the road on the

highway, and he's cheering these guys as they come through the gate. And they're, of course, you know they're just beside themselves, because here's Sheikh Sattar, this hero of Anbar and they're cheering. It's like, "Wow, this is powerful! We've got to keep this guy on our side, because he is a big deal!"

Knarr: When did that happen?

Charlton: May, I think. [44:25] Yeah. This whole Awakening movement just was like a tidal wave building. In the beginning, a lot of folks who really thought they understood the whole tribal structure of Anbar did not see this coming. Because who is Sheikh Sattar? He's some kind of lower tier sheik. He's not very reputable according to some of the bigger sheikhs. But he had such tremendous charisma and such a powerful personality. He also helped introduce us to all of the other tribal leaders and so we went to him for guidance many times on, "Hey how should I approach this tribe and this sheikh?" We had a very close relationship that allowed us to then continue that relationship building across the area. And we used to track it as did Sean MacFarland. We would track the areas where it was kind of red, amber, green in terms of tribal relationships. And where he had gotten green about a third of the way across, I had to get the green all the way across. We just continued to do that. And as that spread, this whole Awakening movement spread. It became a political organization.

Knarr: You brought something up. You talked about opening three doors: the sheikhs, the Imams, and reconciliation. Then you said "From west to east."

Charlton: Yeah. Well it kind of goes back to the whole relationship piece. It took me my third time in Iraq to start to put this together, because I'm a Cold War product like most of my generation. This whole COIN thing is discovery learning in many cases. But it's about relationships. What I saw going on with MacFarland and Sattar and all these guys, it really opened my eyes to a lot of, "Ok, this seems to work." You know? And I got to the point where I would tell new leaders that were coming into the area, "Listen, it is about relationships. And your relationship with the population is your force protection. And it's going to protect you more than any amount of kevlar and any amount of concrete. Because if you've got a relationship with that population, they're going to have a vested interest in keeping you safe, because you're partners with them, you're friends with them, you have a relationship with them and you share a common interest. It's a building block of everything we're doing here."

Now we had always proceeded to have very strong relationships with the government leadership at whatever level. We understood that. Everybody gets that. You've got to do that. And police forces and security forces. Oh sure, you've got to be friends with the brigade commander, your counterpart. Everybody gets that. So why don't we have a good relationship with the population? Well, because we weren't going through the right door. At least in Anbar and I suspect in many parts of Iraq and throughout that region, because of the type of culture and society they have, you don't just go up and strike up a relationship with the guy on the corner. He's part of a social structure that's based in that area around a tribe and it flows through the sheikh or one of the sheikh's key lieutenants. So, here you go. If you want to try and establish a relationship with this population, you've got to go through that door; that's one of the doors you have to go through. That social structure is very, very important. Now, when I walk into a big gathering of Iraqis and I'm sitting on the right side of sheikh Sattar and we're clearly friends, that's a powerful message.

I've got instant street cred in Ramadi and that helps. That really helps. I've got more stories that demonstrate how that literally saved my life in some cases. Like I said, it's the best force protection you can get. The normal doors are the ones we always get: the security forces and the government forces. The other door is the elected or appointed officials. That's obviously a door that you can't bypass. The only problem was for a long time that was our biggest focus, and we didn't focus on the tribal leader door. And then the third door... what else is important in this part of the world? Religion. And I didn't learn this, I didn't pick this up. I was only smart enough to realize I was being given a signal by Sheikh Sattar. He introduced me one time to three of the real key religious leaders in Anbar, the three key clerics in Anbar. They have a structure whereby there is a hierarchy within Islam at least in Iraq as they way I understand it. So these three clerics had certain authorities. And so Sheikh Sattar introduces me to these guys. Right off the bat, I noticed that they're pretty good guys. They're what we would consider moderate and what they considered normal, but they're not extremists. There was a method to what Sattar was trying to do here. He's trying to teach this dumb infantryman that Muslims aren't bad people. And Imams are not bad people. They're in fact greatly respected by the Iraqi population, and if you want to have acceptance by the population, you need to be accepted by these guys and have a relationship just like you do with the tribes. So, he was astute enough to get that. And after he stomped his foot and got my attention, I started to catch on that this was important. And it's not only important

because it gives you a relationship with the population, because, again, if I'm walking into a big gathering and I've got Sheikh Sattar on one side and I've got this highly respected cleric on the other side, I've got massive *wasta* now.

But it also gives you a very powerful tool in combating terrorism. Because you have now something at your disposal to attack the Al Qaeda or the terrorists *takfiri*-type ideology. That's their main tool. When Al Qaeda moves into a neighborhood, its first stop is at the mosque. It's their ideological base. They will try to take whatever ideology is being preached to that mosque and replace it with their version. They'll either do it by coercing the Imam, replacing the Imam, or just bypassing the Imam and broadcast their own sermons on Friday over the loudspeaker. There's a lot of ways they do that. They use that as a recruiting base because everybody goes there. They get like minded individuals who are vulnerable to support them there. [51:58]

So how do we fight that? How can American Forces or even Iraqi Security Forces deal with that? It's pretty hard. But not if you have a great relationship with the key clerics in that region, because then they can help you with that. Because you now have a mutual interest to keep that kind of ideology out of the neighborhoods. You want to have the proper, the normal, the respected version of Islam being preached in these neighborhoods. And that's what these gentlemen wanted. That's what we wanted. And so you form a relationship with them.

Now, if you have a problem in the area that you can trace to a problem in a mosque, I now have something that can be used. I go to these friends of mine and say, "Look, we go around on Fridays, you know we do this, and we listen to what's being preached at the mosque. It gives us an indicator of whether there's going to be a problem in these neighborhoods. Now we have all shed blood, sweat, and tears to get these neighborhoods cleared. Yet now we're concerned that there's something going on in this neighborhood, at this mosque, that's going to throw that all away." And they'd say, "We got it. We got it." In fact they would usually criticize us for not coming to them sooner. We would usually wait a week or so before approaching them. If we thought we heard something in a mosque sermon that concerned us, you know, messages like, "Kill Americans" or "Don't support the Iraqi Police," those types of things would come back to me as a negative report. We would usually wait a week or two to see if we got the same message. Maybe the Imam woke up on the wrong side of the bed that day or maybe, you know, an American did something that made him mad. But we would confirm it. I would usually wait two to three weeks before I approached our friends and say, "Hey, we have a

problem.” They would yell at me for not coming to them sooner, because they did not want that kind of thing. And they did a number of things. In some cases they would go in and council the Imam or they would censor him. Or in some cases they would say, “This guy is from out of town,” and they would throw him out.

Knarr: And then make sure he was out of town. [54:10]

Charlton: It was amazing. So that’s door number two. The three doors that I identified were the tribal leadership, the religious leadership, and then this idea of reconciliation. And again, I didn’t arrive on this on my own. We all understood. All of the US leaders in Iraq understood that there was a fundamental problem in Iraq that was centered around cooperation and reconciliation, whether it was Arab/Kurd or Sunni/Shia. Iraq had been run by the minority sect, the Sunni population for a long time. The Kurds had been repressed. The Shias had been repressed, so there’s always bad blood kind of like in the Balkans. So we were all trying to grapple with that and come to grips with that, but you’ve got to be very aggressive about how you do that.

In the case in Anbar, what you had to try and do was get all these ex-Ba’athists to no longer support the insurgency. And a lot of them really were only wanting to rejoin their role in society. They didn’t necessarily expect to be put back in as a division commander in the Iraqi Army, but they did want to be able to collect their pension. They did want to be able to go home, live in peace, and not worry about being harassed or persecuted even though they may have done that in the past, but that’s what they wanted. And so, again, orchestrated by some of our tribal friends, they would help arrange these meetings where we would talk to these guys and get them on board. That was another door you had to go through. Otherwise you’re going to have a segment of the population that’s very influential, again, because at least in Anbar these guys were pretty big guys. At one point they held a lot of influence, and they’re still very influential. And so that’s something that we had to work on. Again, I didn’t arrive on that on my own conclusions, but it was explained to me very clearly by folks we had formed relationships with there in Anbar.

Knarr: As you moved out east of Sofia it seemed like everything was kind of close then all of a sudden. I don’t know, maybe I have a misperception, but reach beyond Sofia to the east to the Fahad, that was a big deal. Can you talk to that?

Charlton: Yeah. Well, I remember talking to Sean about this. The Fahad tribe was probably the dominant tribe in that area of Anbar. We were concerned that you had this western tribes under the Albu-Risha tribe or aligned with them, the Sahawa movement. But the

Fahads were a pretty big tribe and they may or may not want to be seen as being subordinate to that whole movement. We thought there might be some friction there. So we were wringing our hands on how are we going to do this? We need to talk to the Fahad tribe. We need their support. They're probably not going to get along really well with our friends from the west. How do we do this? And finally I think I went to Sheikh Sattar and said, "Hey look, would you be interested in going to meet the leadership from the Fahad tribe?" He said, "Oh yes, absolutely!" I was really surprised. I thought he was going to look at me funny, but he wanted to. And so I worked it through Colonel Ferry to set the meeting up and get the Fahad leadership there. To tell them of course that we were bringing Sheikh Sattar and then we would show up. So we did. And again, a great example of Sattar's power of personality, he was greeted like a rock star. I mean it was just amazing. It really caught us off guard. We thought this was going to be one of those really tense moments where you didn't know what was going to happen, but these guys were just overjoyed. And I think it was really just a common feeling of happiness that they'd broken free from this Al Qaeda yoke that had been around their necks for so long. And they realized that there was a great deal of respect now in both directions on what they'd been able to accomplish through leadership. [59:18]

Knarr: Your development, your EPRT [Embedded Provincial Reconstruction Team], your work with USAID, what is it called the stair step economics...?

Charlton: Oh yeah.

Knarr: Can you talk to that?

Charlton: Right. Well this gets into the whole build thing.

Knarr: Yes, now we're ready to build.

Charlton: We're in the build. And so Ramadi looks like East Europe 1945. I mean literally I remember the first time I drove through, there was no building that hadn't had at least had one tank run through it. Complete sections of the city were rolled, including the center part of the city right next to the government center, a pile of rubble. There was standing water and a lot of standing sewage, because every time an IED went off, it ruptured a water line or a sewer line or whatever. It was just a mess. It was an absolute disaster. And you're looking at it like, "Well, how do I deal with this?"

The first thing we figured out was we've got to clean the place up, you know? It was just a disaster. We've got to clean it up. This will have a number of effects. It will have the

practical effect, because we're going to pay the Iraqis. We're going to use CERP money to do these day labor projects. They're going to be very simple. We're going to let the company commanders control it. We're not going to try and centralize it, because that will slow it down and make it not work. And in counterinsurgency you've got to really decentralize. You've got to empower and resource your junior leaders to make it work.

And so, you know, "Ok, go clean your neighborhoods up there company commander. Get with your tribal leadership. Here's some money. Go make it happen." And you know, you give a young Marine or Army company commander a mission, they're going to go do it. They're going to figure it out. So these things take off. You get this ripple effect, because you decentralize and you push the money down. And now you've got your economic stimulus plan going in a big way. So we would show a slide of before, during, and after. Of how this horrible scene, this certain neighborhood just completely turned around. It's urban renewal from the ground up. So that's good. And now guys got some cash in their pockets and they can go to the *souq* and buy tomatoes. They can feed their family. And that's good. And so everybody starts feeling really good about the situation more than psychological separation.

But it's a short term thing. That's the bottom step. You don't want to continue that, and you're not going to continue that because you don't want to create a welfare society. So that's a very short term thing.

And so the second layer, is that you want to get some of that entrepreneurial spirit going. You want to get the *souqs* up and running. You want to get the bakeries going. And so you've got to figure out how to get the next economic layer going. And we did that through a variety of programs that worked with USAID, micro-grants, micro-loans. And there's a very strong entrepreneurial spirit in Iraq. I mean tremendous. Working with USAID, we also built an economic business center, because we figured if you want to get economic activity going then you need to have a gathering place. You need to have some place where you can go and talk about that and have seminars on how to get contracts with the US Forces, for instance. And how to write up a contract and that sort of thing. And so we did a lot of that and computer skills training. And that worked very well.

And then you kind of take it up to the next step, which is you eventually get it to where you're at the manufacturing level and you start looking for the big employers. We had a glass factory and a ceramics factory in Ramadi that were a focus in that area. So, you

kind of have to hit each of those levels to get things going. Now, where the EPRT came in is it gave you access to some resources that you don't have obviously within the Brigade Combat Team. You have a lot of really smart people that know a lot about banking. They can help the Iraqis get their banks going. They can help the local government balance their budget, that sort of thing. You have folks that are experts in essential services so they can work with the Ministry of Water and the Ministry of Electricity to help getting essential services going. Here you are now. You have this team that's ready to go to work, so how do you make that work?

Kristen Hagerstrom was the EPRT leader that worked with me. They showed up and there was a memorandum of agreement between the Department of State and Department of DoD on how this program would work. We all read through that. I had certain responsibilities. I had to move them, secure them, feed them, and basically provide all their levels of support and work with them. But it didn't say how to do it, you know, so we had to figure this out as we went. And these were the first ones. This was the first batch of EPRTs. So I talked to Kristen about it, and I said, "Look, what we've learned about building police forces and military forces is you can't make it your day job. You can't leave the FOB, go out there during the day, and then come back to the FOB. You've got to partner with them. You've got to live with them. You've got to develop that relationship, so you can have candid discussions and make things better and have a really good understanding of their problems."

So what we did was we built them a compound right next to the Government Center. We said, "Like I have my police trainers living at the police station, you're not going to live down here, but you're going to work down here during the day." So we built them offices, and we structured it so that they were working side by side with their counterpart in the municipal government, so the EPRT team that was working on electricity was sitting, literally, right next to the mayor's representative for the Ministry of Electricity or Water. So they were meeting all the time and had regular interaction and communications and building that relationship. So that's how we leveraged the EPRT and how we integrated them into the effort. [1:06:47]

The other thing that they did was there is always USAID Senior Representative on the EPRT. I didn't know very much at all about how USAID worked, but I got to understand a lot better about how they work and some of the programs they have and how to use them. One of their most successful programs that I saw that worked very well for us in central Anbar was the Community Stabilization Program [CSP]. It was structured very

much like CERP, but the CSP was fairly controversial, I think. Based on my understanding it was unique, let's say, for USAID, because it didn't focus on long term development, which has always been the staple for USAID, the long term development programs. Because what they're trying to do is build capacity, so they focus on the long term and that makes a lot of sense in developing countries. But in a combat environment, in a COIN environment, where you're area is in ruins and nothing's working, you've got to take, at least initially, a little bit shorter term focus.

This is where CSP came in. Because, like us, they were focusing on how to get the water running, how to get the bakery back in operation, or how to fix the street—those basic level things. And so we learned how to complement their efforts. They could do things that we couldn't do with CERP. With CERP I could refurbish a building. I couldn't build a new building, but if there was just one wall left on that building, I could get a contract to put the other three in and a roof on it. But if it was an office, I couldn't put any workers inside of it. I couldn't do that kind of stuff. I couldn't hire staff, you know. I could only fix things, make the plumbing work and that sort of thing. But they could with CSP.

And so I worked with a gentleman named Travis Gartner, who worked for the implementing partner that was running CSP. He was a young guy, very aggressive. Just like one of our company commanders out there, he had a mission and he was passionate about seeing it through. So we learned how we could make CERP complement what he was doing with his money, because he could hire staff and do things like that. One example was the business center. We refurbished the building, and he bought the computer lab that went in there and hired the staff of Iraqis that trained other Iraqis on computer skills. Another example was a trade school. It had been a trade school before, but there had been a tremendous amount of battle damage. It had been looted. I fixed the building, he hired the staff, he bought the machinery, the electrical and the plumbing. He bought all the stuff that went inside the building and the staff and the teachers. He hired them. And so we did that project together. Neither one of us could have completed that project separately, but working together we were able to do that. It encouraged him to get to know our battalion commanders and our company commanders. He could walk into any of the Combat Outposts and Joint Security stations. He knew everybody in there. His team knew them. Again, it's about relationships. [1:1029]

Once you get that ball rolling as a brigade commander, all you've got to do is stand back and let it go. By doing things like that, we were able to take this worn torn city that was

a pile of rubble when we got there and change it so that by the end of 15 months, you'd never know there was a war fought in this town. One of the presents I got, you know, you always get a going away gift from your units. There was a Marine Civil Affairs Unit that was leaving and their gift to me was this picture of Ramadi that they had taken from a helicopter. It was just simply the main thoroughfare going through Ramadi that had been completely transformed and rebuilt. And if you didn't know anything about the story of Ramadi that wouldn't mean a whole lot to you, but it meant a lot to me because I knew what it looked like beforehand.

Knarr: That's incredible. You know at the beginning you mentioned getting your IP support, you get your Army, but you've got to get the sheikhs to be able to get to the people to be able to recruit them. I know that there was an ongoing effort in Jordan to be able to reach out to the people. We talked to General Reist. He was over in Jordan trying to make this work and you're back in Ramadi on the ground trying to make this work. I know that the arbiter of this had to be probably Zilmer or Neller or somebody. I know there was probably angst over how you really do this?

Charlton: Well, yeah, I think it was just a different approach. You see a lot of the principal tribal leadership prior to 2003, the key tribal leaders, you know sometime after 2003 got the heck out of there, because it was just too violent. And a lot of them had business connections in Jordan, and so that's naturally where they went. And so they were kind of ex-patriot sheikhs, but they were the only ones at the time that you could safely confer with and had similar interests that we did. They wanted to get back into Anbar. They wanted Al Qaeda out, so they could come back in Anbar safely. And so it provided an opportunity for engagement. And because they were in fact the big power brokers, it made sense. It was the right thing to do. Even though they were not in Iraq, they were still very influential. They still had a lot of connection. So if this is the only tribal engagement that you can get and they are very important guys then it makes sense. And so there was a lot of effort spent by General Reist and then General Allen subsequently to do that.

At the same time, Charlton can't take a trip to Amman. I didn't even bring any civilian clothes, so that was a little rough. All I've got is what I've got. But I've got a sheikh right outside my door, and he's a pretty good guy. And you know what? I take him to see the Fahad's and he's a pretty popular guy, so I'll work with that. So, I'm working with the riffraff around Ramadi, but these are the young Turks, so to speak. They're the up and coming, new generation. And they've got the *wasta*, the influence, the respect

earned, because they're out there fighting Al Qaeda, and that was their narrative. "Hey we didn't go to Jordan. We stayed put. And yeah, we lost members of our family, but we stayed put and we fought Al Qaeda." And in Anbar, family hierarchy and tribal hierarchy only goes so far. You have got to have the respect of the tribe and have proven yourself as a leader to claim that spot as a sheikh. And so this new group of Awakening leaders are gaining a whole lot of respect. And we were also seeing that they were producing results. I've got Sattar out there on the highway waving trucks full of new recruits coming in. I'm not seeing these guys from Amman doing that. And he's introducing me to former Ba'athists who want to reintegrate back into society and are just looking for ways to get their pension. I don't see any guys in Amman doing that. And you know, I could go on and on, but that was the different perspective. [1:15:20]

So you needed to do both, because the guys in Amman, while they may not be able to pull truck loads of guys into your recruiting, they do have a lot of economic ties and business ties, so they can help you with that. Maybe help you get some additional foreign investment coming in, banking. That's the angle that General Reist and General Allen were working at the higher level. I'm just working about filling police stations, but they're actually trying to get some economic development, maybe some broad term reconciliation going on, that type of thing. So they're looking outward, which is exactly what they need to be doing. And I'm focusing on my little problem set inside of Central Anbar. I think together that worked pretty well. It's not that one was right and one was wrong. They're both complimentary and at different levels.

Knarr: ISR? Intel. We talk about Intel Support Teams for the Army, Company level Intel teams for the Marines and you understand this concept is from the bottom up. But then I see something like the Devlin Report that says things are bad but I don't see anything in it about tribal engagement and he was the senior Marine Intel officer in Iraq. The Army's intel apparatus is different than the Marines. They have the two intel battalions that they're working in Al anbar. One as SIGINT [Signals Intelligence] and one is HUMINT [Human Intelligence]. And of course the Army, you had your own MI Company. What else did you have?

Charlton: I also had Marine SIGINT resources with me.

Knarr: When you say resourced, are you talking about the collectors or are you talking about the analysts or both?

Charlton: Yeah, I mean I had an element of Radio Battalion that had SIGINT capabilities.

Knarr: How did all that stuff work? How did the intel come down? How did the intel support you requirements? [1:17:49]

Charlton: Well, again, I think that when we started to move out and actually partner and live with Iraqis and become more integrated into society, obviously, you're going to get a lot more information coming, a lot more intel. And it's not just coming from your HUMINT teams. It's coming from company commanders, it's coming from squad leaders, it's coming from platoon Sergeants who are interacting with the population, and they're learning things. They're learning a lot. And then I'm out there talking to all sorts of people, and they're telling me a lot of things. And then you've got the other INTs there working. You've got your UAVs [Unmanned Ariel Vehicles] up and you've got your SIGINT working for you.

But for me, it was really about presence. I'll give you an example. We had cleared Ramadi and then we had worked really hard to clear the bands around Ramadi, because all Al Qaeda does is they just look for another little pocket to set up in. And yeah, they're not in the city, but they're sending car bombs in from the area just outside of the city. And we were getting a lot of that throughout the summer. And so you'd go up there, and you'd run an operation and nothing. You'd get a dry apple. It's like, "What's going on here?" And we used to get that a lot coming up from an area around Lake Tharthar, which is north of Ramadi and just south of Samarra. It's a seam between Salah ad-Din, Anbar Province, and Baghdad Province. And guess what? It's a seam between multi-national divisions as well. And there's not presence there: no Iraqi presence and no U.S. presence. According to the Iraqis, there's a lot of Al Qaeda presence. So, there's not a lot out there. There are some little villages and whatnot.

So we go run an op and nothing! Maybe a little. Maybe a cache, small stuff. And we do this repeatedly, and we're still getting car bombs coming in about once every other week from this area we believe. And again it's like, "Well, we're not getting the information. Nothing's happening." Sometimes you've got to step back and think, "Ok what's worked for us?" Well what's worked for us is when we go in an area, we set up, and we stay there. And we develop relationships with the community and we've got 1,000 beat cops out there running around, eyes and ears everywhere. You develop relationships with the tribes and you start to find out what's going on. And that's exactly what we did up around Lake Tharthar. This wasn't until like the fall of 2007. We actually did a major operation to clear the area, and we planted a flag. We actually built a base. It was an Expeditionary Base for an Iraqi Army Battalion. I had an armor company out there, and

we had some police. It started out as a battalion and then whittled down to a company. And sure enough, after we'd stayed there about a week, the enemy started to challenge us with IED attacks and all sorts of things.

And so now you get this kind of counterinsurgency campaign going on up there. Over time you develop relationship with the tribes, intel sky rockets, because you've got much better situational awareness. And pretty soon, Al Qaeda is driven out of there. And so we went through a great amount of effort to try and posture our forces so we could have the kind of presence that would allow us to get that bottom up intel. So I'm a big believer in that.

I also think we need to work a lot on our HUMINT capabilities. As a battalion commander or a brigade commander or as a commander in general, you're responsible for intel. Your intel office is not responsible for intel, he or she is the person that has that portfolio for you, but you're responsible for it. So if it's not working, it's your fault, just like everything else. So, you've got to take a much more active interest in this. I didn't learn this until later on. I just assumed that we had a pretty good source network. I assumed, "Hey these intel guys know how to do that." I get these reports, "Wow, they sound pretty good." But when you start to peel it back and you say, "Well, tell me more about your sources. Can you give me a demographic lay down of your sources? Kind of bin them by demographic categories? You know, how many university professors do you have? How many businessmen do you have? How many government officials? How many clerics do you have?" I don't need to know the details. Just tell me in broad terms, give me a fraction or a percentage of how broad is your demographic spread of your sources? Because I've got to be able to figure out where the gaps and holes are, alright?"

And you know, I came to find out that we'd gotten a little lazy. We'd relied very heavily on the Iraqi Security Forces as our sources. And I said, "Well, look, that's an easy one. That's low hanging fruit. I would hope you could call your counterpart a source or at least a source of information, not necessarily a collector, but come on!" So we need to work our recruiting efforts in other places and we need to get a broad demographic spectrum of sources. I know that's probably doctrinal, but I hadn't thought about that right away. It took me a while to figure that out. And so I started saying, "Ok show me what you've got and let me see this. Then show me the geographic disposition, alright. I know they're not just collecting from that area, they maybe going across town to get it, but generally speaking they're probably going to know more about where they live than across town. And so let me see how that pattern looks and lay that out on a map."

Then you also go, “Ok, now tell me their frequency and accuracy reporting and start grading these guys.” Which they do, but, “Ok, why are we even talking to this guy anymore? Throw him out and get a new guy from that neighborhood.” I spent a lot of time establishing presence to get that broad base of situational awareness in intel. And then really refining how we gather intel. And then the final phase of that is of course, teaching Iraqis how to do all that. That was a big challenge. They were very good at collecting and getting sources, but production and analysis and that sort of thing are a little bit more of a challenge. [1:24:31]

Knarr: Surge, did it help?

Charlton: Well I talked about why I really needed that Marine Battalion. I mean quantity has a quality all of its own. And if you want to have that presence. If you want to have enough troops to put in every police station and every Iraqi outpost so you can have that partnering effect, that mentoring effect, that just takes a lot of people. It really does.

Knarr: Did 2/5 come in under the Surge? You said the Iraqi Battalion...

Charlton: We all came in under the Surge, but we weren't technically what they called the “Surge.” I think 2/5 was a designated Surge Force. I came in during the Surge time period, but I wasn't technically part of the Surge. But yeah, I was there during that time period. You know we had always been in a position where you always want more people. But there's times when you really know you don't have enough. And that was 2006, 2007, and 2008. Those were the right times to have more people coming our way. Then combine that with the Surge, the real Surge, the important Surge, was the Surge in the Iraqi Forces that occurred because of things like Sons of Iraq and the relationships with the sheikhs that allowed you to recruit more.

Knarr: You talked about Travis Gartner, was he USAID?

Charlton: He was an implementing partner of USAID. In other words he's a contractor working under a USAID contract. The Community Stabilization Program is a program that USAID was using in Iraq, and he was young guy out there working for a contract...what they call an implementing partner doing this program. Yeah, so he's affiliated with USAID.

This is a briefing that is essentially unclassified. I show attacks and how we went from about 40. And these are the different operations. And you'll see a little spike when we're

doing a big operation, but then you notice it drops down a notch, down a notch, down a notch. And so you can see it's pretty dramatic. [Figure 5 and Figure 6]

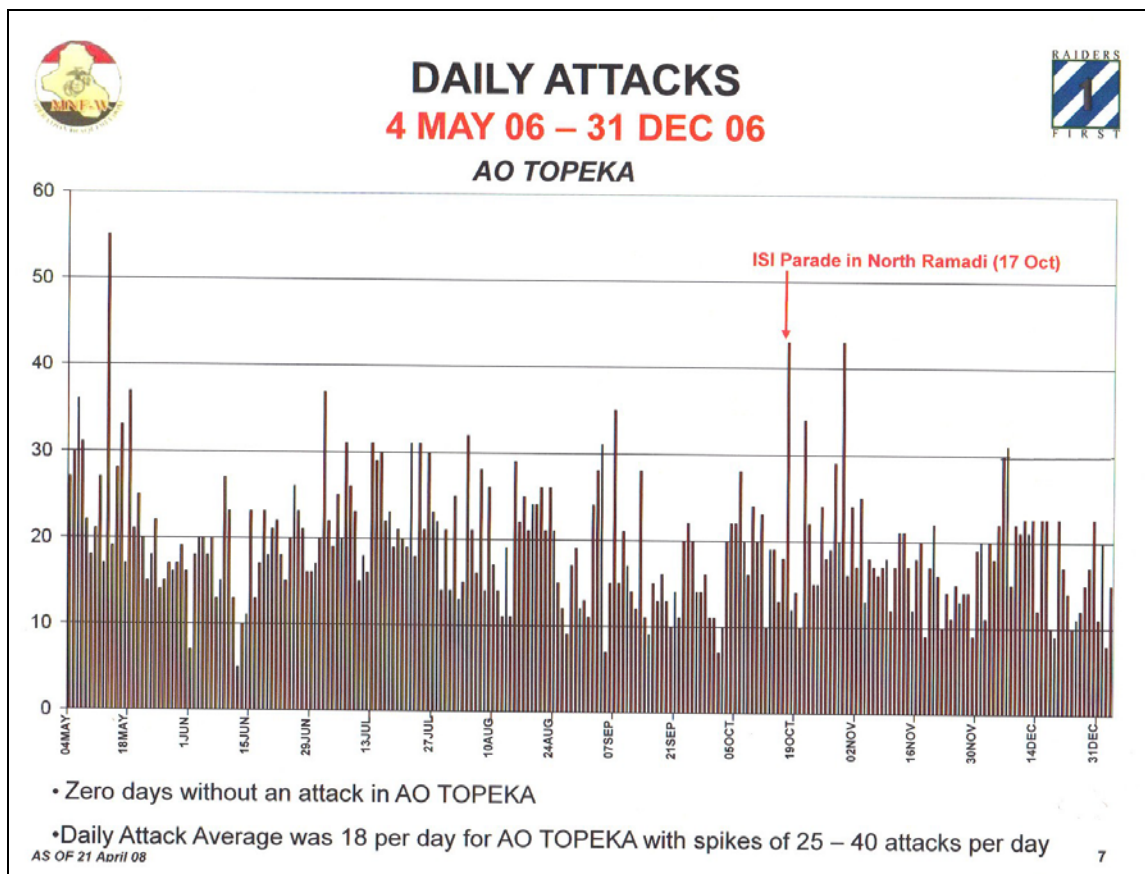

Figure 5. Daily Attacks 4 May 06 to 31 December 2006

Knarr: It sure is.

Charlton: That's the area writ large. This is Ramadi proper. And you can see 31 March is like right there and you can see it literally falls off to nothing. And you get these little spikes, and then eventually we were going weeks without a single shot fired in Ramadi. This is kind of the enemy's situation, daily attacks. This is the Devlin Report. All of this is very, very accurate, the state of the situation in Anbar 2006. This is what Ramadi looked like. This is the level of the destruction. So I can leave this with you. If there's something in here you think you need, I can send you the electrons. Oh, wow this is how we cleared Ramadi, some symbology and the surrounding areas. Ramadi Security Plan, I didn't talk a lot about that, but you know part of the hold is this idea of protecting...they did this in Baghdad in 2007/2008. This is where concrete helps. We literally walled off Ramadi,

and tried to make it very hard to get into Ramadi, but once you got in to Ramadi, you could move around freely for the most part. And that supported economic development. But anyway, I think everything in here is unclassified.

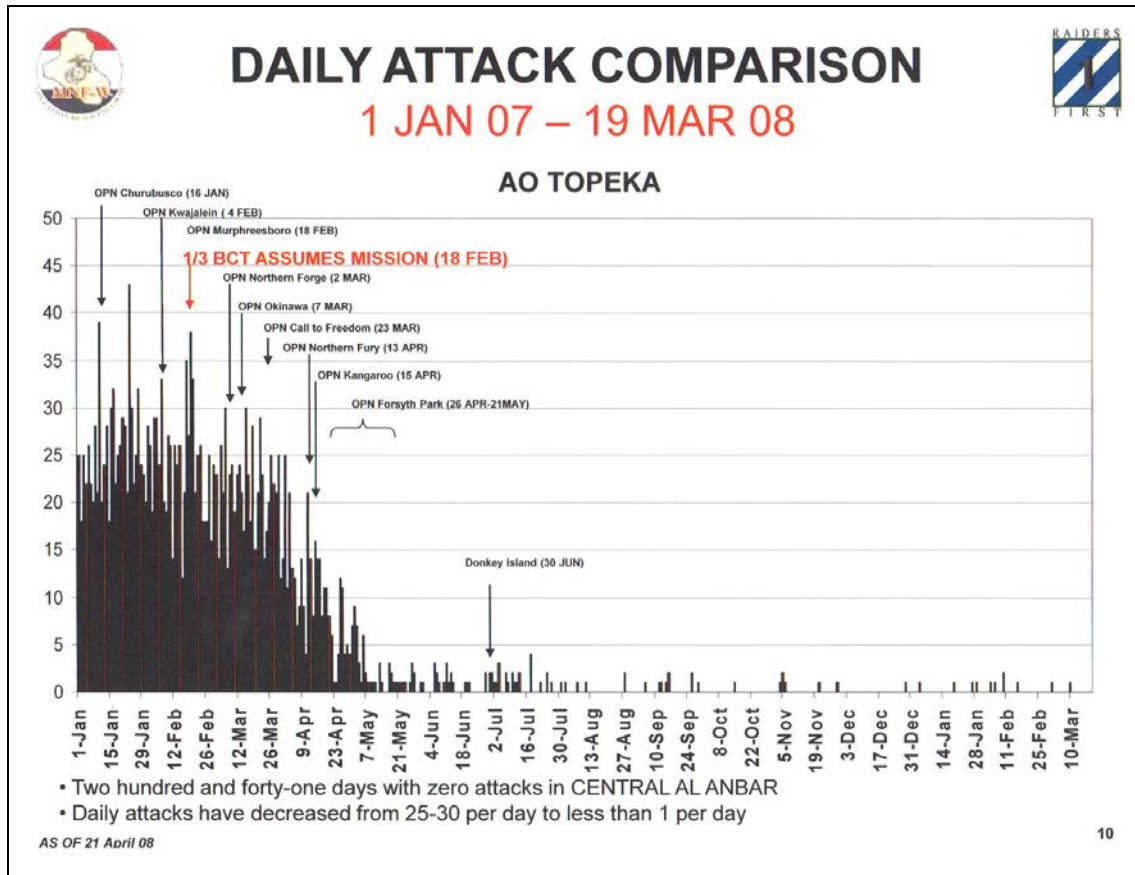

Figure 6. Daily Attacks 2 (Courtesy COL Charlton)

Charlton: I've got more on the ones that you talked about, the Stair Step Economic thing. That's in one of my PRT briefs I think.

Knarr: That would be great.

Charlton: I can send you that. So I'll leave that with you. Last year or the year before I was going over to the Foreign Service Institute there in Arlington and briefing the PRTs about what it was like to work with a BCT.

Lieutenant Colonel David Graves: You had like a really good relationship with Sattar. They open doors and showed you different people that engaged. When he died, did you have the same type of relationship with his brother?

Charlton: Oh yeah, Ahmed. Yeah he continued. I was obviously there right after it happened. I knew Ahmed very well. I'd mentioned Sattar just because he was the big guy, but Ahmed was right there by his side. In many cases, Ahmed was kind of the brains behind the scene, the organizer. Sattar would go off a lot of times, and I'd be talking to Ahmed. And then of course after Sattar was gone, Ahmed becomes the primary go to guy, but Sheikh Muhammad Heiss is another key figure.

Knarr: We didn't talk to him, and I wish we would have. I've heard he was very, very good.

Charlton: Phenomenal. That was one of the relationships that saved my life. We had an incident where one of our troops got in an altercation with an Iraqi police in the middle of the night. It ended up the Iraqi policemen was killed. Obviously this was a huge tribal problem. He helped us through that and helped me through a couple really, really dangerous situations. He advised us. There were a lot of guys out there that probably wouldn't have made it through without their help and advice.

Knarr: I appreciate you taking the time. This is great. Thank you.

24 January 2013

Subject: Interview with Colonel Miciotto “Bear” Johnson, former Commander, 1st Battalion, 77th Armor [1-77 Armor] in Ramadi, October 2006 to November 2007

Colonel Miciotto “Bear” Johnson commanded Task Force 1-77 Armor in Ramadi, October 2006 to November 2007.

TF 1-77 deployed to Kuwait in August 2006 as part of the CENTCOM Theater reserve, also known as the Call Forward force. In September they received orders to deploy to Ramadi and replace TF 1-35, commanded by Lieutenant Colonel Tony Deane. Within 48 hours of arrival, TF 1-35 and 1-77 with Marines and Iraqi Army and Police were clearing an area of Tameem and constructing a combat outpost. During their tour in Iraq, TF 1-77 continued to improve their area of operations



by expanding security as well as conducting key leader engagements and developing / expanding the economic and Governance lines of operations. Colonel Johnson witnessed the Awakening movement progress from Ramadi, to Al Anbar, and to Iraq – the Sahawa Al Iraq. COL Johnson was interviewed on 13 October 2010 at his office at the Training and Doctrine Command (TRADOC) Capabilities Manager directorate for the Virtual Training Environment (TCM Virtual) at Fort Leavenworth, Kansas.

Dr. Bill Knarr: You are Colonel Johnson, they know you as “Bear” Johnson, and I’m sorry, your first name?

Colonel “Bear” Johnson: My first name is Miciotto. Everybody calls me “Bear”. My middle name is O’shane. So I have an Italian first name and a Scottish middle name.

Knarr: And your current job?

Johnson: I’m the Director, TRADOC Capabilities Manager (TCM) for virtual simulations.

Knarr: Please provide some of the background information before deploying to Iraq.

Johnson: I was assumed command of 1st Battalion, 77th Armor (1-77 AR) in June, 2005. We were alerted that we would re-deploy to Iraq. At that time we did all our initial training at our home station in Schweinfurt, Germany and culminated our deployment prepara-

tion at Grafenwoehr and Hohenfels training areas in southern Germany. We conducted that training starting in August with platoon lane training, progressing to Gunnery, and culminating with a MRX [Mission Readiness Exercise] that ran between January and March, and an additional Gunnery, which focused on our dismounted and HMMWV based skills. It was actually a multi-echelon approach where we trained and certified on our tanks and Bradley's and also our HMMWVs; this allowed the battalion to deploy dual platform capable crews, which was a major aspect of our MRX and our Gunnery. That ran until March. We conducted our PDSS [Pre-deployment Site Survey] on the backend of the MRX. That was initially to Ramadi, because initially our brigade was scheduled to replace the 2nd Brigade, 28th National Guard Division in Ramadi.

Between the end of that PDSS and our actual deployment, which was initially set for June, we received a FRAGO [Fragmentary Order] that said we would not go into Ramadi, but Kuwait instead; temporarily as a reserve. We subsequently deployed on or around the 25th of August, 2006 and established a base camp in Kuwait. Once we arrived in Kuwait our Task Force (TF 1-77 AR, STEEL TIGERS) received an additional FRAGO that said we would now be detached from our parent Brigade. One of our sister Battalions would also go to Baghdad and work for another Brigade and our Task Force would be headed to Ramadi and be attached to 1st Brigade, 1st Armored Division (1AD). I'm just speculating now, but one of the reasons may have been that I was a Company Commander (94'-95') and also a Battalion XO (99'-01') in 1st Brigade, 1st AD. So, as I reflect on that experience, I have 14 total years in Germany, four of those years with that Brigade; so when you add it all up, it's actually just short of six years with that Brigade.

Knarr: That's a lot of time. So you finish up your PDSS and...

Johnson: We finish up the PDSS, and return to Germany, we load the trains [logistical equipment, and other vehicles], and complete our final preparations for deploy. We depart in August, and arrive in Kuwait and I'm told, "You're going to Ramadi." I seized that opportunity to take my initial staff and commanders on an additional PDSS into Ramadi and that's where I first met Colonel Deane, General MacFarland the Brigade Commander, and Colonel Deane took me out and introduced me to Sattar. [4:11]

When we conducted our first PDSS to Ramadi in March, 2006, it was evident that there was no civilian police authority in Ramadi. There had been efforts, but initial Iraqi Police training was conducted in Baghdad and that presented a problem to the predominately Sunni population in Ramadi. They viewed Baghdad as being totally controlled and

backed by the Shia Government, and whether rumors or confirmed, the thought process for most of the population of Ramadi was, “We cannot go to Baghdad because they will kill us”. So, that idea was hard to refute. And at the time, just before I arrived, there was an event that Colonel Deane may have talked about where Al Qaeda murdered numerous members of the Ramadi population. This stream of actions led to an event where they (Al Qaeda) actually kept a body for over a week after they killed him, which sparked a revolt of the tribes. This person was actually a relative to Sheikh Sattar, so they (the Sheikhs and leaders of Ramadi) gathered everyone up and said, “We’ve had enough.” As I can remember, when Colonel Deane took me out to Sattar’s residence, Ahmed was away, and the first council I sat in was held in their historic family house, which was much smaller and modest than the house you saw when you visited Ahmed. It was actually the green house in the back where the women now stay. But that room was full of Ramadi residents and as the Awakening first started, it began as the Awakening of Ramadi and then it spread to the Awakening of Al Anbar and eventually to the Awakening of Iraq. But it initially started with, I think it was approximately 22 to 27 representatives; I won’t even call them all Sheikhs, but representatives of the Ramadi community that said, “We’ve had enough of Al Qaeda. We understand that our future is in our hands and we need to be a participant.”

Sattar was very dynamic, he was very charismatic, and he was not elected but he was chosen to be the figure-head of the Awakening. So, he was able to influence the other Sheikhs to bring in young men from their communities to stand up and join the Police force. Initially, they did not endorse anyone joining the Iraqi Army, because once again the majority of the Military training had to occur in Baghdad. General MacFarland was able to localize initial Police training, still on the auspice that everyone that wanted to join the Police had to comply with two requirements: 1. The literacy rules; they had to be able to read and write, and 2. The application had to be processed through the Iraqi government.

We had the more rural area of responsibility (AOR) on the Western side of Ramadi. Between the Iraqi Highway Patrol, Iraqi Traffic Police and the Iraqi Police stations, we had eight Police stations in our AOR with over 1200 Police and we also oversaw / mentored the Specialized Police that Sattar was able to go to Baghdad and get permission to stand up. So, everything we did initially was supported by the Iraqi Government. [8:43]

Knarr: Was that the Emergency Response Unit, ERU’s?

Johnson: ERU's; right. Sattar went into Baghdad and he brought back uniforms for that first ERU. We partnered the first ERU commanded by Colonel Jassim. Very tall, I don't know if you met him when you were there; he is a very tall, charismatic and sturdy Commander. I am not sure how many of those Commanders are still there.

Knarr: So you had transfer of authority when?

Johnson: On or about 12 October, 2006. We came in, we executed our PDSS. The operation that you brought up earlier, "Dealer" was a joint operation between 1-35 AR and 1-77 AR. My soldiers had been on the ground approximately 48 hours before we launched that operation, but because of deliberate collaborative planning sessions, and detailed rehearsals, we were able to audaciously execute the mission in conjunction with Colonel Deane's forces. My forces, because we didn't know the area as detailed as Colonel Deane's forces, cordoned the area off and Colonel Deane's Forces actually executed the assault / raid. We conducted a joint reconnaissance during the initial planning phase; Colonel Deane and I went down, met the owner of the home (target house for the future COP), and negotiated the siege of that residence to establish a security base in Ta'ameen, which was our largest area of security concern.

Knarr: So how did "Dealer" turn out?

Johnson: "Dealer" turned out as a great success. We were able to establish the COP (Steel). Of course we had varied levels of resistance, but "COP Steel" remained there until we left, so for 13 months COP Steel stood steadfast in the middle of the Ta'meen district of Ramadi. Once we instituted localized control and security, our Iraqi partners were able to assume and maintain all security responsibility. Actually, when we installed a Police station in Ta'ameen, which was Operation Casablanca in January, 2007; that established an initial Iraqi governmental footprint (an Iraqi face) in Ta'meen. We knew that introducing an Iraqi face was crucial to instituting presence and change within the community. First, the US Military presence and then less than three months later, we instituted an Iraqi Police presence. Once they were properly trained, properly screened and resourced by the Iraqi Government, we executed Operation Casablanca, which was clearing the [white] apartments; a set of apartments overlooking COP Steel. Ultimately, we took the enemy's eyes away from them and eliminated his ability to over-watch us, and we installed an Iraqi Police station in their backyard.

Knarr: Was the Iraqi Police station then right next to the apartments?

Johnson: Yes, it was right next to the apartments.

And once we were able to put an Iraqi face in Ta'meen they were also able to interact with the local populous. We were able to establish Iraqi checkpoints in and around the [white] apartments, which for years Al Qaeda had used as a base to intimidate and control the locals. [12:22] So, we took that key terrain away from Al Qaeda. Once again, we instituted a US presence initially, closely followed by an Iraqi force that increased our intelligence and understanding through operating with and within the community. Once we got the Police online jointly operating, we found out where the enemy key terrain was, where his high ground was – the [white] apartments. I can remember requesting from General MacFarland to take down the [white] apartments in November and he said, "You have to wait. I've got more resources committed elsewhere." I asked him again in December... "You've got to wait." He finally allowed us to execute the mission in January and I think, in my opinion, that's when, at least on the west side of the canal, the tide turned. Because not only was Al Qaeda using the [white] apartments as a base to intimidate and control the western side of Ramadi, but it also gave them quick access across the canal to infiltrate into the eastern side of Ramadi; so, they'd go execute an attack and then return quietly across the canal or bridge back into the [white] apartments.

Knarr: That makes sense.

Johnson: So, all along I was getting Intel from Sheikh Sattar because I would tell him, "Ok, you want to be part of the solution, where are they?" And he told me, "The [white] apartments."

Knarr: So you have "Dealer" in October, you have "Casablanca" in January, and then what?

Johnson: That happened in January and then as we moved forward from "Casablanca" we ran another operation "Mareth" in March, 2007, where we established another presence in COP Remagen, which was south of Ta'ameen. It actually opened up a corridor where we could push further south down in to Al Tash. So, we took the center away from the enemy, he ran southeast and northeast; then we established COP Remagen to the southeast of Ta'ameen and pushed him where our sister Battalions were positioned. We squeezed Al Qaeda from the north to the southeast, he ran southwest across the railroad tracks, if you know where the railroad tracks are south of Ta'meen; that corridor leads down to Al Tash. As we explored our options for Al Tash, we eventually executed an operation called "Kangaroo" in April, 2007. Sattar was out of town, and that is why I really

worked with Ahmed to identify their relatives and associates along the Habbaniyah Lake, we knew that they had relatives on the southwest side of Habbaniyah Lake. That allowed me to go down and execute critical reconnaissance and engagements with the local Mukhtars (local mayor or representative), which were all related to Sattar and Ahmed's family in some way.

Knarr: That's great.

Johnson: Bezea, they were all Bezea Abu Reesha. Since they were all related, that got me in the door by having Ahmed contact them. That's something we take for granted. You know, we think we have cell phones, radios, and far superior communication architectures than they do; that is totally reversed! Ahmed contacted his cousin, who contacted another cousin, who contacted the Mukhtar. The Mukhtar I eventually engaged was actually visited by one of my armor company commanders first, echeloning the importance of the engagement. The Company Commander confirmed our intelligence and informed me that, "Yes Sir, that's who you need to meet. That's who you're looking for. He's a hundred plus years old and you need to meet him." Subsequently, I arranged with the Company Commander (the CPT Ian Lauer), to establish the date and time for my visit and run security. I came in and was very direct with the Mukhtar, "This is what I want to do. I want to bring security to your area. You've seen what we've done in Ta'ameen. I have evidence. You've seen what we've been able to do in establishing Iraqi Police presence. Now we need to come south. We need to provide security for your community." I asked the Mukhtar, "Are you ok with that?" He said, "Yes, I'm ok with that, but I'm afraid." I told him, "Ok, well this is what we're going to do. Within the next month I will bring you Iraqi Police." That's the message I delivered, I just said, "I will bring you Iraqi Police." I was very deliberate, not to promise a time or place. One thing I left out about "Casablanca" that was the first joint Iraqi Police and US Army operation in Ramadi, and I have some newsletters I need to send you which detail all of our operations.

Knarr: Please. And please send me those and any briefings you might have too. [Beginning of second audio file]

Johnson: We also shared the newsletters with our wives and husbands in Schweinfurt, Germany and we communicated to them exactly what the Task Force was doing to improve the conditions within our AOR. I think for "Casablanca" we had an 850-man US Task Force, plus a 450-man Iraqi Police ERU; the Iraqi Highway Patrol that blocked the highway and facilitated this first joint operation. On operation "Kangaroo", we had additional Iraq

Police from the east side of Ramadi; once again, an 850-man US Task Force, and I think we operated with over 900 Iraqi Police of the different variants discussed earlier. Of course, I will try to find those maps for you also.

Knarr: Please do.

Johnson: The operational graphics were on them, but if you realize where central Ramadi is and you go directly south, cross the railroad tracks, you will find Al Tash. Operation Kangaroo was only a 10 kilometer offensive, and the Iraqi Police and my forces were side by side the whole way. We quickly cordoned off the city of Tash, but prior to the Iraqi assault, we ran head first into a major problem. The house we had reconned for our headquarters was occupied by an Iraqi family. If you operate in Iraq you understand that the most important thing to an Iraqi is 1- his family; and 2 - his ability to support that family. So, if we were really going to work with the local populous, understand their culture and gain their trust; we had to immerse ourselves, and we understood that we could not violate those two basic values. I also have a series of articles I'll send you on this operation, one unique thing that I did during this offensive was to contact Ahmed via a cell phone which I provided him. I asked him, "Ahmed, We're on the objective." It was me and, I can't remember the Iraqi General's name, the Police Chief.

Knarr: Was it Tariq?

Johnson: No, it wasn't Tariq, it was the Police Chief prior to Tariq. It was; you'll see it because I have it published. But, I'd say, "We're on the objective. We're standing at a house that we need to set up as a headquarters; these (I listed their names) are the occupants of this house". Ahmed requested, "If you can do anything, I would rather you not take that house." I replied, "But Ahmed, it over-watches Al Tash and is the dominate terrain, it has great fields of view from all avenues of approach. I can protect the entire community from this house by occupying the roof." Ahmed requested again, "If you have to occupy the house, do it, but I would rather you not."

Now, I'm at a cross roads. What do I do? Ahmed asked me, that if I had any alternatives, to please use those alternatives. Realizing how important this was to him, and knowing that if I go in and I take this house, the probability of Ahmed loosing face with his own family was great; because he's the one that contacted them and said, "This guy's a good guy." I left the house alone, and found / occupied an alternative location. In my opinion, that was one of the key turning points in the cooperation / collaboration between US

Forces and our Iraqi partnered forces, because not only did we communicate our commitment and partnership to that local community, we also communicated that to every Iraqi Police that had cousins in that community and watched what we had just accomplished together. They knew, “Hey we accomplished this in Ta’ameen. Now we’re 10 kilometers south of Ramadi and we just accomplished this together in Al Tash.” Which in my opinion is one of the problems we’re currently experiencing in Iraq; as we attempt to pull out so quickly?

I’m still tied to Iraq and you probably can hear it in my voice, look at what we’ve accomplished in four years, together. And don’t get me wrong, I know about the finances and economy and how everything’s tied, but look how long it took us to establish the same thing in Germany. We’re still in Germany! But we’re trying to do so much, so quickly in a country that, which in most cases, isn’t as advanced as Germany was in 1945.

We are attempting do this in a quick turn. If you read the Stars and Stripes today, it talks about the Iraqi Air Force and where they are now, and what would happen if Iran came across the border with their jets. We’ve been able to accomplish so much as a team, and that team, in principle has proven over and over and over again that its success has stabilized Iraq. Once again, the Awakening broadened from Ramadi - to al Anbar - to Iraq. [6:15]

Knarr: Let me ask you something. When I think of 14 September, I think of just simply the Awakening, but would you call that the Awakening of Ramadi or would you call it...

Johnson: That was the Awakening of Ramadi.

Knarr: Ramadi. Then, when was the Awakening of Al Anbar?

Johnson: When they saw success. I think it was actually during the transition period just before 1st Brigade, 1st AD turned over the Brigade AO responsibility to 1st Brigade, 3rd AD with Colonel Charlton. We had an event at Ahmed and Sattar’s house and this event was where we brought in other Sheikhs from all Al Anbar and we strategically communicated to them, “Look what we’ve been able to accomplish in such a short period of time in Ramadi.” We brought in additional sources from the US Government and NGOs, and afforded them the opportunity to discuss initiatives / projects they could possibly execute in a stable environment, across Al Anbar. We talked about the way ahead, as long as we could maintain security as a joint team, how we could make their lives better?

Knarr: That’s interesting.

Johnson: How could we institute governance? Not a governance of dictatorship, but a governance of the people, representative of the people, chosen by the people and whenever they decided to have an election; all we would do, would be to provide secondary security, because they had a Iraqi Police force that would provide their primary security. So we collaboratively planned security with them, and we coached and mentored them on rehearsals, which was critical to the success of the overall operation. Once again, don not make the assumption that just because it's an Iraqi force they're not professional, they don't care. Well, they do care, because the people they're protecting are their own families.

Knarr: It's interesting when you brought up that transition, there was a reconstruction conference I guess, held at Sattar's, right about the period you were talking about...

Johnson: Yes, that is the conference I'm talking about!

Knarr: That was, you think, so you would call that then the Awakening of Al Anbar?

Johnson: Right, because more Sheikhs came in from across the province. And as I said, we started off in that little room, if you ever go back there, there's a green building and it sits right behind the white marble building, that's where we started. As I said, initially there were only 22-27 Sheikhs in that room. Upon its completion, we moved to that grand hall; as you entered through the large marble doors the hall opened up to the gigantic meeting room. During that initial conference, that entire building, the whole room was full of Sheikhs; full! The transition of the movement between Al Anbar and Iraq moved even quicker, because good news spreads rapidly. When the Iraqis saw the developmental progress throughout the communities, there was no stopping the momentum enabled by our security and economic partnerships. Iraqis from surrounding areas, as well as Baghdad, began visiting; interested in seeing what we could possibly do with the glass factory, which I don't think ever came to fruition, or the wheat factory that was also on the west side of Ramadi. This was also the phase when the Provincial Reconstruction Teams (PRTs) were integrated into our operations. The PRTs were definitely a combat multiplier, which arrived at the right time, with the right skill sets and resources. Again, the Iraqis witnessed the money and resources coming in, and this was good. The PRTs helped us mentor the fledgling local Government that was standing up at that time, Mayor...

Knarr: Latif?

Johnson: Latif! Great guy! We were able to provide security in partnership with the Iraqi Police and Army, which enabled Mayor Latif to establish local governance over the city of

Ramadi. Actually, the method by which Latif was selected as mayor was unconventional by American standards, but also occurred in the little green building on Sattar and Ahmed's compound. Initially the Iraqis had another choice for Mayor of Ramadi, but after multiple screenings, other recommendations, and intense negotiations with the Iraqi Government, Latif was "selected" as the new Mayor of Ramadi. As Latif was installed as Mayor, his government building and offices were secured by US and Iraqi partnered forces. Iraqi Police provided the first layer of security, while the US Army provided the secondary layer. This is another accomplishment which communicated an opportunity for advancement to the community. Our message was, "Now you have a Mayor. What are you going to do to support him?"

My subsequent task was to form a district council from within my AOR, which would participate in a city council in order to represent the district citizens. We were initially challenged to get everyone to routinely attend our planning sessions, develop common goals, with common or mutually supporting objectives, and to agree on how we would move toward achieving those objectives. Additionally, our ability to effectively communicate this methodology to all participants in their native language was difficult at times.

Reflecting on our earlier discussion; as I stated, in the beginning the Awakening started with 22 to 27 concerned Sheikhs and leaders from throughout Ramadi. I'm convinced that initially, some of them were questionable but that wasn't my task. If you read that yearbook, its representative of my unit's extended deployment in Ramadi and the evolution we witnessed while on the ground, that is why we named it "Through the eyes of a Steel Tiger". The Awakening movement enabled my unit to view Iraq through Iraqi eyes and in my humble opinion that is why we were successful. Once you understand the environment, the culture, and what's important to that culture, then and only then can you establish acceptable and mutually supporting short term, mid-term, and long term objectives to meet a desired end state.

You also have to change your western way of thinking in some cases; not totally, we still had to maintain an offensive posture. Don't go defensive, maintain an offensive posture, but push the limits, think outside the box. And the only way you can think outside the box is if you are able to actually understand the environment, interpret culture, and identify what's important to them.

So as we demonstrated evidence of success and said, "If you want it in your community, this is what you need to do." That is the phase when the local security teams came in. A lot

of citizens did not like the name “Awakening” and that’s where the “Sons of Iraq” came from. It was a derivative of the Awakening, because they didn’t want to be associated for some reason or another with the Awakening. But, the citizens wanted security in their local neighborhoods. Also, there was a large portion of the population that couldn’t meet the basic requirements to become a Policeman (read and write). However, they could provide security locally; so what do we do? Hey, here you go, here’s an orange vest, here’s a flashlight... They were not issued any weapons, because that was not sanctioned by the Iraqi Government; but they could provide local security. Whether they went and got a weapon from somewhere else, that wasn’t the intent. The intent was to provide local security and for them to communicate back to the local Iraqi Police when they had a problem.

Knarr: The lowest common denominator of this was really security.

Johnson: Absolutely!

Knarr: The basic family, community security.

Johnson: Absolutely, and once you have security, then you have an opportunity for prosperity.

I will attempt to find you a copy of my campaign plan; my two major lines of operation (LOOs) were simplistic, Security and Governance. We did not use Stability; once security was established, we jumped straight into forming district governance, my third line of effort...

Knarr: Did you have economics?

Johnson: Yes and the PRTs really helped with the Governance and Economic LOOs. The three LOOs all had nested and mutually supporting short, mid, and long term objectives which supported our desired end state. [14:53] Our mission statement evolved over time, because once we established our partnered relationships with the Iraqis, we exploited every opportunity to achieve success.

Knarr: Of the Al Anbar Awakening.

Johnson: Absolutely! Because once gained the trust of Sattar, who was chosen by the initial group to be the face of the Awakening, we were unstoppable. He possessed the charisma and was willing to stand up and lead, even though he was not totally trusted by every local tribe. Both Sattar and Ahmed were extremely popular and well known; you know Ahmed never wore Iraqi garb until Sattar died.

Knarr: I didn’t know that.

Johnson: Oh yes! Ahmed always wore a suit. Always! As a matter of fact, I never saw Ahmed in Iraqi regalia one time before Sattar died. And from the time Sattar was killed on 13 September 2007, to the time I left that's all Ahmed wore.

Knarr: That's interesting.

Johnson: We lost 12 soldiers there and I'll never forget them, to include my PSD NCO; who was killed about 10 meters from me. Have you ever heard of Battle Donkey Island?

Knarr: Yes!

Johnson: I have the synopsis of what happened during that battle. I'll send you that.

Knarr: Please do. Battle Donkey Island, I have heard that.

Woodward: I am curious, what were the challenges that you faced over that very compressed time period? What were the things that gave you headaches during the day and made you lose sleep at night? [18:50]

Johnson: One, keeping all the Iraqi Police, not satisfied, but focused. Again, I had eight Iraqi Police stations in my area of varying capabilities. Even though all of them were competent, and could read and write, or at least exhibited evidence that they could read and write, each Police Chief had other challenges or interest. Something else they wanted to focus on.

So, I instituted what we called our Monthly Security meetings. You'll hear me reference Shamia Council; I called our district Shamia, which encompasses all communities' west of the canal in Ramadi. So, I kind of annexed Ramadi told the Police Chiefs, "You know what? All of you are from Shamia, and if I have a problem I'm coming to you guys," and we'd meet every month.

We subsequently developed a police station of the month award which was presented at the monthly meetings. Again, Iraqis are very proud; especially when they're recognized for something, so we developed a certificate which recognized hard work and excellence in security operations. The selection criteria was simple, they had to have no IED incidences or disturbances in their respective areas during the month. The first time I presented that certificate of achievement to one of the Police Chiefs, the other seven were irate and determined to enhance security operations within their area in order to be recognized the next month. The jealousy was infectious and they all exclaimed, "Well how did he get that?" and I replied, "Well, I told you guys, no IEDs for a month and I had a

surprise for you”. Ultimately, that simplistic piece of paper became a extremely effective and powerful tool. The next morning I went to the first Police station, and on the wall, for everybody to see was their certificate. The next month I presented four, followed by six. I don’t think I ever presented all eight until I left and I said, “You guys have done such a great job with progress over time this is from me.” But, once again marked improvement; something that’s beneficial to their neighborhood and also very beneficial to my Soldiers. By the time we left, in late October - early November; we turned over a very different AOR to the Marines. We were able to actually drive down the street and people would stop us and say, “Don’t go there. Last night at x hour somebody planted an IED there. This is where it’s at, that’s the wire, and I know where they live.” If they weren’t telling me or my troops as we patrolled, they were going to the Iraqi Police station in their community and telling them.

Knarr: That’s neat.

Johnson: That actually started back late June, that’s when it started. Again, when you review our successes in Iraq, even though it’s been four years, we must continue to mentor and encourage the host nation. The fledgling Iraqi Police force whether six months old or four years old; whether it’s Iraqi Police, Iraqi Army or the Iraqi Air Force it doesn’t happen overnight and it’s not sustainable without a continued commitment.

Knarr: You know I am really impressed with your TOA though. I can’t imagine, you walk in and 48 hours later you’re on an operation! That’s incredible!

Johnson: I won’t say it didn’t have its challenges and I won’t say that my troops weren’t like, “Sir, you’re crazy!” Actually I had a lot of people call me crazy the first couple of months. But “we” made it happen, and we made it happen because we were blessed by God, but we made it happen. I had some great Soldiers!

Woodward: And then when you left and the command was turned over to the Marines, did they have sort of the same...

Johnson: They listened to what we said. I’m not sure if they followed what we said when we left.

Knarr: Did you have a Battalion take your place or did you have...

Johnson: Right, we had a Battalion take over and of course they took all my entire area and then a portion of another Battalion's area. I think it was 2nd Battalion, 6th Marines. But they have a different approach.

I actually had a Marine Company attached during December, 2006, when we secured Ta'meen and were getting ready for operation "Casablanca". I tasked them to clear, and I mean clear the southeast side of Ta'meen. My Marines were very good at their mission, they were heavy handed, I call them my blunt instrument; nothing derogatory, but that's what they do best and they went out, they cleared the area and they confirmed what we needed to know. They gathered INTEL to support operation "Casablanca", and did a very good job of that. They were the precise tool that we needed at that time in that area. They did it very successfully. A guy by the name of Major Scott Houser did that for me. He was very dynamic as a Marine Officer, just talked to him recently as a matter of fact. He is extremely professional and executed that mission flawlessly, it was very successful. But, the Marines just have a different methodology and a different approach. But once again, when you're looking at sustainability they're also deployed for a much shorter period of time.

Knarr: Yeah they are. Seven months.

Johnson: You know my Task Force remained in Ramadi from October 2006 to November 2007. I'm not sure, but I think we were the longest standing Task Force in Ramadi since the beginning of the war. That longevity allowed us to establish, nurture and develop those lasting relationships over time. So, that was extremely impacting on my life.

Knarr: Thank you very much for your time and sharing your experiences.

28 June 2013

Subject: Interview with Colonel William D. Brinkley, USA, Retired, former Commander, 1st Engineer Battalion in Ramadi from August 2003 to September 2004

Colonel William D. Brinkley, USA, Retired, commanded the 1st Engineer Battalion (1 EN) in Ramadi from August 2003 to September 2004 under the 1st Brigade Combat Team (BCT) of the 1st Infantry Division (1 BCT, 1 IN DIV). 1 BCT, 1 IN DIV was initially under the command of the 82 Airborne Division (ABN DIV) until March 2004 with the 82s ABN DIV transferred authority for the control of Al Anbar Province to the 1st Marine Division (MARDIV).

As the 1st Engineers assumed their infantry mission to stabilize their assigned battle space in the restive city they quickly realized that the cultural demands of the mission required female Coalition support. As an example, the search aspect of cordon and search and searches at entry control points and traffic control points quickly turned the Iraqi populace against the Coalition as male Soldiers and Marines vetted families and mixed male/female groups.

The 1st Engineers capitalized on their abundance of female Soldiers, in particular their female medics and started using them to support Coalition operations that required them to deal with Iraqi women. The female Soldiers would remove their helmet to show they were female and then direct the Iraqi females and children to another room as the male Soldiers conducted tactical questioning and the search of male Iraqis.

As Colonel Brinkley established this program within the 1st Engineers, he coined the term "Lioness" to identify those females Soldiers that met unit standards to conduct Lioness-type operations. Brinkley established Lioness requirements and standard operating procedures to meet a need from within his own unit but was asked by other units such as 1st Battalion, 5 Field Artillery (1-5 FA) and the 1st Battalion, 16 Infantry Regiment (1-16 Inf) for Lioness support during their operations.

COL Brinkley is currently working at Training and Doctrine Command, Ft. Eustis, VA. He was telephonically interviewed on 6 December 2010 by Dr. William (Bill) Knarr and Ms. Mary Hawkins, both from IDA. The following is his account of the Lioness team development.

Dr. Bill Knarr: Please start with your background and when you went to Ramadi.

Colonel William Brinkley, USA, Retired: I was the Commander of the 1st Engineer Battalion, and I was part of the 1st Infantry Division's 1st Brigade Combat Team. We went into Ramadi in August of 2003. I know there had been some other units that had been in and

out of Ramadi, but at the time, there was only about a battalion minus there from the National Guard with, I think, a couple of troops of cavalry from the 3rd Armored Cavalry Regiment (ACR). They'd just basically been sitting on critical nodes like ammunition storage facilities. They had taken what we called Camp Junction City, which I think now is called Camp Ramadi, which was an old Iraqi military base just on the outskirts of Ramadi. And then they had taken one of Saddam's palaces in the middle of town, and that's where the infantry battalion was, which now I think is where the Marine Division Headquarters is or was. I'm not sure what's there now. We arrived in 2003 initially under the 82nd Airborne Division. They left after six months, and then we fell under the 1st Marine Division (1st MARDIV). I think we set the precedent for an Army Brigade Combat Team in Ramadi under a Marine Division.

Brinkley: Have you seen the Lioness documentary?

Knarr: We have. In fact, I pulled your name off of it and then looked you up on AKO.

Brinkley: That's good. I was still in the Army War College when that was made, so I think they interviewed me for that going on five years ago now [from date of interview]. And they started talking to me about it, oh, probably six years ago. It kind of started with my embedded reporter [Erin Solaro] who was from the Seattle Intelligencer [Seattle Post-Intelligencer]. She did a series of articles about what we were doing over there in particular to how we were integrating female Soldiers into operations.¹ I think that was the nucleus. But, in a nutshell what happened is when we got to Ramadi, we realized that a Tank Brigade Combat Team reinforced with initially one National Guard Infantry Battalion and then with one and then two Marine Battalions did not have enough infantry men to cover a city that large. And in the early days we were still fighting the Saddam Fedayeen. It was still a very anti-American province with Ramadi being the center of the Ba'ath Regime. If you do some research you'll find that Saddam Hussein really never pacified Al Anbar Province himself. And so part of his Ba'athification program is he turned it into a place where Ba'athist could go to retire, it had great universities, jobs, and all that to try to, if you will, buy them off. So we entered the maelstrom of a complete disintegration of all public services of what once was probably a fairly populous, industrialized, university city. It was also the equivalent of a state capital [as the provincial capital]. If you can imagine

¹ Erin Solaro is also the author of, *Women in the Line of Fire: What You Should Know About Women in the Military*, published in August 2006, and written from her experiences in Iraq.

every public servant in Richmond, VA just abandoning their station and opening up all the armories and the banks to everybody to loot. That's what we moved in to. [4:13]

So, initially they turned my Combat Engineer Battalion into an Infantry Task Force, and then our Artillery Battalion into an Infantry Task Force. Then we still had our day missions of shooting artillery and doing route clearance and those kinds of things. It required us to get out in the community. My Task Force's primary responsibility was to do search and attack missions, looking for enemy weapons caches, because we were trying to prevent the enemy from getting the logistics he needed to attack us with. So I was out across the battle space doing those kinds of missions.

At the time the only Combat Arms Battalion in a Brigade Combat Team that had female Soldiers in it was the Engineer Battalion. And we were sort of a special case, because of the combat exclusion clause, where females could not serve in my A, B, and C Companies, but they could serve in my Headquarters Company. So, how we initially resourced the Lioness teams was through the medics. The brigade was always short medics, so the Army would send medics to the brigade so the brigade in aggregate had the appropriate amount of medics. But they typically sent a disproportional amount of female medics. Well the only places the female medics could serve were in my battalion or in the Forward Support Battalion, which is a logistics unit. So even though the infantry, tank, and artillery battalions were critically short medics, I usually had more medics than I was authorized. And it was the same with mechanics. It was the same with the supply personnel; any of those sorts of MOS's that are open to females. If we were short aggregate, I ended up having more females than males in those, because they could serve in my unit.

So, consequently when the platoons were out on patrols, I would say 99 times out of 100 the medics that were with that platoon were female; because, I've got to have medics with the unit going out. This is still in a time period where we were still in active combat mode, so if we wanted to enter a house and use it we did. When we wanted to search for something we just went through the front door. So, what we found out is when a bunch of guys in IBA [Individual Body Armor], goggles, helmets, and weapons come blowing through your front door, it's a stressful situation for those inside the house. And I understand that. I actually did my Masters Degree thesis on why the British failed in the southern campaign in the Revolution, and it's because they did stuff like that. They ended up turning the locals into enemy versus supportive, and I understood that. So, if we were just patrolling, we tried to be more cognizant of what was going on. But you still had the situation of, "I've entered your house and your own cultural norms dictate that if

we have to search everybody for weapons, we have to search the females too.” We were reluctant to do that, because of the cultural factor. But, the enemy knew we were reluctant to do that, so they would hide stuff on the women.

So, initially we noticed that we could send one of those female medics in to search and nobody had a problem with that. Similarly we noticed that a lot of times when you enter a situation like that it gets high tension really quick. I’ll give you an example, at a traffic control point you have to get everybody out of the vehicle so you can search the vehicle. The women wouldn’t get out of the vehicle, because there were a bunch of men out there called US Soldiers, who they weren’t related to. Well, now you have a tense situation, because by the ROE [Rules of Engagement] at the time, if you didn’t get out of the vehicle we could shoot you, no questions asked. But, again, I would say 99 times out of 100, it’s a cultural miscommunication. And we didn’t have interpreters, so I’m trying to tell an Iraqi its ok for his wife to get out of the car while we search it. But his cultural norms say, “I can’t do that,” while 15 other guys are getting more and more hyped up pointing guns at him. But if we had a female medic there, all of a sudden it was calmed down. She would get right out and go right over to that female soldier and it was never an issue. And so I think we started to see that we could de-escalate a lot of situations that didn’t need to be escalated just by having the presence. [8:51]

Similarly, when we were out in the villages doing our thing, the medics would try to do a little bit of civic action. And again, remember this is early in the conflict, so we didn’t have all the high speed stuff they have now. We didn’t have interpreters. We didn’t have Civil Affairs guys. So I’d have my medics do things like minor medical stuff like treat infections, bandage things, and look in people’s ears. And again, it’s to try to do a little community outreach. I thought, since I was trying to destroy the enemy’s logistics system, I could ultimately get people to tell me information. As we started to decrease the combat capability of the Fidayeen, we started to run into more and more foreign fighters. And frankly the locals in Ramadi didn’t want the foreign fighters there any more than we did, but they had the cultural norm of Arabs fighting the infidel and they asked them for shelter and all those kind of Arabic norms that go on. So, I started making sure I had females on every one of my patrols, whether it was medics or I had a chemical platoon that was largely female. One of my best company commanders, my Headquarters Commander, was a female. And again, because of the shortage of combat power, I had to use my Headquarters Company as a Combat Support Unit. So instead of doing the typical headquarters functions of staying in the rear with the gear, she was actually out doing

missions as well. We started to see some positive benefit from this, if you will, mixing as we went out and did missions.

One night, late at night I was in the mess hall with Colonel Mike Cabrey, who commanded the FA [Field Artillery] battalion. We were talking back and forth about what we had seen on the battlefield, and I told him, "Look, this seems to be working." So it started out with, "Hey, can I borrow some of your girls?" Quote, unquote. And I'm like, "I don't think it works like that." So we brainstormed. He had a need that only I could answer, you know what I mean?

Knarr: Yes.

Brinkley: So did all the other battalions. So we started to figure out, well what can we do? And he went, "Well, why don't you let me have one female soldier?" And I go, "No, I am not sending one soldier anywhere. We'll send them in teams. And then what do we call them?" And you've seen it in a movie, we play around with Shield Maidens, and we finally came down to Lionesses. This was going to be an additional duty to whatever that soldier was normally doing. So we had to make it something that would breed some esprit de corps, because we were asking more of these young Soldiers than they were trained for. If I was trained to be a truck mechanic and now I am out in a rifle stack on a raid, you know... Now, that's not my primary MOS [Military Occupation Specialty]. And you saw some of that with Shannon Morgan in the movie. She was one of my best Lionesses. She was the best machine gunner in my battalion, and she was one of my premier mechanics. So, my view was what mission takes priority? And if it was running a logistics convoy to Baghdad to get supplies, it might be she's riding in that because we need her skills as a gunner. If I've really got some trucks that I've got to get fixed to get them back in the fight, that's probably where she is. Or, if I've got a Lionesses mission that really requires somebody with her fortitude, skills, and maturity, well then maybe that's where she goes. So, it became one of those mission sets.

I made my whole battalion go through all of the Combined Arms Training before we deployed, what little we had. We had three weeks notice to deploy. So we didn't get a lot of train up like happens now with the ARFORGEN (Army Force Generation cycle. [12:52]

So I had all of my Soldiers go through the clearing of the rooms, the react to IED, the react to contact, all those kind of drills, because normally they would only do that for what we called the line platoons. So anyway, we started to see that. And I put my Headquarters Company Commander, she's in the film, Major Pendry, the one with the horses, she

was in charge. Then Staff Sergeant Ruthig, who was the blond who you see in the movie working on a transmission?

Knarr: Yes, I know who you're talking about.

Brinkley: She became the NCOIC [Non-commissioned Officer in Charge]. And part of what I said is, "Just because you're female, doesn't mean you're a Lioness." So I gave them the responsibility to decide who would go, when they would go, and whether they would go at all. Because I was very cognizant that they were working out of their MOS. You know, if they were a cook or a medic or a truck mechanic or a bulldozer driver or whatever, they didn't come in the Army to be infantry men, and a lot of times they were out with that kind of unit doing operations. [13:59]

Pretty much everybody got screened that was female, and then it was up to the Company Commander and the Sergeant to decide when and if they would go out. And some went out and didn't do very well. And they never went out again. Some were not going out at all. I tend to limit my medical folks going out on strictly Lioness missions, because I really needed them more in the medical arena. But, the mechanics, the heavy equipment operators, and particularly when they got the dining facility set up and we didn't need our cooks anymore, we could start to use some of them. There was some controversy of, whether they were trained for the mission or not, whether we trained specifically for the Lioness before we went? Because we didn't know we were going to do that. Did we try to set up a local training program to make sure that they were schooled as well as we could in theatre? Yes. Did I make everybody in my unit go through weapons training and everything else? Yes, I did. Because one of my command philosophies was everybody fights and no one's special. And that applied to everything. It didn't really matter what your job was. If we need you to do this today, because that's what the fight demands...And it was no different from my battalion getting turned into an infantry battalion instead of a combat engineer battalion. So, you know, that was just one of those things.

Anyway, as it matured, we got sort of a feel for how it ought to go. And the Marines didn't quite do it that way, and frankly they never bought into it while we were in Ramadi. But oddly enough, they bought into it later in Fallujah. And they probably will tell everybody they came up with it now.

Knarr: That's what we're seeing. Additionally, some of the Army people are saying that.

Brinkley: I know, because, again, what comes out of Al Anbar after I would say December of 2003 or January of 2004 all goes through a Marine Corps lens.

Brinkley: So even though they kind of pooh-poohed it, particularly if you see if the movie the commander of 2/4 Marines...

Knarr: Right; Kennedy.

Brinkley: Yeah, Paul Kennedy, and his comment, "Well, you know, they're not trained." Well actually they are trained for what they were doing. You left them on the battlefield. And we could go on and on!

Knarr: That's right. I saw that and I thought, "I can't believe they left them!" [16:42]

Brinkley: And I could go on and on about 2/4 Marines inability to conduct Combined Arms Maneuver, but the bottom line is, they embraced the idea, they just couldn't execute it on the ground, because they weren't sophisticated enough.

Knarr: Well, I don't know if it was Shannon or who said, "You know in the Army we're taught to turn around. We're responsible for the person behind me."

Brinkley: That was Shannon.

Knarr: I thought to myself, "Yeah, that's right."

Brinkley: That Battalion, frankly, had a history of being chopped up into squad-sized elements and then encircled on the battlefield. There's an interesting thing, and you see them watching it in the movie where they watch a thing on the, I think it was the History Channel called "Showdown," and they mispronounced "Ramadi."

Knarr: Oh, I didn't see that.

Brinkley: Yeah, it's all about the Marines and the big fights in April. You don't hear a single word about any Soldier in that whole thing. It was done in one of those docudrama things History Channel does with these reenactments.

Knarr: I have seen a "Showdown" before. I have not seen that one specifically.

Brinkley: Well, you don't hear anything about Lionesses, and you don't hear anything about the Army. I laugh because if you talk to Marines, they will talk about Echo Company 2/4 Marines being cut up and chopped up until the Bradley's showed up. Well, there were no Bradley's that showed up, they were actually my C Company and M113s, but the Marines didn't know the difference between a Bradley and a 113. But, you'll never hear about the Army. They said they were cut off until reinforcements showed up. Well, that actually was my Task Force, but in that fighting that that documentary claims to show,

there were four Army Battalions and one Marine Battalion. And that fight was led by an Army Colonel named Buck Conner [1st BCT Commander, 1st Infantry Division].

Knarr: Buck Conner? I've heard of him.

Brinkley: Yeah, he's retired now, too. But, you don't hear a word about us. So you see my Soldiers watching that when they had their Lioness reunion. They know they were there. They know exactly where they were on the battlefield, but there was not a mention of them. So, you've got that going kind of against the Army. I even read the Army's official history of the first part of the war, and it hardly says anything about Ramadi, let alone the Lionesses. So, I was beating up our historian. "Where's the Al Anbar part of this?"

You know, so as the guy that fought in first Fallujah and left a week before second Fallujah, I know what was going on between Fallujah and Hadithah, because I was right smack in the middle of it. But you don't hear anything about our brigade. And we were relieved in place by 2nd Brigade, 2nd Infantry Division which deployed from Korea to Ramadi.

Knarr: Yeah; Patton's Brigade.

Brinkley: Yeah, Patton's Brigade; Absolutely! You never hear about them either, because they fell under the 2nd Marine Division. And those guys are even wearing 2nd Marine Division combat patches.

Knarr: That's right. In fact, who is wearing 1st MARDIV Guadalcanal patch from the second battle for Fallujah?

Brinkley: Well, I have an official notification from the Army G1 that everybody in our brigade got, and a formal request from the Commandant of the Marine to allow our Brigade to wear the Guadalcanal patch as a combat patch. Now my brigade all universally decided we were going to wear our Big Red One patches. But, I know the 2nd Division guys, a lot of them wore the Guadalcanal patch. But they have a history with the Marines, because the 2nd Division was commanded by a Marine in World War I, and the two Marine Regiments that were part of the division wore the Indian Head patch as a combat patch.

Knarr: I recall that. [20:57]

Brinkley: So, anyway, that's kind of what happened. Mike Cabrey's battalion started to use Lioness Teams. I wanted to make sure if we were going to task organize with this capability in a brigade order, it wasn't like, you know, 1st Engineer give three girls to 1-5 FA or 1-16 Inf. So, the Lioness Teams became a team concept and you usually got one team. I think the largest number that we ever sent was four teams, which would have been eight Sol-

diers. And really the design was to allow the Lioness to effectively segregate woman and children from the men. And so you kind of de-conflicted any sort of escalating tension on the Iraqi male's view point. It also allowed us to search and question the females separately. It was amazing what women will tell each other, even if one of them is wearing IBA and has an M-16. We found out real quick that they didn't want the weapons caches around their villages either. And so we started that sort of engagement with them then.

I actually had a conversation with a sheikh one day about why they were fighting us. I said, "You guys are losing, because you guys step out in the street with a weapon, and we're going to fight you. You shoot us, we're going to fight back." And it was funny, because the Awakening was what this ended up being. I said, "You guys are business men. So are we. But we have short memories. If you behave right now for 18 months, just behave. Don't allow anybody to misbehave in your tribal area. We'll have a victory party, and we'll go home. We will shower you with money. And that's good for business. But as long as you keep supporting those guys that keep killing us, then we're going to kill all of you. And ultimately you, as a businessman will see that they aren't offering you the better deal. We are." And he agreed. He said, "I know, but I'm Arab, and they're Arabs. And you're an invader. And you're an infidel." He went on and on. I got it. So, that's why I said, "One day, they're going to wake up and all these Al Qaeda guys are going to be lined up dead in the street, and they're going to wonder what happened." And that's what happened in Ramadi. But I think Ramadi looked like Dresden by the time that happened.

Knarr: I've been there a couple of times and you're right.

Brinkley: It was pretty beat up. But, I'll give you some things that we did from an Awakening standpoint.

Knarr: Okay.

Brinkley: Beside the Lionesses, which are close to my heart, when we first got to Ramadi, most of the people had no power unless they had a generator. There was no water really flowing anywhere. There was no functional police force. None of the schools were open. There was no fire department at all. There were no traffic signals. The markets were empty. There was nothing to buy and there was no one there to buy it. There was very little traffic at all. When we left in August/September I guess of 2004, you had a functioning, but corrupt police department, but at least there were police. The first guys to come back to work were the traffic cops. They just put on their uniforms and came back out and started directing traffic. Now, I have two theories on that. One is, the city was a

mess without them and the traffic flowed much better in the city with them. But, I also think they were also look-outs for the enemy.

Knarr: Wow.

Brinkley: That's sort of Brinkley's view. It's similar to anytime we stood something up out there, it was immediately infiltrated by the enemy. When we started training the Iraqi Civil Defense Force in Fallujah, an entire brigade of them flipped sides. [24:50]

So in general you went from nothing to something. So, the traffic guys just came back to work. Then we started standing up the police department. Then we built the Al Anbar Police Academy there at Camp Junction City to start training them. The Marines brought in contractors; the same sort of guys that were in the Police Task Force in Bosnia and Kosovo. The same group of guys came in to start teaching them how to be a professional police department in Ramadi. I know one of the guys that was in there was a guy that was on the International Police Task Force that I knew from the Balkans when I was a Major. And so they came in and started teaching.

We set up a sort of a quasi Military Academy there to start teaching and standing up the Iraqi Defense Force, which ultimately became the Iraqi Army. By the time I left there, not only had the schools been cleaned up, painted, and fixed, the kids were going back to school with books and in uniform. Whereas no one was going to school when we started. Al Anbar University had started back up. It was no longer a defensive position for an artillery battery, and they were having classes. The market was open and fully functioning again. We started to get people access to clean water and then we found out things like Saddam cut the water off. There was a beautiful water treatment plant in the middle of Ramadi that only treated the water for Saddam's palace. Those kinds of things started to happen. Buildings started to get repaired from battle damage. Like I said, the kids were back in school. One of the big things we did was get the fire department running again and paying people to pick up the garbage. Those kinds of things started to happen in Ramadi under the 1st Brigade Combat Team, because we owned Ramadi. Now the Marine Division Headquarters was there in Ramadi, but the Marines were actually set up with the Marine Air Wing in Al Asad, a regiment in Hadithah and a regiment in Fallujah. And the Army Brigade Combat Team was in Ramadi with one Task Force in Habbaniyah, which was half way between Ramadi and Fallujah. And then they had a Marine Battalion in Ramadi to reinforce the Army Brigade Combat Team there, and it was based at Hurricane Point. And it's called Hurricane Point, because the first Battalion in there was

the 1st Battalion of the 124th Infantry Regiment (1-124 Inf) Florida Army National Guard, better known as the Hurricane Battalion.

Knarr: I didn't know that.

Brinkley: That's where it got its name.

It's just like Camp Blue Diamond was originally camp something else when the 82nd was there. And it's Blue Diamond because that was the call sign of the 1st Marine Division. You know the first Marine Division wanted to call everything by the local city name, so it didn't look like we were occupying, which is why Ramadi is called Ramadi now. But we always called it Camp Junction City, because that has a significance with the 1st Infantry Division. So, yeah, that's how Hurricane Point got its name, from the Hurricane Battalion.

Interestingly enough, the Battalion Commander of that National Guard unit was the Miami Dade County Florida SWAT Commander. And a lot of the people in his unit were Miami Dade Policemen. So he brought police science, and he was instrumental in helping set up the Police Academy and trying to get that going, because he was a policeman. So that was where it started. I have to say, it wasn't great when we left in 2004. We had the heavy fighting in April and that just continued until we left. I mean the last thing I did in combat was call in an airstrike in Fallujah as I was trying to fight my way back out of it. Interestingly, my first fight in Iraq was in Fallujah in 2003 trying to get to Ramadi.

There were still some significant fighting happening. I think in the whole 13 or 14 months I was there, we only had one day where somebody in the BCT [Brigade Combat Team] didn't have contact with the enemy. So, pretty much, we had contact, significant contact, every single day. Each of the battalions had similar losses. We all had somewhere between 10 and 15 killed and 60 or 70 wounded, every battalion in the Brigade except for the Forward Support Battalion.

So, you know, it wasn't by any means easy. But we took something that was absolute chaos on a medieval level and moved it forward at least to the 17th century. I think by the time we left we sort of had pockets of resistance. Sofia was still bad. Ta'amin was sort of bad. Certain parts of down town like what we called the Agricultural Center, but it's really a mosque. That area south of the soccer stadium was always sort of enemy territory. We'd go in there with our operations, but we just didn't have enough people at the time to garrison the whole town. So we garrisoned Hurricane Point, and we garrisoned the combat outpost, which is just outside of town, right on the corner where the Sofia peninsula is.

Knarr: Oh, you're talking about what turned into Corregidor later?

Brinkley: Well, I don't know we just called it the combat outpost. It was before it had a name.

I think it has a name now. And that's where they put in the first substantial amount of Iraqis when they went in. That's really all we had. And then we actually out-posted from Ramadi to Habbaniyah, like every half mile was an outpost to watch Highway 10, because it had so many IEDs on it. You could just hardly travel it. I mean it wasn't if, it was when you were going to get attacked or IED'd. The vast majority of our casualties took place on Route 10 between Ramadi and Fallujah. So that was the start of sort of what came in with the Surge of putting small units out in the population. [32:28]

That started on Route 10 in OIF 2 between Ramadi and Habbaniyah. And they were manned by a combination of Field Artillery, Mechanized Infantry, Marine Infantry and 1-34 Armor, which was our Armor Task Force that was in Habbaniyah. And it's things I remember back on like they initially weren't going to let us take any artillery, because it was supposed to be a peace keeping mission, and we weren't going to need it. And we took one battery of the battalion, which is part of why they could turn the FA battalion into an Infantry Unit. Well those guns fired their tubes off. The Tank Battalion basically went in dismounted with just a few tanks. The Mechanized Infantry Battalion basically went in HMMWV mounted, not Bradley mounted. The only battalion that went in with its entire TO&E [Table of Organization and Equipment] kit was mine. I became the Infantry Battalion, the mobile infantry, because I could move around in armored vehicles with a fair amount of combat power versus hummers. And you know the hummers we went in with weren't armored, they were just the standard every day hummer. We armored them with found-on-the-battlefield steel initially.

So, a lot of those things that you saw in the Awakening started with us. I'll tell you the biggest lesson learned is not being able to talk to the people. You know, the little hand out [card] we got that said *keff* is "stop" and it was all sort of oriented on, "do this or I'll kill you," phraseology. But we didn't know how to pronounce it right. I didn't know anything about dialects. I didn't know anything about tribes. I didn't even know there were tribes until I got on the ground there.

Knarr: That's amazing.

Brinkley: And you know the little bit of lessons learned we got with guys that had just come back was all about Saddam Fedayeen and the remnants of the Iraqi Army. It was nothing about hearts and minds. So, we had that sort of mentality. I know when the Marines

came back in they thought they were going to soft hats and wave at everybody and they'd be your best friend. It just got bloody for them. [34:35] It took some time. I think they finally had to get it beat out of them before they came around. I don't know if MacFarland was the third or fourth BCT in there?

From my understanding, the 2nd ID had similar levels of contact and similar levels of casualties that we did, and so I think it just took time to beat the support-for-the-insurgency out of them. And then ultimately much like my conversation with the sheikh, one day they flipped and that's the day that everybody found the Al Qaeda guys dead by the government palace there. It just took enough of them having their heads cut off and their tribal traditions being stomped all over by the Al Qaeda guys that they said, "I've had enough." And that's where the one sheikh, who was I think the third son of the original sheikh...originally the sheikh of sheikhs was in Ramadi when we were there. And he was known as the American Sheikh, because he was an American citizen who got run out of Ramadi about 25 years before we got there by Saddam Hussein. He set up his base in Los Angeles and still ran his empire in Iraq from L.A.

And so we came in and Saddam fell, and he came home. He went back to his compound and set up business. He was the sheikh in charge of all the tribal sheikhs in and around the Ramadi area. I don't know if he's still there or not. I think he might have been actually killed.

Knarr: So you and Mike Cabrey coined the Lioness?

Brinkley: Yes, over dinner one night at midnight chow at newly opened Camp Ramadi, Camp Junction City, KBR [Kellogg, Brown and Root] DFAC [Dining Facility].

Knarr: Let me ask you, I've gone to CALL [Center for Army Lessons Learned] and pulled some stuff up. Did they have any transcripts from you or your unit or from anyone else in the Lioness?

Brinkley: Well they should have... I don't know what happens to your battle logs when you turn them in. I don't know if they're in CALL. And we never saw CALL. That was the interesting thing. The whole time it was so dangerous journalists would not come out to Ramadi unless they were embedded. So all the USO and all that stuff never came out there to include people like CALL and the Corps of Engineers, any of those kind of groups that were supposed to be there helping us rebuild the country, you know. We couldn't even get ammo and fuel on a regular basis.

Knarr: You came up with the Lioness concept because you needed them.

Brinkley: Yes, absolutely.

Knarr: To help you do the patrolling and the TCP [Traffic Control Point] type mission that you're required to do as an infantry unit.

Brinkley: Yes, and it was just like you said, serendipitous, because of the organization of my unit. I had more female Soldiers in it. So in order to support my units when they were out doing their missions, the medics and so forth in many cases were female. We started to see the positive impact of having a female out there when you're interacting with the locals, particularly with their taboos of their women and children talking to somebody that's out of the family that's male.

Knarr: Well then Mike Cabrey, I guess was the second battalion to start using them.

Brinkley: Yeah, he started it. And then Tom Hollis [Lieutenant Colonel, Commander] his 1-16 Infantry used Lioness a little bit, but not much. Then Paul Kennedy's Battalion, 2/4 Marines used them a bit. I would say misused them more than used them.

Knarr: Now when did he finally get some? When did you start this?

Brinkley: We probably started this right about the time we were transitioning from the 82nd to the [40:57] 1st Marine Division. Maybe a little sooner than that. I mean, I was doing it from jump street. And probably Mike Cabrey started using them next. Then I would say Kennedy probably started using them in the March timeframe maybe. I'm trying to remember exactly when they came in, but I know he had them in the heavy fighting in April.

Kennedy because we had used Lioness with the Hurricane Battalion, when they did their TOA with 2/4 Marines, that was a topic of conversation, but whereas the National Guardsmen of the Hurricane Battalion were all for it. I think we had to get through a little bit of that machismo thing with Marines, because they don't have a lot of females in their formation. I don't think there's any females in a Marine Regiment. I think you you've got to get up to Air Group and Logistics group.

Knarr: So you probably used them around, I'm going to say around December and January?

Brinkley: No, I think we were using them probably full blown by the end of September, beginning of October.

Knarr: Ok.

Brinkley: Cabrey and I, because we probably got on the ground good.

Knarr: Well, when did you get there?

Brinkley: We started flowing in in August. I think we were full up in September. We were doing missions.

Knarr: So you were using them for six months before the Marines even started using them?

Brinkley: I would say between four and six. I don't have all my notes in front of me so. We had good experience at Army level and the BCT using them. We had formalized the process. You know, if you see a mission where you're going to need Lioness support, how do you ask for it. What does it mean? What are they used for? What are they not used for? You know, those kinds of things that already had been established within the BCT. So, we had that working pretty well. Like I said, 1-16 Infantry did use them some, but not a lot. 1-124 Infantry, if I remember their nomenclature right, they used a lot, like two or three teams a week for operations. The Marines, I know they were using them in April, because basically the day after I lost five guys, the day the Black Water thing happened and then it was Katy bar the door like the next day. I know that because I know that we were supporting them then when they were trying to get into Sofia and trying to get in around town.

The base idea, which is why it was irritating to find out that those young Soldiers were left on the battle field by Marines is that, you know, they were going to enter a building, usually the Lionesses were the last to. So the guys would enter the building and clear it if it was that kind of clearance...if it wasn't like a knock and socialize kind of thing. They would enter the building. Once it was clear then the Lionesses would come in as they were segregating the citizens that were inside the structure. And so they would put all the children and the women with the Lionesses and they would start questioning them. But again, if we had had just a little bit more interpreter support it would have been a lot easier. Because I think at the end I only had two interpreters in the whole battalion.

Knarr: In the battalion; that's terrible.

Brinkley: And I had one of them on the gate to deal with all the contractors and stuff going out. That means there's only one, and I would put out anywhere from 10 to 15 patrols a day, so where's that one guy go? And none of us spoke Arabic. I mean I had one 1st Sergeant that was native Arabic speaker, but he left within the first month we were there to go to become a Sergeant Major himself. I lost that guy. We only had one or really two interpreters in a 900 soldier task force. In theory we should have had somebody that could

speaking Arabic at every TCP. You know in a perfect world every platoon would have one. You know some of the *shuras* you see now where they sit down and talk with the elders?

Knarr: Yeah.

Brinkley: There was no way that we could do that. We'd just look at each other. They spoke English a little better than certainly we spoke Arabic. That's probably my biggest lesson learned. I mean early in a war you don't know what you don't know, but interpreters would have certainly been helpful.

Knarr: That's incredible.

Brinkley: I mean even watching *Saving Private Ryan* last night. What's he looking for? A guy who can speak German and French. Well, ok, it's still applies! [46:19]

Hawkins: After that time period when the Lionesses were being used by you and the Marines did they move to any other areas in Iraq other than Anbar?

Brinkley: Not mine. No, my Soldiers stayed within our Brigade Combat Team footprint.

Hawkins: How about just the idea of using the Lionesses?

Brinkley: I have no idea. Maybe. I know it was on CNN and it was some other places. I know that I got asked if we were using females forward of the Regimental rear line. I didn't really even know what that meant, but... I said, "Sir, they're being utilized based on their unit of assignment like any other soldier in the unit is," because that's what we were doing. I really didn't know what the Regimental rear was, because there really wasn't a rear. So, no, none of my Soldiers went anywhere else. They didn't even get to Fallujah to be honest with you. We very rarely had enough stuff to send anywhere else. So, I don't know.

Hawkins: Ok.

Brinkley: Maybe it self-generated other places or maybe some of the articles in the press floated around and people thought that was a good idea and adopted it. I think the Marines and maybe in OIF 4 or 5 came up with a formal Lioness Program of some sort, because I know they had them all in one truck and they got blown up in Fallujah one day.

Knarr: Wow, I didn't know that.

Brinkley: Which is not what I would have done. And I think that was probably OIF 3 or 4 when that happened. They had all the Lionesses, you know, six or eight of them in one truck, and they got blown up. And so they lost all their Lionesses. I don't know if they lost focus on the program or what.

[Note: Discussion on various Lioness team-members]

Brinkley: I know Shannon Morgan had a host of issues once she got out of the Army, unfortunately, that she starting to deal with. But, she's becoming a big proponent of females going to the VA [Veteran's Association] and getting help. I know I talked to some VA lawyer who was trying to figure out how to codify Team Lioness operations so they could track females that came in with PTSD claims or other type...

Hawkins: I was going to ask you about that, because they don't have the combat on their cards or their information...

Brinkley: But they should have Combat Action Badges.

Knarr: That's right, I've seen them with Combat Action Badges.

Hawkins: Ok.

Brinkley: The problem we had is that was, for example, Kate Pendry and Stacey Breslow had Combat Action Badges, because we were in before that was an award. So, at some point several years later they decided everybody that meets the criteria is authorized those. Then you had to scramble back and get it. So for probably six months I did statements for everybody under the sun in the unit. But you had to back it up with unit diary data and sworn statements and everything else. Now it's perfunctory. It's like a Combat Infantry Badge. If you're there it's just processed while you're in the unit. So, I probably had a ton, as I told this VA lawyer, a ton of female Soldiers and maybe male Soldiers as well. And I would go out on a limb and tell you that probably 90% of my battalion task force is probably authorized a Combat Action Badge. But when you come back and you blow the unit up, you know, "Where did they all go?" So, did Shannon Morgan ever get one? I don't know. And I've been trying to go retroactive on stuff like that. I think the people that were still on active duty might or might not have gotten taken care of if they knew to ask, but if they didn't then they wouldn't. So, I think it's probably better now than it was then, but I don't know how you go back and figure out who did what to whom at this stage unless they come forward themselves and say, "I should have gotten this." And then you can go back to them and say, "Yes you should have." [52:05]

Knarr: Yeah, that's right. This has really been interesting. I really appreciate you taking the time to talk to us.

Brinkley: My pleasure. I always like talking up the exploits of my Soldiers. And as I said to the film makers, "I am not going to talk to you about the female exclusion policy, be-

cause that's a policy and you need to talk to the government about that. But I'll talk to you about women in battle all day long, because I have first-hand experience with that."

I will tell you, those young ladies, I'm proud as I can be of them. They absolutely gave everything they were asked of and they did a great job at something very different and new and scary. And they were very professional with it. I have the utmost admiration for them.

Knarr: That's incredible. I'm probably going to have this typed out, and I'll send it to you for your review. Make whatever changes you want, we just want it to be accurate and for you to be comfortable with it.

Brinkley: Ok. Well, I'll be glad to. I mean again, you know it's getting a little way back in time, so with a little prep, I can go in the attic and find all my notes somewhere.

Knarr: That would be great.

Brinkley: I have a daughter that's in ROTC. She's wants to be an Army Officer. She was influenced by all of these Lionesses. You know, it's part of why she picked the military as a career. My wife will tell you, I'm not a big feminist, but I'm all for if you can do the job, you ought to be able to do the job. And I certainly learned from combat that like any other soldier, if you're cared for and led right and you've given clear mission and guidance, you'll be amazed at what they'll do.

Knarr: I agree.

Brinkley: All things considered, I had very little discipline issues. So, I'm very proud of those young soldiers both male and female, what they accomplished; but the Lionesses get all the lime light.

16 January 2013

Subject: Interview with Colonel Richard Cabrey, former Commander, 1st Battalion, 5th Field Artillery, in Ramadi in September 2003 to September 2004

Colonel Richard Cabrey commanded 1st Battalion, 5 Field Artillery (1-5 FA), as part of the 1st Brigade, 1st Infantry Division in Ramadi from September 2003 to September 2004.

In mid-November of 2003, then-Lieutenant Colonel Richard Cabrey met with LTC Dave Brinkley, Commander, 1st Engineer Battalion (1st EN), to discuss the sensitivities of missions that involved Iraqi women and children, and in particular search-type operations. Those discussions were the catalyst for developing the Lioness teams – at least two females Soldiers that met unit standards to conduct Lioness operations.

Soon after Lioness Teams were successfully used for traffic control point and entry control point searches, Cabrey began assigning them to cordon and knock and kill or capture missions. Cabrey estimates that Lioness Teams assisted his unit in 85 to 95 percent of their missions, which totaled approximately 250 missions in all.

Per COL Cabrey, the value added of Lioness Teams was tremendous, he received positive feedback from Iraqis who said they appreciated the Coalitions' effort to adapt to the Iraqis cultural norms. In addition to a more positive approach in dealing with the population, the Lioness Team members often fulfilled critical intelligence requirements through their searches and engagements with Iraqi women.

COL Cabrey is currently stationed at Fort Sill, Oklahoma. He was telephonically interviewed on 7 December 2010 by Dr. William (Bill) Knarr and Ms. Mary Hawkins, both of IDA. The following is his account of the Lioness Team development during his command of 1/5 FA in Iraq.

Colonel Richard Cabrey: We were in the process of executing our last kind of CPX [Command Post Exercise] before heading out to NTC [National Training Center] for a full spectrum, heavy metal, force on force exercise. It was late August, I think, so I had been in command about six and a half weeks. In late August we were finishing the CPX, and we basically got notified on a Friday that we were going to rail load to Beaumont, Texas. So we had a weekend to get all of our equipment, property, basically split up, put our guns into our vehicles to get ready to ship out. Then we really had about three weeks to get the main body folks ready to go. So we did some very rudimentary training. They brought in a team from the Joint Readiness Training Center to give us some classes on

dismounted and mounted patrolling. At that time, we still kind of thought that what we were going to do was provide fires. We rail loaded six Paladins, six howitzers, and all of our ammunition vehicles. We figured that we'd probably get counter-fire mission and some base defense type mission for our battalion. We got to Kuwait. We did the weapons calibrations and all the test firing of our equipment. We drew all our ammunition, and by that time, the brigade had sent an advanced party up to Ramadi. The Brigade Commander called me. He said, "We're going to need you to take over battle space." So, about five days before we occupied Ramadi is when we found out we were going to be battle space owners. We received a chunk of Ramadi that was called Ta'meem and Five Kilo. These were the terms we used for that area in Ramadi. Everybody who's been there understands that Ta'meem and Five Kilo are just right across the canal from the main part of Ramadi.

Knarr: Yeah, I know where it's at.

Cabrey: And so, when we got there, we actually had kind of a relief in place mission with two units. One was 2-5 FA who'd been occupying out by the Al Anbar University. Then 3rd Squad and 3rd ACR had responsibility for some of the area as well. Their boundaries were a little bit different than what our Brigade had fallen in on. So we kind of RIP'd [Relief in Place] with two different units in that process. So, mid-September, we were in charge of the Ta'meem and Five Kilo area of Ramadi. Plus we had the Hot Platoon Mission, and we had the Base Defense Mission for Camp Ramadi or Camp Junction City as we called it back then.

Knarr: Where were your guns? Where the paladins? Where'd you have those? Right at Camp Ramadi?

Cabrey: We kept three guns at Camp Ramadi, and we put three guns down in Habbaniyah across from Taqaddum Airfield in order to achieve some type of fire support throughout the entire brigade's battle space. And so we literally could range from Fallujah...in fact, we supported the Marines with a lot of missions into Fallujah from Habbaniyah because of the range of the paladin. We could actually get the guns from Habbaniyah to overlap with the guns from Ramadi in that stretch of MSR [Main Supply Route] that ran between the two of them. So, we had pretty good coverage, but really only two guns manned at both locations at any one time, and a 24 hour coverage primarily for the counter-fire fight. Fallujah I is a good example where we kind of almost went in to Fallujah, but didn't go all the way. That was one of the options when we actually pulled a couple of the guns out of

their hot platoon mission, accepted risk for the counter-fire fight, and moved guns forward with the maneuver forces so we could position. There were also a couple other missions that we did especially with the Marines that we maneuvered our artillery with the maneuver forces outside of the FOB and had them into the maneuver fight. But most of the time, two guns were remaining hot at all times at both those camps. [04:41]

Knarr: During your pre-deployment training, did you know you were going to go into Ramadi?

Cabrey: We knew we were going to be in Anbar. That was the one thing we did know. And that was because we found out we were going to be tasked organized with the 82nd Airborne Division. We just kind of put two and two together and saw that Anbar Province was the area. Where in Anbar we were going to be, we weren't really sure before we deployed. So, at least from my perspective, we had no awareness of Ramadi and specifically the Ta'meem/Five Kilo area. We didn't really have any kind of a cultural prep. We knew that there were Sunni and Shia in Iraq. We knew it was predominantly Sunni where we were going, but that was about it.

Knarr: When you got into Kuwait, you talked about the brigade. What brigade were you part of?

Cabrey: 1st Brigade, 1st ID [Infantry Division].

Knarr: Ok, good. And of course then 1st BCT moved into Ramadi?

Cabrey: Yes.

Knarr: Did they move into Camp Junction then?

Cabrey: Camp Junction City, and then we called it Camp Manhattan. Actually it was Habbaniyah down by TQ Airfield. So we had Support Battalion at Taquddum Airfield, and 1-34 Armor was occupying down in Habbaniyah. I attached a Platoon of Paladins to them. Then we had the engineers and 1st Battalion, 16th Infantry [1-16 Inf]. At first we had a battalion from the Florida National Guard working with us in Ramadi. And then they were replaced, eventually, by 2nd Battalion, 4th Marine Regiment [2/4 Marines]. They were the other Marine Battalion that became attached to the brigade. And also at Camp Ramadi, we had the 1st Engineer Battalion.

Knarr: Ok. Now, 2/4 Marines took Hurricane Battalion's place?

Cabrey: Correct, out on Hurricane Point there, right.

Knarr: Right. Ok, now I'm situationally aware, I think. How many troops did you have? People talk about force structure, and you had a more complicated situation. I mean, it wasn't just troops, you were also doing a counter-fire mission.

Cabrey: And the base defense.

Knarr: And a base defense, so how many troops did you have?

Cabrey: I had my five batteries, and I'll break it down: Alpha, Bravo, and Delta Battery, because we had Delta Battery, 1st Battalion, 5th FA [1-5 FA], Hamilton's own. Then I had the Service Battery, Headquarters Battery, and I wouldn't say at my disposal, but while we were at Fort Riley and for garrison operations, administratively I had the Brigade Reconnaissance Troop. Now, it was very clear from the brigade that the Brigade Reconnaissance Troop was the Brigade Commander's. But their supply and everything came from me. And there were long periods of time during the deployment, a couple months at a time, that they actually were attached to me for operations in the Ta'meem/Five Kilo area. But they were the brigade's assets, so I can't really count them as my troops.

But I probably had about 450 to 500, because I had to strip out all the fire supporters. At that time, the Fisters [Fire Support Teams] belonged to the Artillery Battalion. So they were a part of HHB [Headquarters Battery], but they were all assigned out to their Infantry and Armor Battalions. So I did not have the 13 Foxes as fire supporters attached to me or working with me.

So, as we started looking at troop to task, really what I had was...Service Battery was fully engaged, especially when we got there. We didn't have KBR so the cooks were fully engaged and the mechanics were fully engaged. Once we'd established the communications on the camp, all the TOC [Tactical Operations Center] personnel of HHB were fully engaged. Of course, they had the medics that were established for us. Once we had the com-metrological kind of stuff established there, they were another additional force pool of about 30 soldiers that I could pull in for other missions. Base defense was really the primary one. And so, I knew I didn't have to mass a battalion's worth of fires, so my battalion FDC [Fire Direction Center] became the base defense command post. I figured I had guys that knew how to talk on radios, guys who were familiar with maps, and somebody who was already integrated into my TOC – the Battalion FDC. That gave me an officer, Senior NCO [Non-Commissioned Officer], and a couple soldiers that I could assign to that mission in terms of controlling trip reports, trip tickets coming in out

of the TOC, monitoring all the OPs that we established around there, and then controlling a Base Defense/Quick Reaction Force of about four gun trucks total.

Then, what that left me was basically a little bit over a battery sized element or roughly about 115 people to put at the maneuver mission, the "Infantry" mission if you will for the Ta'meem and Five Kilo area. And in that area, we did have one major police station that we dealt with. And then we eventually established what is called a CDC, the Civil Defense Corps. We stood that up early on in the whole process, so we kind of partnered with our own CDC guys and the police. But it was basically about 120/130 people at any one time that were with the maneuver mission. The way we ran this is for four months. Initially my Bravo battery had the maneuver mission. Then I flip flopped between the counter-fire and base defense, two months each for the other two firing batteries in terms of that was their mission to run it.

So at the four month mark, we did a complete RIP/TOA [Relief in Place/ Transition of Authority] internally. My Delta battery took over the maneuver mission, and Alpha and Bravo continued to flip flop with base defense and counter-fire. At the eighth month mark, we flipped again. Alpha Battery took over maneuver, and Bravo and Delta did the base defense and counter-fire. And my thought was during the counter-fire and base defense were missions complacency could set in very quickly. So my mode was to rotate that every two months, and then maintain section certification gun capability; every three months we ran a practice live fire. We'd cut out a chunk of terrain outside of Ramadi. We got some observers, cleared some land, and brought some [hunks] out there. We GPS'd the coordinates in, and then allowed our section to execute live fire missions that we hadn't been doing as part of counter-fire. So we kind of rotated people through that cycle. [11:48]

Knarr: Wow! Well you answered the question on what I will call discretionary forces. And you said about 150?

Cabrey: About 150. Service battery became the element that did a lot of the hauling of all of our class supply between TQ Airfield out where Support Battalion was and Camp Junction City or Camp Ramadi as it became known. So every other day we were sending major convoys out with the Service Battery. They also did a lot of the runs to Baghdad to get PX [Post Exchange], KBR, CONEXes [Container Express] and all that stuff that ran the Brigade. So the Service Battery was a big work force. They were just folks that could not get out there on the maneuver mission, because they were so busy as it was.

And there was a part of the Ammunition Platoon, about 12 of those soldiers, who were selected as the PSD [Personal Security Detachment] for the Brigade Commander, so I lost that element out of them to begin with.

Knarr: Now when did you come into the Lioness? I guess you had talked to Colonel Brinkley?

Cabrey: Dave Brinkley and I had gone to SAMS [School of Advanced Military Studies] with each other back in '96/'97 time frame...I guess '97/'98 we sat next to each other in SAMS at Leavenworth. So we'd known each other for a few years. He was my battle buddy in Iraq. Between my Sergeant Major and Dave Brinkley, they were the two that I was closest with. But, I guess it was probably about mid-November, so we'd been there for about a month and a half, almost two months. I was talking to him about the maneuver mission we had, running traffic control points, and doing these cordon and searches. I said, "One of the things that really gets me nervous is we go into a lot of these places, and there are women and children. Or you go to a TCP [Traffic Control Point] and there are women and children in the cars you stop, and the anxiety levels get amped up... women and kids screaming." I said, "The worse thing I could imagine is a soldier who gets anxious and in the heat of a moment of confusion somebody shoots when they shouldn't." And I said, "It could be that the woman or the child just has a natural reaction to what we're doing, which causes a soldier to make a wrong decision."

So I was telling him it would be great if we had some women that could come out on these TCPs with us at a minimum as well as some of the kill or capture, you know, high value targets. We thought what we had was a lot of suspected foreign fighter facilitators, not so much the really hard core guys that were aggressing against us, but a lot of facilitation going on in the Ta'meem/Five Kilo area. So we had quite a few targets like that, and a lot of them ended up being families. And so I was telling Dave that I think it would be a great combat multiplier to be able to have somebody that could help me diffuse the anxiety level. He mentioned that he had some female soldiers, mostly in his HHC. Mechanics, heavy equipment construction operators, and a lot of the initial hard work of building our berms and all that stuff in Ramadi had been done. He said they were all qualified on their weapons and all good soldiers.

So we took that as an opportunity and we kind of hashed it around. I think Dave put the requirement of a minimum of two. You're not going to have one single individual female

go out. Let's have her go out with a battle buddy...a team of them. That kind of coined the term Lioness Teams. I think Dave came up with that...his Lioness Teams.

And so we started taking them out on TCP missions with us, Traffic Control Points. So what we did is we were very deliberate in our planning and rehearsing aspect. We would have them come to the orders brief. We would have them go to the ROC [rehearsal of concept] drill and then a full dress rehearsal. We'd find some type of terrain on the camp that simulated where we were going to be so that everybody could get a feel for how much space and distance was between everybody, what their roles were, and who was going to report to whom. We started doing that with TCP practicing and then that eventually evolved into the missions that we were doing out in the town, whether it was going to be a knock and greet, a full blown cordon search type operation, or I'll just call them engagement operations. We'd go out to major groups of apartment buildings and hand out information or flyers on governance or whatever it might be that we were trying to educate the Iraqi people on...the development of governance in their country and what the CPA [Coalition Provisional Authority] was going to do.

So, I'd take the women soldiers out with us on those things, especially because they could engage with women and children a lot when the men weren't even around the houses. So, they started just embedding with us all the time for missions. We'd put a request into Dave. I'd give them the heads up, "Hey, next Tuesday we're going to be doing X. We'd like to have two Lioness Teams." They would come down to us for all the orders briefing and all the rehearsals. Pretty soon it became pretty regular. We had a group of about eight to ten female soldiers of all ranks, from PFC [Private First Class] to Captain that were coming out with us and doing these missions. But it was very deliberate, every single one. And if there was a mission that we knew from our intelligence of the target area that the likelihood of women and children being there was nil, we did not bring the women, because we didn't see them as being necessary. It was exposing them to unnecessary risk if we were going to do that. It was an enabler we didn't need for that mission, so there were several missions that we did not bring the Lioness Teams. I would say probably 85 to 90 percent of the missions we did...and I'm just going to ballpark it here between all three firing batteries that went out and did that mission, the maneuver mission, probably upwards of 250 to 300 cordon and searches, knock and greets, or whatever you want to call them, required the use of Lioness Teams. [18:24]

Knarr: That's something. Now, kind of a timeline on things...so you were talking about November timeframe discussing the Lioness, discussing trying to get females to support

you. The first thing you mentioned using the Lioness' for is the TCPs. Then you talked about cordon and search and kill or capture. Can you kind of generally give me a timeline on when you did these?

Cabrey: I'll tell you, I want to say the middle of November is when we first discussed this. Within a week, we had the female soldiers out there with us doing the TCPs. Probably within two weeks we had them out there doing our cordon and searches, cordon and knocks. I mean, there are a lot of different terminologies. In all cases, the targets we were going after on the cordon and searches we wanted... somebody that we had intel on that basically we needed to bring this person in. They called them kill or capture in some cases, but, in most cases, they were not necessarily the aggressors. They could be an individual that we could directly link to attacks on US or Coalition Forces, but we had sufficient evidence to say that they were definitely facilitating the movement through or the funding of foreign fighters coming through. And I know, one of your questions, when I jumped down to it, "Did the women find information?" Yes they did, absolutely! And we called it Little Slips of Paper INT or LSPINT" instead of HUMINT or SIGINT. We would have the female soldiers search the female Iraqis in some of these houses. Sure enough, underneath their big robes and all, there would be slips of paper, ID cards, and little miniature phone books with some very key numbers and information that we were able to bring in the brigade on. They were able to find these, because we could search the women culturally correct.

Knarr: That's really kind of neat!

Cabrey: Everything that you could not find with a wand, you know, the metal detecting type wand. So, they definitely were value-added in multiple operations where we got, again, the LSPINT as we called it. [21:00]

Knarr: Wow, that is really interesting.

Cabrey: One of the reinforcing pieces of this is that I established a miniature town hall or community council. The CPA would let me call it a town hall, because we were moving ahead of what Ramadi had. So they let me call it a community council. There was an imam, who was one of the first imams I had talked to in one of the local mosques. There were probably three principals. We had a female principal, the Chief of Police, a contractor, and a lawyer that I met with weekly to prioritize projects for spending the CERP [Commander's Emergency Response Plan] funds in the town.

So, we meet with them every week. I was able to convince them that the Iraqi Government was going to put women into ministerial positions. There was one female principal that we'd worked with to help rebuild her school that I was very impressed with. She spoke English. Her husband had gone to school in the United States at Arizona, I believe for his PhD. She was very sharp and I was able to convince the Iraqis in our town to ask her to join this community council. But, in this council is when we're approached by them. A lot of times they didn't know who owned what area. The Iraqis weren't aware of the exact boundaries of our forces. But we did receive feedback from them that, "What we have seen is our people are much happier now that there are women that are out there. They're not violating us culturally. There are sensitivities that the American Forces are showing to us that we really appreciate." So that was the positive reinforcement we got from the Iraqis...that what we were doing made sense. [22:42]

Knarr: That's great. How long did you spend there? You say you had a RIP/TOA in September?

Cabrey: Yes, September '03 and then it was about the first week of September, second week of September. I crossed back down into Kuwait on September 11th, 2004 and filled back down from Iraq.

Knarr: Ok. And it was pretty much a continuance of the same mission during that entire year?

Cabrey: Through the entire year, yes.

Knarr: I look at that time in Ramadi, and well Ramadi was just as bad as Fallujah. It's just that we allowed them to develop a sanctuary in Fallujah. You had some hard times then!

Cabrey: It was difficult. It was a high stress environment. But, I know you've seen the film *Lioness*?

Knarr: Yeah, in fact that's where we picked up your name. Then I looked you up on AKO and found you!

Cabrey: The unique thing about that is when that first aired and hit the film festival markets, I got invited to go to the full frame film festival in Raleigh, Durham and spoke at that. Then as well as Tribeca Film Festival. The producers asked me to come. At that time I was at Leavenworth going through the Operational Arts Fellowship there. So, the CAC [Combined Arms Center], Leavenworth, had no problem with me going as somebody who could go to talk to that thing.

But what really came out of the movie was kind of unique, because the producers took a little bit of a different spin than what Dave Brinkley and I both thought they were going to do. They really focused in on a couple of the women who had a lot of issues coming back out of Iraq in that case. And I know you mentioned the 2/4 Marines in your email. Dave and I talked to the women. According to them, for a couple of those missions, 2/4 basically rolled up to the 1st Engineer Battalion said, "Hey we need some female soldiers to go out on a mission with us." They literally threw them in the back of the trucks and headed out. They were not very well rehearsed for the type of mission they were going out on. I think the women felt extremely vulnerable in a couple of instances. Their frustration comes out in the movie. Shannon saying she kicked the one guy in the groin after they left them for a little while running around out in the streets.

I had one instance where we had gone out to do one of those, I call them, "meet and greets" or engagements and a gun fight broke out just a couple blocks over. We then loaded everybody up. We had a couple of individuals that we detained because we found bomb making material in their house when we were walking through. We then went to where the police were in a gun fight with a group of bootleggers, if you will, just their common criminals. They asked us for help, and we said, "No, we're not going to. This is your mission. We'll help you by blocking a position a couple blocks over." I literally had some of these young ladies with their weapons and SAW machine guns hop out of the HWMVV and started running into the middle of it I had to pull them back and said, "Nope, nope, nope." They kind of kicked the dirt and said, "Gee, sir, you never let us have any fun!" I said, "No, I need you to stay here with these prisoners that we have." But, they were very, very, very professional Soldiers. I couldn't have been happier with them as combat enablers for us. They were definitely valued added to our team. [26:40]

Lieutenant Colonel David Graves: Sir, did those teams catch on throughout the rest of the brigade? Did the other units there use them?

Cabrey: The engineers were the only ones that basically provided women. The BSB, the Support Battalion, we had at the time or the FSB if you will, because they were down at TQ Airfield, they weren't readily available. They were about the only other unit that had female soldiers assigned to it. I think we had a signal company and a MI Company, but they were fully engaged in the brigade TOC and the intel collection piece. So, those soldiers were not readily available. [27:30]

But, like I said, Dave's engineer battalion with the females he had in his HHC, they were the ones that became the pool to draw from up in the Ramadi proper area. And so 1-16 Infantry, I think they may have used the Lioness Teams one or two times. I don't think that there were a lot of operations that Tom Hollis did where he had the women come out with them. Like I said the Marines used them a couple time. I think they were a little bit skeptical of the value added with the mission they had going on. It's amazing, just the geography of Ramadi—that one canal that separated us from Hurricane Point, literally canal not the river, and there was a different environment that they were involved with over there. Each area had its own quirks to it. But I think we probably used them more extensively than anybody else in the Brigade did.

Knarr: We're meeting with some of General MacFarland's people that had run the Lioness Teams for the Ready First Combat Team. They seemed to have done it out of the brigade. And of course they still went down to the 16th Engineer Battalion as kind of a source of female soldiers to use, but it sounds like Colonel Brinkley's the one that managed the source and set up the SOPs [standard operation procedures], vetting process, and all that kind of stuff for them. And the brigade really didn't have much visibility or control or management. They kind of let him do all that. Is that correct?

Cabrey: That is absolutely correct. Like I said, Dave and I walked into the KBR dining facility and talked about it over dinner one night. Then when we started doing it, we briefed the brigade commander on what we were doing and how we're doing it. But I think he and everybody at that time was pretty much of the mindset of well I guess it's ok. You know, so the tacit approval as opposed to, "Well, I'm not sure this..." What we really stressed was, "We're not putting women into direct combat. We're making sure that they can react to contact or react to combat." But again, as we looked at each type of mission and what the threat was and what the expectation of women and children on the ground was going to be, that's what drove us to whether or not we needed them as the enabler for each particular mission. The women were assigned to Dave Brinkley's unit. I think Captain Ana Breslow was the signal company commander. She was a Lioness and she went out on quite a few missions with us. But that signal company also fell underneath Dave Brinkley for ADCON [Administrative Control] purposes, so, you know, she reported to him anyway. But yeah, Dave was the guy that managed it. He's the one that vetted the women in these units to make sure that the ones that we were going to have as Lioness Teams were competent with their weapons, dependable, and that they were first and foremost Soldiers. So he was kind of the vetting sources for that and the go to guy for that resource.

Knarr: Yeah. Ok, that's kind of how I'd gathered it from the discussions. You know, this is 2003 to 2004. Did Patton come in with the 2nd BCT from Korea?

Cabrey: Yes 2nd Brigade, 2nd ID came in to RIP with us.

Knarr: Ok, and then I guess it was a BCT from the 28th National Guard from Pennsylvania that followed. I'm trying to draw a thread between what you guys did and what they did in Ramadi, because we're talking to them next week. But you had two Brigade Combat Teams that came in between that, and I'm wondering if they did anything with it?

Cabrey: Yeah, I'm not that familiar with it. I know that the 75th Fires Brigade Commander, Joe Harrington, who's here at Fort Sill with me, occupied my same headquarters. I don't know that he had a maneuver mission there, though. I don't know that his guys actually had the maneuver mission. He worked for MacFarland actually. [32:12]

Cabrey: And LTC John Fant was the artillery Battalion Commander that came in and replaced me. At least initially, I think they kept the same footprint we had, the same type of boundaries. But I know it was only probably three or four months into the rotation for them that John Fant's Battalion was moved out of the area, they were in, and they put, I think, 1-9 Infantry in that area.

Knarr: That's interesting. The Manchus?

Cabrey: Yeah, I believe so.

Knarr: That's really interesting. One of the things that we certainly appreciate in being able to do this project is all the unique things that came out of it as far as adapting to the environment.

Cabrey: Well, we were a learning organization; it was a very steep curb, but we were just trying to figure it out!

Hawkins: I have one question. The idea for the Lioness Teams kind of turns into the Female Engagement Teams in Afghanistan. And it moves from more of the physical aspect of searching to the engagements and talking with women to gain intelligence from them. Was there any of that kind of engagement going on or was it mostly just physical searching?

Cabrey: We did have intelligence requirements, I'd say PIR [Priority Intelligence Requirements]. Anytime we went out there was a purpose to us going out there. It might have been to inform the community on things, but we were also trying to find out whose husbands might be involved with the less than desirable entities out there. If there was in-

formation they could give us on black marketing of fuel or black marketing of propane, we figured the women were the most knowledgeable of that, and they would be willing to tell us that they're paying too much for things...electricity, those kinds of things.

I've got all kinds of photos of us at what we called them the Chinese Apartments. They were a great big complex of white apartment buildings in our area that we had probably 15 or 16 of those female soldiers, Lioness Team members that were with us on those operations as we were going out and engaging stairwells, floor to floor, knocking on doors, and talking to families. The female soldiers were very good at this. We set up interpreters with them. With groups of soldiers and the females, the female would be the one to engage with the woman of the house with an interpreter. And so we did have them doing that early on... helping us try to identify where there were problem areas in the community with black marketeering specifically. [35:17]

Hawkins: And so that was pretty successful?

Cabrey: Very successful!

Cabrey: We were able to identify a few issues with fuel distribution in the Ta'meem/Five Kilo area. We diagramed it all out, and we found out guys were coming from the fuel plant with a 10,000 gallon tanker. He would go to the gas station, if you will. He would give the guy 5,000 gallons for free and say, "Just don't tell anybody I'm keeping five, but you can take these 5,000 for free." The gas station would say, "This is great! I get 5,000. He gets to jack his price up and say that there's a run on fuel." Then the other 5,000 were distributed out throughout the community to 100 gallon tanks positioned in and around apartment complexes and those kinds of things. That guy then would sell his 5,000 gallons in 100 gallon chunks and then fuel was being paid for by cars pulling up on the side of the road. People had their own pump contraptions to pump out of these 100 gallon tanks. And so the women are the ones that told us about that.

The same thing happened with propane and the amount propane that was being delivered and how it was being delivered. We found that people were paying five times the price that the Ministry of Oil said they were supposed to be paying. So we went to the source, the propane factory. We put some pressure on him. Fuel/oil is the same way. It gave us an insight as to how to start applying pressure on a black market without collapsing it completely. You know, we had to be aware of what the Iraqi level of tolerance was for black marketing and not drive down below that. Otherwise it could create other potential issues. You know they would look to other forms of probably more serious or violent

crime to gain money. So, it just made us cognizant of where we could apply pressure and how much to apply.

Hawkins: Ok. That's good.

Knarr: You really had to think through what you did and the implications of your actions didn't you?

Cabrey: Yes. I loved every second of what we did. Don't get me wrong, I'd rather have been home with my family, but I left Iraq going, "I think we made a difference."

Knarr: Thank you very much!

Appendix B. Iraqi Perspectives

Notes on conventions used in the transcripts

- Ranks. The first time a service member is identified, their rank is spelled out; subsequently, their rank is abbreviated in accordance with their service affiliation. Ranks are spelled out in the footnotes.
- Time “hacks” on transcripts correspond to video so they can be used to identify areas to use as clips for the movie, the DVD and for further research into specific areas.
- For al- or Al- or Al in a proper name: When “al” is in the middle of the name, in a last name, for example, it should be lower case with a hyphen, such as Nuri al-Maliki. If the name is by itself then the “al” is capitalized, as in Al-Maliki.
- The majority of tribal names begin with the term *albu*, a formal characterization of *the*. When the tribal name is included in an individual’s name, the prefix “al-” is added and the tribal name changes slightly, usually with the addition of *awi* or *i* at the end. For example, Albu-Risha becomes al-Rishawi and al-Assafi denotes a member of the Assaf tribe or Albu-Assaf.

15 July 2013

Subject: Interview with Former Al Anbar Governor Mamoun Sami Rashid Latif al-Wani

Former Al Anbar Governor Mamoun Sami Rashid Latif al-Wani is a member of the Awani tribe and was selected as the Governor by the al-Anbar Provincial Council in 2005. His predecessor was kidnapped and killed and the Provincial Government was essentially disbanded prior to his arrival. Upon assumption of duties, he made his trips from his home in west Ramadi to the Provincial Government Center (PGC) only two miles away under heavy security provided by the Marines. The Governor's 12 year old son was kidnapped in September 2005, but returned after the Governor paid the ransom of \$6,000. Despite the killing of his predecessor, the kidnapping (and later return) of his son, and over 40 attempts on his life, the Governor continued to show up for work at the PGC.



On 7 April 2010 former Governor Mamoun was interviewed at an office next to the PGC in Ramadi by Dr. William (Bill) Knarr, Colonel Dale Alford, USMC, and Lieutenant Colonel David Graves, USMC. The following is his account of the Awakening. An interpreter was used for the interview.

Dr. William Knarr: Sir, can you first of all provide your background—where you grew up and what you did prior to 2003?

Former Governor Mamoun: I was born close to this area in Ramadi in 1950. This is why I love to live here, because I was born here. In 1987, I completed my college education in engineering. I got a job in Hadithah to do a huge project with the Hadithah Dam, which is a metal dam. Then I moved to the Al Qaim district and worked for three years in the railroad ministry. I moved to the Ministry of Housing and Buildings in Ramadi. My political life started in 2004 when I was elected. I served as a member of the 2nd Provincial Council here, and I was representing the engineers of Ramadi. At that time I was the assistant governor. On June 1st, 2005 I was elected by the original provincial council after the governor got assassinated. I was the assistant. In 2009, when the last election happened, I handed over the authorities to the new governor, and I am still here.

Knarr: Thank you. What caused the insurgency? [01:03]

Mamoun: In my opinion, the insurgency started because there was a vacancy [vacuum]. There was not a good or strong government that could protect the borders. There was no local government in Anbar or in the whole country. The reaction to the invasion in Ramadi wasn't thought through by people who thought about what they were going to do next, it was just a reaction. The people were affected by religious emotions and nationalism. I think the insurgency started when people tried to exploit the religious aspect of it. For example sheikhs and imams, they started giving religious advice to the people, provoking them to fight against the Coalition Forces. And the soil was fertile and the environment was ready for Al Qaeda to come and exploit the people. There were a number of reasons why the insurgency started. The first reason I am going to give you is a historical reason. [Slight interruption]

It's a very important first point that is historically known, but needs to be documented. The Coalition Forces had a lack of knowledge of the culture of the Iraqi people, specifically of the Anbar residents. On other hand, the Anbaris did not know how to react with the American Forces, because they were distracted. The imams were giving them religious advice. They had the politicians giving them different advice. They had the existing politicians and the politicians that came in after the invasion from the outside. So the Anbaris had so many people giving them so many views. And the sheikhs gave them orders to do something also. They were confused. There were so many orders at the same time. [7:21]

The goal was to liberate Anbar from the invaders, but there were so many views. Because there was no balanced view people started fighting with each other. With this vacuum (of no guidance) and all the fighting, Al Qaeda won the hearts of the people at that period of time. People started adopting the Al Qaeda mentality and ideology. So basically, there are three points: the lack of knowledge and education of the people; the influence from the countries and politicians from the outside; and the lack of knowledge of the coalition forces with the Anbaris and how to deal with them.

We started meeting and we started talking with the Coalition about how to [reach a goal]. This is when we started challenging Al Qaeda. Al Qaeda started acting abnormally—started killing and kidnapping people. One of the people who was kidnapped was my own son. They started to sabotage the infrastructure and the government. There was no legitimate reason for them to blow up the mail facility in Anbar. What's the reason for blowing up the schools or the bridges? It started to look obvious; it was a mechanism to

destroy the country and not to rebuild it. At that time, the picture started clearing up about the identity of Al Qaeda. The first goal to fight Al Qaeda or the first weapon to use is the inner belief that these guys are the enemy! It's very hard to convince the people. You cannot flip them from supporting one group to immediately being hostile against that same group. Then the Iraqis started understanding the Americans and the Americans started understanding the Iraqis. The coalition effort to understand the Iraqi culture was a huge effort starting with General Williams all the way through General Allen and General Reist. The Generals' understanding changed the balance. [13:14]

I forgot to tell you one of the biggest problems. It's the most important thing. Anbar province is based on a tribal community...all the way from Karmah to Qaim. Each one of these tribes has its own idea and translation of what's going on with the events in the province. They don't have the political knowledge or teaching. They didn't have moderate imams at that time or moderate leaders. It was a very complicated era. Sometimes you have to have meetings to talk and to convince these people...a lot of communication. I'm a true believer in communication to reach your goals. God created us not to fight. He created us to live together. This is our whole goal. There was a lot of resistance at that time, people had to resist. And a lot of times, we had to build so we could show the people that we're builders not destroyers. American efforts were very important to show the people they were building. And people will anticipate a good ending for the coalition. We traveled in this sea and it was a rough ride. People have different mentalities. People have different goals. We and the American side were riding this boat. And thank God we have all been blessed and successful, because good always wins over evil. I am quoting an old comment, "As long as the night is so long, at the end of the night we're going to see the morning sun."

We succeeded in defeating Al Qaeda on these four points. The first one, we made sure to expose Al Qaeda that didn't have any religious basis. When we were building and they were destroying, that exposed them that they are the destroyers and we are the builders. We exposed them that they're not promoting life and happiness. They are promoting crime and killing. The fourth one, they're not careful about people's lives. They destroy people's lives. They're not accepted in a civilized way. When the people saw all these four points, they started to support the coalition and this is when the Awakening started. [18:40]

After the Awakening started, other tribes started understanding and accepting the idea and started joining in. When we started fighting Al Qaeda in Fallujah, the fight started to trickle down to Al Qaim, then Hadithah, then Anah, Rawah, and all these cities. The

tribes with the help of the coalition forces, they took the fight to Al Qaeda. The last round of fighting was in Ramadi. The Awakening Council, especially in Ramadi, it took a different shape. It started in a specific number of the tribes. It was led by Sheikh Abdul Sattar Abu-Risha. That was just like throwing a stone in clear water, to see all these circles. We were the ones who threw the stone and then the circles started. And this is when it started. We started the Awakening Council, and in the same token, the support by the people and the tribes to Al Qaeda gradually started fading.

I always think that it's three basic principles. When you achieve these three basic principles, this is when you start a face off. First of all, the men of the government and the Coalition forces; it doesn't matter if it's at the national government or the local government. An understanding started evolving between the local government and the Coalition forces. And the tribes; we were always looking to add the third principle to this equation, which are the tribes. When we had all three elements of the equation, we started fighting Al Qaeda. When the tribes came in and joined and united, it has been called the Awakening. Thank God it didn't take very long! It wasn't a very pleasant ride. They had ups and downs. The minute you have a miscommunication or any issues between these three elements, you're going to have problems. It's a rule of surviving anywhere in the world, if there's no room for people living easily together, they have to fight. We started to change the perspective of our community, because it had so much oppression and lack of education in our society. And when we changed it, we got good results. Hopefully we are not going to go back to the dark nights! [24:56]

Knarr: You talked about the tribes from Karmah to Al Qaim. You talked about Fallujah, Al Qaim, Hadithah, and then you talked about Ramadi being last. Can you talk about the various tribes, Abu-Nimr in Fallujah, Abu-Risha, Abu-Mahal, and Alwani here in Ramadi? Can you tell me how the tribes started to come out as that third leg, as they came out in each area and how that evolved?

Mamoun: As I said these three elements, when they started coming together, for example, in Al Qaim, the Abu-Mahal tribe joined us in Al Qaim. It was the first tribe before any other tribes to join us. It was a good result there. In Hadithah the Jughayfi tribe was the first tribe to understand the three elements. We had good results. With the Al-Ubayd tribe in the Baghdadi area, we had a quick result there because they had a quick understanding. In Hit, Abu-Nimr had a mutual responsibility and a good understanding of the situation. But in Karmah there were delays. Why? It was a little hard, because they had so many different tribes in that area. Karmah had very different, big tribes including Hal-

absa tribe, Alwan tribe, and Jughayfi, and Jumayli Tribes. This is what delayed it. Karmah was like the whole of Iraq. They have so many borders with so many other provinces, and it was very close to Baghdad. There was no understanding between them and the forces in Baghdad. Criminals were passing that area very easily.

They were also bordering Samarra. Karmah delayed to be stable, because of all these things. Look at Ramadi. It's not controlled by one tribe. There are so many tribes. When people start gathering around Sheikh Sattar, God bless his soul, at least four to five tribes—his tribe, Albu-Risha, Albu-Diab family, and Albu-Shilb, and Albu-Assaf, Alwan, and Albu-Souda. That's what I meant when we threw the stone. Now we have the circles going bigger and bigger.

Knarr: For so long you came to work in 2005, and you were the only one that came to the Government Center. You were so committed and so dedicated, but it took so long. Where did you find the commitment to everyday go to work when it seemed so hard? [30:57]

Mamoun: Faith. Faith in God. That God will stand up with the right people...and the understanding, and this country, the faith in my country and my province. Part of our success is working hard to get the Americans to understand our culture. In the beginning, we didn't talk about the misunderstandings or the distance between the American forces and the local government. They did not have any understanding in the beginning. For example, in one of the incidents, I was working in 2004 as the assistant for the head of the Provincial Council. I was arrested by U.S. Forces. I was surprised! I met with the general. It wasn't General Williams...it was before him. They didn't understand my thoughts about the whole subject. We passed on the misunderstandings and a whole stage of not understanding each other. It wasn't easy at the beginning.

After a while we had a mutual understanding and goal to overcome Al Qaeda, and we did. One of the greatest principles I believe in is communication. If people understand and adjust and communicate about any new situation that evolves, we can solve any problems with people. Look at the government and the capital. Look at that how they're fighting right now. If they sit together and communicate, one, two days, two weeks, by a month they will solve all their issues. One of the things I noticed in the states is how much building and how much advanced technology they have. And even the people...if they don't have the understanding and know how to live together under one country and love each other and the country, they would have never reached that. If the principal is to live together, everybody will be happy and all humanity will relax. [36:15]

Knarr: General Allen tells a story of the governor and the government center as a young boy and he had a vision of being governor and of what democracy and government was all about. And that's one of the reasons he said you had this inner feeling of just having to come every day. Can you tell us about that?

Mamoun: I told you that in the beginning, because I was born here, right up the street. The government center is right in front of my house. I built this myself...it's a principal to love my country and my province. I grew up with this principal, so Al Qaeda can take nothing from me. Any true belief that you want to make it happen, just put it as a principal in your heart and it will work. Just like a man loves his wife and kids. It's a small example, but if you have a wife and start a family, that's it, you're going to have principal in your life, something to care for.

Knarr: Is your son ok? You said he had been kidnapped.

Mamoun: This year he will go to the university. Hopefully he will be better than me! He wasn't affected by the kidnapping. I was affected more than him! Now my son is doing well. It's a good thing that my son saw these criminals, and he knows them for real, so I don't think they will ever affect him. Our faith in God and the right thing will make us stronger and stronger and I know that God is with us. I love my country.

Knarr: For the Awakening, you mentioned the government of Iraq and you mentioned Maliki. Did you receive any help from the government as you were working with the tribes and trying to bring the three groups together? Did Allawi, Jaafari, and then Maliki provide any help?

Mamoun: Everybody helped out. At that time we had more American assistance than the government of Iraq. Mr. Maliki visited us in 2007. He and plenty of his ministers, heads of the states, assistants too.

Knarr: They talk about the Awakening in Al Anbar, but then they also talk about the Awakening up north in Tikrit, Mosul, and then the south of Baghdad. What influence did the Awakening here have on the rest of Iraq?

Mamoun: The Anbar Province Awakening was the proto-type. We're the ones who started it. Because the other areas are still built on some kind of tribal infrastructure of the community, they have the three elements and they started doing just like we did in Anbar. The understanding created and prepared all these certain elements and created the Awakening Council. The reason why the Awakening was very strong and effective in Anbar

was because the three elements were on the same page. They had a very strong understanding of each other to make it. If you look at other Awakening Councils in other areas, maybe they were not as strong as the Anbar one, because the three elements were not on the same page and didn't have that much understanding, so they delivered according to the percentage of their understanding. You cannot blame or give credit to only one element. It's all about these three elements that I am talking about. This is why, again, I say as long as there is understanding, there is a good environment for living.

Knarr: What did I miss? What question should I have asked that I did not ask? [45:02]

Mamoun: Victory always is within reach for the brave. The problem is keeping the victory. That's the most important thing. Now I have a question for you. All the victory that we established with the brave, do you think people will appreciate it or something started happening now that it is unstable? Hopefully you can answer.

Knarr: Well, with people like you here to make sure things are right, I think it will work.

Mamoun: It is very important to know and understand that the American element in this whole deal is very important. It's a very good, big, and sovereign country that has many experiences. Hopefully you will remember the sacrifices you made, and hopefully we don't have to make them again. Because the people forget very fast.

You have a great experience with democracy and you always keep the victories. I'm not talking about military victories, but victories in being civilized and having your country keeping its democracy experience. I thank you for these questions you had and the whole subject.

Alford: This is an honor for me. I served here in 2005 and 2006, and I watched what you did back then when things were really tough. I look forward to seeing the sheikhs and the mayor out in Al Qaim.

Mamoun: You are one of the leaders to teach this successful recipe.

13 May 2010

Subject: Interview with Sheikh Ahmed Bezia Fteikhan al-Rishawi, Paramount Sheikh of the Abu Risha Tribe on the Awakening

On 22 April the JAWP Sheikh Ahmed Bezia Fteikhan al-Rishawi, Paramount sheikh of the Abu Risha tribe and President of the Mutammar Sahwat al-Iraq (The Iraq Awakening Party - MSI) was interviewed at his Guest House. Sheikh Ahmed was the brother of Sheikh Sattar Al-Rishawi, founder of the Sahawa movement. When Sheikh Sattar was assassinated in September 2010 Sheikh Ahmed became the leader of the Sahawa movement that subsequently transitioned into the MSI political party and was represented in the March 2010 elections.



Sheikh Ahmed, Abu Risha Tribe

Sheikh Ahmed was interviewed by Dr. William (Bill) Knarr, Colonel Dale Alford, USMC, and Lieutenant Colonel David Graves, USMC. An interpreter was used for the interview.

Sheikh Ahmed Bezia Fteikhan al-Rishawi: Please my pass regards to General Allen. I did a lot of work with him since last we spoke.

Colonel Dale Alford, USMC: He's a hero in our court.

Dr. William Knarr: Sir, first of all it's an honor for us to be here to talk to you. You and your people have made so many sacrifices, and it's an honor for us to come and talk to you.

Ahmed: I am very happy to meet you, Dr. Knarr.

Knarr: I would like you to start by talking about your tribe. Could you talk about the background of your tribe and their long lineage?

Ahmed: Some of the Abu-Risha tribe is spread out in Baghdad/Fallujah, but the most of it is in Ramadi. Grand-grandfather, Nasser Suliman Abu-Risha, the 5th grandfather, down to the 3rd grandfather, Sheikh Fitkhan. He led the revolution against the British. After my grandfather, my father became the sheikh of the tribe. And before my father died, Coalition forces entered the country.

My brothers Khamis, Muhammed, and Sheikh Sattar and me, had the chance to do a peace treaty between the Iraqi Forces and the American Forces. I was the counter part for organizing

this with the Iraqis. The person responsible for the Iraqi Troops was General Hamid Dumayl Jubari. He was the Anbar Operating Commander. God bless their souls, Muhammed, Khamis, and Sattar called the Coalition forces in area 160. We told the Americans we are not going to fight you. Are you coming here to fight us or to take Saddam Hussein out of power? The Coalition forces advised me that they were coming to take Saddam Hussein out of power. They were not here to fight me. We proposed the peace treaty, so we didn't fight each other. Of course, the Coalition forces asked the sheikhs to try to bring the Iraqi Army to the table for the peace treaty. We promised them to bring the commander of the IA [Iraqi Army], to them. [5:08] We received a promise that Coalition forces would not arrest the IA leader if he didn't reach an agreement with them. I went and talked to the general and convinced him to go with Muhammed and Khamis to the area 160 to communicate with the negotiators. The general and his XO went to the meeting. And we had the peace treaty, and the Coalition forces entered Al Anbar without fighting. They let go of all the Iraqi Army that existed in Anbar, and the US Forces came in.

After that we established the government in Al Anbar and an IP [Iraqi Police], we were successful for a year. At that time the tribe didn't have its own political party. Some of the opposition parties that were outside of Saddam's regime came with the Americans. At that time they started talking about resistance, and they were pretending that they didn't come with the US Forces. They pretended that they came after the US Forces. They started organizing resistance against the US Forces. This is when the terrorism started. They made a temporary government, and they did not let them participate in the government in 2005.

Knarr: Who made the temporary government, the outsiders?

Ahmed: The Americans. A lot of decisions were wrong and it wasn't studied. One of the points was dismantling the Iraqi Army and leaving the Iraqi camps open to the civilians. That means that all the weapons caches were transferred to the unorganized government militias. From that temporary government there were a lot of laws established including the voting laws. It was a mess. [9:33]

At that time, Al Qaeda came into Iraq to fight the American Army. Some of the political parties cooperated with Al Qaeda. Some of these political parties were paying off Al Qaeda and talking to them and trying to make peace deals, so they could guarantee their safety. Our tribe did not fall for this trap, and we refused to make any deals with Al Qaeda. Al Qaeda killed my brothers, Ali, Muhammed, Sattar and my father. We noticed that Al Qaeda controlled Anbar and the government and had all the entrance/exits in

their hands. It ends up that the Anbari normal people were being raided from the US Army. They got arrested by the Iraqi National Guard, and they were getting killed by Al Qaeda, to include teachers, doctors; all the educated people. Al Qaeda dismantled the police force and killed approximately 1,600 IPs. The only forces left at that time were the US Forces and the government center and some of the high buildings. They were fighting back and forth between Al Qaeda and the US Forces. Coalition forces contacted leaders of the tribes, the sheikhs, to try to get them back to establish IPs. The sheikhs from the big tribes sent 500 guys.

Knarr: Who initially made contact from the Coalition?

Ahmed: General Williams. He sent us aid. This is in the beginning of 2006. This thing failed, because one suicide vest came in and blew himself up in front of 500 guys and killed 60 of them [This is the Glass Factory recruitment incident in January 2006, to be discussed more later]. Al Qaeda made sure that they killed all the sheikhs that met General Williams in that meeting. They killed General [Muhammed Amil Jubawi] and [Sarawi], who is another general in the IA. Anybody who tried to participate in this matter, they killed them. Colonel Dean from the Army came to Camp Ramadi. I told the Colonel that the city was in the hands of the terrorists, and they were controlling it. [15:16] I told the Colonel about when I was an officer in the Iraqi Army and that I participated in the Iranian/Iraqi War [that we had developed a plan]. So we developed a plan to take back Ramadi and Anbar in general. The colonel said, "First of all, we take 150 fighters from each tribe. We'll make our own IP Station in the tribe, and it will be outside the city. Then we start attacking the city from these IP Stations, to take it back." The colonel was convinced. He told me: "Let's start with your tribe. Bring me 150 guys. This is in the 6th month of 2006." I asked him, "Where do you want me to bring the 150 fighters?" He told me, "To the glass factory."

I told the colonel, "Last time somebody tried to do recruiting at the Glass Factory, Al Qaeda had an s-vest, and you couldn't protect them. So, what I am going to do is I am going to invite the 150 guys to my house." I had 150 fighters come the night before and slept overnight, and in the morning the Coalition forces came and they did the testing for them. I predicted that because Coalition forces and the tribe members were meeting here, there would be mortar attacks from a distance, so I advised the Coalition forces to extend their patrols in Al-Jazzerah area. He told them, "Don't worry about it, keep going." Two hours after we started, we started getting mortar shells. Coalition forces started being

apologetic, and they said they wanted to withdraw, because they were causing us harm by their presence in his house. I said, “Don’t worry about it. Stay. Let’s continue.”

Knarr: Now, that happened here? [19:02]

Ahmed: Yes, right here. I told him, “Don’t worry about it. We’re used to being mortar shelled by Al Qaeda. Plus, we have our experience with the Iraq/Iran War, where being shot is not a big deal.” They finished testing them, and shipped them to Amman, Jordan. In the 7th month of 2006, they would be trained.

Knarr: How many where there all together? You said 150 from each tribe.

Ahmed: Just my tribe, 150, because they started only with my tribe in the beginning. Me and Sheikh Sattar, God bless his soul, started contacting the other tribes’ sheikhs. I advised them, and told them to do the same. Just copycat us and send 150 guys and this way you open your own IP stations and then you can protect yourself from this organization. We talked to them separately. It took me two months almost, to get all the approvals from the other sheikhs. On the 14th of September, this is when we had the meeting. It’s called the Sahawa Meeting of Anbar. I gathered all the tribe leaders. I was going into the UAE at that time. My brother asked me where we had organized the meetings. It was going to be on the 14th. He asked if he could come. I told him, “Please proceed. Do whatever you’re going to do with the meeting, because I have a lot of contracts to sign in Turkey after UAE.” After that the meeting was established Sheikh Sattar called Colonel MacFarland. He’s from the Army.

Knarr: Yes, I know him.

Ahmed: The Colonel understood and trusted the Awakening meeting, but the government in Baghdad tried to influence the military leader in Baghdad and advised him not to trust the tribal guys, because they don’t always keep their words. Colonel McFarland talked to his superiors. He said I guarantee these guys. I feel they’re truthful about what they’re going to do. The 150 IPs that we trained in Amman came in and opened this IP Station. It was the first step—an encouraging step for the rest of the tribes to do the same thing.

Knarr: Where was the IP station opened?

Ahmed: Right here. Yes, it’s a small house. They started taking actual houses of people and making IP station out of it. We still have this house here. Sheikh Sattar paid the rent for that house from this man, not the government. We did it. Then all the battalions from the Marines and the Army came and helped us out in training and educating the tribal lead-

ers to get them on track. I went to Amman and met with the other sheikhs there and got their approval. The approvals I got were submitted to the government in Baghdad to give support for Sheikh Sattar, so we could fight Al Qaeda. Sheikh Sattar, God bless his soul, went to Baghdad. He met with the Prime Minister. He got his support, an approval, to get his guys armed. He went and met with the Minister of Interior. He got approval for him to hire 9,000 IPs from the tribal members.

They then had another meeting with all the sheikhs. They told him, "We don't want to have the appearance of being militia men or tribal men. We need to look as formal and official as possible. They complained that they didn't have any uniforms, so we went and got uniforms. We paid for it from our own money. We had them wearing the IP military uniform. We advised our IPs, we don't want any needless killing. Anybody you arrest, bring him to us and we will put him in our jail that is being supervised by US Forces. And then you do your investigation, file it, and document it, and keep it with us until the court system opens up again. Even the court system wasn't operating at that time. It was under the threat of Al Qaeda and it wasn't operating. This started building the trust between us and the Coalition Forces. Americans saw that we are organized. It's not a militia, and it's not uncivilized. They started bringing IP trucks from the government and giving them to the IPs here. We opened IP stations in all the tribal areas. We also start opening recruiting centers for the PSF [Provincial Security Forces] forces. Of course, including this IP station, which was the first one. After establishing all the IPs and establishing the PSF forces, for almost four months, we didn't get paid officially from the government. They would pay us just a little bit, but not enough. The US Forces started doing some projects in the tribal areas, like fixing schools and doing a lot of PRT [Provincial Reconstruction Team] work. At that time we had General Allen come into the Al-Anbar area. General Zilmer, General Gaskin, and General Kelly. [30:27]

Knarr: And you had Charlton?

Ahmed: Colonel Charlton was the area commander. Colonel Johnson...these guys fought side by side with the IPs. I remember that we'd sit together, me and Sheikh Sattar, bless his soul, and the General and make plans how to attack Al Qaeda in uncleared areas. We remember how they deliberated with a plan out of this house...for clearing Habbaniyah, Tash and the Ta'ameem area. All these plans were made by me and Sheikh Sattar and the American Army. I wanted to go and fight in the Habbaniyah battle. But the general told me that I couldn't go because I was the tribal leader and if something happened to me, it would be his responsibility. Plus I wasn't the military man, so I couldn't go. I told him, "At

least let me give them support” He said, “You’re not going.” I told him let me go at least let me give them some spiritual, moral boost. He said, “Just do the planning, and don’t worry about it.” We had a few casualties in these battles. They kept fighting for a whole year, almost. Just two days after the one year anniversary, Sheikh Satar got killed. [33:18]

Knarr: You mentioned the building of the IP station. When was the first IP station built?

Ahmed: It was in September 2006.

Knarr: Sheikh, you talked about a second meeting. The first meeting was 14 September, but the second meeting was important also. Do you recall when that 2nd meeting occurred with the tribes?

Ahmed: I am trying to think. 50 days exactly after the 1st meeting. At that time this started the IP stations to be distributed all over the tribal areas. This is when they gave us all the uniforms for our IPs.

Knarr: Sir you said that the Minister of Interior helped you and supported you, who was that at the time?

Ahmed: Jawad al-Bolani. That’s the first. The one he signed was for 9,000. Mr. Bolani is the person who backed up Sheikh Sattar and helped him out the most. This is why I joined forces with him in the recent election even though I know he’s not a winning party. He used to help us with all the equipment. After establishing the IPs and being successful, Sheikh Sattar and I got a letter from General Petraeus. The letter explained to the sheikhs that a lot of the IA units don’t have enough people in them...the Anbar tribal guys were not participating in the army. Some of the religious leaders had a statement that said it’s haram¹, it’s forbidden for people to join the IA. That happened before the Awakening. It affected the Anbar people. This is why they refrained from entering the IA. [37:44]

I told Colonel Charlton to talk to General Petraeus...that we were going to be able to help you out and convince some of the tribes in Anbar to participate in the IA. They asked for at least 5,000 from the tribal guys to go to the IA. We talked to the tribal leaders and got 5,000 names. We had an appointment with Jawad, and he said we only need 2,000 for the first step. The first stage would be 1,000 and the second stage would be 1,000. We said, “You asked for 5,000, and we got you 5,000.” You go tell them you only

¹ Arabic word meaning forbidden in Sharia law.

need 1,000. The American commanders were saying that they ask the central government “Why aren’t you taking Anbaris to participate in the IA?” And the central government says, “Well the Anbaris don’t want to be joining the IA.” The commander said, “Now I can tell them we asked for 1,000 and we end up with 5,000.” We brought all the media in to record these guys and say, “These guys all want to participate in the IA.” And of course this went all over the TV, and the government immediately agreed to take all these 5,000 guys.

We got them all approved. It was generated for Anbar to have 11,000 IPs. Because of the international percentage, each 130 citizens have to have one law enforcement officer. The 11,000 IP were not meeting the quota that was established for Anbar. General Allen, Governor Mamoun, the head of the Provincial Council, Salam, and I went all the way to Baghdad to meet with the Minister of Interior. We told him that we need more than 11,000. We told him about the international percentage quota. The Minister of Interior told us that the international percentage quota applies.

But we don’t have a regular situation here. We have the IPs fighting Al Qaeda. We have a huge province that accounts for a third of Iraq’s total landscape. We have three international borders around this province: Jordan, Syria and Saudi Arabia. Plus we have a 600 kilometers stretch of highway, so the standards do not apply. This is an exceptional situation. So they gave us another 9,000. Then we had 20,000. And the Minister agreed and gave his approval. The General told me that I’m a great negotiator. After we got all the 20,000, General Gaskin said, “We’re going to make it 30,000.”

We went back to Baghdad with General Allen, and we got approval for another 10,000. Now we have 30,000. After we got the approval, we had almost 30,000 salaries and families getting paid. We had five extra thousand IAs, so we had a total of 6,000, because we had 1,000 before. We have 2,500 of the facilities security personnel. This created financial stability to the families.

We needed to do something about the University of Anbar. It was not working at all. We only had 20% of capacity of teachers. The students weren’t able to study. Only some of the faculty went to the offices. Al Qaeda was under control. At that time, we had some Coalition Forces inside the university. We also had the National Guard coming from Baghdad to secure this facility. We have zero female students going there and a few male students. It wasn’t operating whatsoever. Then I talked to Sheikh Sattar and told him we need to open the university and let the people go back to school and study. He agreed

and decided to get Coalition forces and the National Guard out of the university and replace them with the IPs to protect the university.

Me and Colonel Johnson went to the university and met with the Dean, the head of the university. The president of the university was upset to see Coalition forces there. He didn't want their presence whatsoever there. The Sheikh talked to him and said we have to open the school. We will take the Coalition forces and the National Guard out. We know you are getting threatened by the Al Qaeda, so we are going to provide you security from the IPs. My idea was to put the IPs in the school or at least at the perimeters of the school as guards. The IPs will be people from the province, so they will be familiar with local population and they will have mutual trust. The same day we pulled the US troops, they pulled the Iraqi National Guard. We put an IP station, and within one month we had 100% attendance. During the mid-semester examinations, the General helped us to take fuel for the generators, and we established the first successful mid-semester examinations with the Coalition forces help. [50:31] The same thing happened at the end of the semester. The Coalition forces helped us out with the fuel, which gave us the lights and helped us to type the examination papers. We had two SVES [suicide vest] come into the IPs. They shot one from a distance and the other one blew himself inside the IP station. This was just in the beginning. IPs still man that post, and they didn't hesitate whatsoever.

We thought about it, and the tribal leaders said, it's not going to be enough. We have to bring the religious leaders, like Jalal, and Thamir, because Al Qaeda is fighting in the name of [God], thinking that they are truly religious. We had a meeting on October 4th, 2006 with the Islamic leaders. We advised them that they needed to talk about Islam. They had to get their point of view across by talking on the TV and in the mosques to explain the true Islam, which is not killing people and slaughtering them. I told them about the true Islam, which is about life, building, and education. The Islamic leaders and the scientists said, "We need your protection." They got permission from the general to give Sunni waqf² protection. And they got it. They gave us around 60 guys to protect the Islamic leaders and the waqf. The IPs started circulating and made a cordon around the mosque. They invited people to pray and they educated them about what Al Qaeda was doing. In the beginning, the mosque was controlled by Al Qaeda. They were doing propaganda through religion against us. Then we took it over with the IPs protection.

² Arabic word meaning endowment.

Knarr: Was this in Ramadi?

Ahmed: It was spread out. After Ramadi it spread out all over Anbar. [58:46]

Knarr: During the summer of 2006, we heard there were a number of events that really helped turned the tribes against Al Qaeda. One was the killing of a sheikh, but I don't know anything about that.

Ahmed: Sheikh Khalid Arrat of the Albu-Ali Jassim tribe. He was a good person.

Alford: Where did he live?

Ahmed: He lived in Jazeera. His son is here, if you want to meet him. He is one of the leaders. I can't talk on behalf of all the tribes, but I am 100% sure that the two tribes that Al Qaeda could not operate off their land was Albu-Risha and Albu-Chulayb tribe, which they're right next to each other.

Knarr: In 2005, Albu-Mahal fought Al Qaeda. Did Albu-Risha help them?

Ahmed: At that time the Minister of Defense was from the Albu-Risha tribe, Mr. Sa'dun Dulaymi.

Knarr: That's right.

Ahmed: I contacted Sheikh Sabah and asked him, "Would you like us to help you, send you some money to fight the Al Qaeda?" Sheikh Sabah, "No, we don't want money, but if you can talk to the Minister of Defense and tell him to get out guys enlisted, so we will be able to fight these guys." My brother Khamis, God bless his soul, went into Baghdad and talked to Mr. Sa'dun Dulaymi and told him what we needed. The minister told me, "We cannot give you weapons, understand, because you are not official, so you have to go in and enlist first." After my brother talked to Mr. Sa'dun, the minister sent a helicopter with Sheikh Kurdi, the head of the tribe there, and he brought the names with him. The minister immediately approved the names and sent them the weapons and uniforms.

Knarr: Sir, we have met with Sheikh Jassim, and he talked about the help that you gave him and Sofia in November of 2006.

Ahmed: Yes, he came in and asked for help to open an IP station. We got them approval, but from the Coalition Forces. The minute he opened that IP station, he got attacked from the Al Qaeda that resided in the adjacent Albu-Fahad tribal area. They killed 17 of his guys, and Sheikh Jassim's guys killed 50 Al Qaeda guys. I remember after the incident, Sheikh Jassim came here and Sheikh Sattar, God bless his soul, Albu-Risha gave him support,

financial support, weapons, aid for all the guys who had their houses burnt, and they dropped them off across the river to go to his tribe. At that time Coalition forces came in and attacked from one side of Sofia to assist him. And there was a Captain Patrick. They use to call him Hasham Abu-Risha. His name is Patrick, but we used to call him Hasham Abu-Risha, because he was so close here. He died in Ramadi.

One of the IP station in Ta'ameem is called Shahid Shama Abu-Risha. They gave that name for him. Hasham Abu-Risha's real name is Captain Patrick³. I think he was Special Forces.

Knarr: Yes, I know who you're talking about.

Ahmed: He was a good friend. A couple hours before he died, he was here with me. One hour before he died, he took some of the kids in my house here and went to the orange trees, and he was picking oranges and giving them to the kids. He was on the ground eating with them. He got dressed, went to his mission, and one hour later the news came back that he lost his life. Colonel Lechner was one of his very close contacts. Sheikh Sattar Abu-Risha called. He told him I want you to get me the guys who killed Captain Patrick. And he got him. Sheikh Sattar gave these guys to American Forces, and told them, these are the guys that killed Patrick. The forces put them in jail...maybe they're out now.

Knarr: What did I not ask that you think that American students need to understand about the Sahawa?

Ahmed: Are you planning to invade another country. Is that why you ask me?

Knarr: No!

Alford: Maybe we could learn something to help Afghanistan. [1:10:39] You mentioned Sheikh Kurdi. We had dinner with him two days ago.

Ahmed: I mentioned him without even knowing that you were with him.

Alford: And General Ismael from 3/7, too. We had dinner with him.

Ahmed: He's the commander for the 7th division.

In the beginning the Coalition forces depended on parties and politicians. The beginning was with the sheikhs, and it was a very successful beginning. When the Coalition forces

³ Captain Patrick is actually Captain Travis Patriquin.

and the tribal leaders initially gathered, they had temporary governments and a very successful ruling at that time. There was a lot of influence from the opposition party that came from outside the country. They told the American forces that, “These tribal guys are not educated. They’re not going to be very good.” On the other hand, the American Forces wanted a very democratic government, and unfortunately the tribal leaders did not have any political parties to participate in this democratic process.

There was so much political influence to get the Coalition forces away from dealing with the tribes. And what added to that was the previous experience, I think, that Coalition Forces had in Afghanistan—that one or some of the tribes turned from supporting US Forces and joined the Taliban. These two things [negatively] influenced the Coalition forces from dealing with these guys. You can tell this is a lesson learned when Coalition forces went back again to deal with the tribal leaders. It worked very successfully.

It’s very important to learn the lesson that you cannot exclude one side. You cannot deal only with the sheiks and not deal with the party or deal with the parties alone and exclude the sheikhs. You have to deal with both of them, so you can be successful. I have to put each of the societies in its place and give them their ground play. [1:16:44]

After the first election, the Provincial Council Elections, and when they had won the elections, the Coalition Forces came to show respect and congratulate them and they asked me, “You fought against all the odds. We thought about it you should have left here, because Al Qaeda killed six of your brothers and family members and you were getting threats and you’re not getting help from the government. So logically you should be out of here. But you stood up and you became successful!” I told them, “We’ll learn from wars. If somebody killed one of my family, I am not supposed to leave. I should stand up and get that person who killed my family and stop anybody else from killing my family.”

Al Qaeda hurt Islam so much. Since September 11th, the terrorists have given society the idea that Islam is all about terrorism. I told President Bush when I met him at the White House that when September 11th happened, we couldn’t express our voice, because everything was controlled by the government. General Allen was with us at that time. Saddam Hussein had very different views with you and of course we couldn’t put our voice out, because it was controlled by the government. We couldn’t denounce this act. What we did on September 14, 2006 until this day is our way to say that we condemn what happened to you on September 11th and what we did to Al Qaeda it’s enough punishment for them for what they did from September 11 to this time. The President accepted

our speech, and he believed it honestly. He extended the ten minute meeting to an hour and fifteen minutes. General Allen told me the President only had to sit with us for ten minutes, and I stayed for an hour and fifteen minutes instead. That means what we're doing is good and important. [1:35:00]

You know the Army has the duty to protect the cities from outside. Saddam Hussein tried to place blame on American Forces by putting the Army inside the cities. We believed that when the Coalition forces entered Anbar from the desert they would see the tanks and the Army, and they would attack the civilians by attacking the Army. So we informed them that we will not attack you and we will let you enter the city in peace. So we arrived there, and we told them that we will reach an agreement without fighting. We succeeded in doing this. When Al Qaeda attacked, they attacked everything. They attacked the civilian, the houses, the children, and the women. Sometimes when the Americans attack a house which involved, Al Qaeda member, all the media, Jazeera and others, tried to show it and make it a huge deal. They don't talk about the crimes of Al Qaeda.

After the Awakening, we convinced the Coalition forces and we started showing the soldier carrying the wounded children who were attacked by Al Qaeda and moved them to the hospital. That was not shown before in the media. I asked General Allen and Charlton to put all this in the media and to show how the American Soldiers saved the wounded people and how Al Qaeda killed and injured people. We took pictures. We documented this good behavior of the American Soldiers. We put it on the media and deliver it to the people. Also we distributed this media to the Imams, and we showed these pictures in the mosques. They showed the crimes of Al Qaeda and good behaviors of the American Soldiers. You can see how the soldiers treated the wounded children.

There was an American Soldier who stayed a month with a young child in the hospital. He stayed all month taking care of her, because the father and mother were killed through in an Al Qaeda attack. General Gaskin gave him a medal, and I put that medal on the soldier, because of his patience and taking care of that child. We were looking to separate the good behaviors of the American Soldiers between the people. Sultan Hashim, the previous Minister of Defense is still in jail. I visited Ambassador Crocker, and he was a very understanding person. The central government sentenced General Sultan Hashim to be executed, and the other generals were also sentenced to be executed. They were very good fighters through the Iraqi/Iranian War. I mentioned this to Ambassador Crocker that I want this for history, that government sentence, the Minister of Defense to execute him. He promised me not to deliver Mr. Sultan Hashim to the Iraqi Government. And the Americans didn't

deliver Sultan Hashim. He's still alive, and he's still in jail. This is for the history—that America didn't execute the Minister of Defense. [1:44:11]

He [Ambassador Crocker] was very brave, and he came here to Al Anbar and we went walking around the city. We entered the city inside the market, and he was carrying his jacket. He bought some things from the market. I tried to pay for him, but he refused. He said “No, I want to say I went to the market of Ramadi and bought these.”

We arrived at the area where the headquarters of Al Qaeda was, there in Ramadi, inside the city. He was looking for a gas lamp. We didn't find it. When we moved to the new location of the Embassy, I bought three gas lamps and said, “Because you moved to this new location, this is a present for the new location! When you don't have electricity power you can use it.”

Knarr: You mentioned that you had met with President Bush, did you put those pictures in here? [Sheikh Ahmed provided us a copy of photos and videos.]

Ahmed: [Yes] President Obama, also. In last meeting with President Bush, I talked with him in the White House. In my last meeting with President Bush I told him a historical story. There were two fighters, fighting with swords. One of the fighters injured the other one. He told him, “Either kill me or save me. Don't leave me just wounded.” So the other knight saved him and they become very close friends. So, I informed President Bush, “Don't leave us in this way...”

Alford: That's a good analogy.

Ahmed: “Don't let us be occupied or controlled by Iran. Help us or try to do something. Don't leave us in this way.” He thanked me for this story and this explanation for the situation of United States and Iraq.

Islam says you cannot kill anybody who did not try to kill you. Again, God forbids in our group. It's like religion not to kill any human being. It doesn't specify if it's a Jew, Muslim, or Christian...any creature or human being God created, you cannot kill him. I think that Al Qaeda got paid money to jeopardize Islamic views for people to think about Islam in a different idea. We always say that anybody who wants to be bad to the Islam religion, go and join the Al Qaeda. And they said if anybody wants not to be Muslim and convert his religion, go join Al Qaeda, you'll be non-Muslim. I am bringing up this speech from the prophet Muhammad. One of his speeches says, “Honor for who fought

him and honor who dies fighting him.” Remember when you went to the big room and saw all these pictures on the wall?

Knarr: Yes.

Ahmed: That’s my father and all my brothers that got killed by Al Qaeda.

Alford: Your family has sacrificed much. That’s one of the stories that the Dr. will tell.

Ahmed: The pictures are only of close family members. I didn’t put up my nephews, my cousins, all these others. Even my brother-in-law of my sister was killed. He didn’t have a tribe here. My son is a Lieutenant Colonel here.

Knarr: Most Americans can’t even imagine that happening to their family. I mean they can’t even conceive of it.

Ahmed: The day we went to the wake to bury my father and brother in the cemetery, the rest of the tribe told us not to go to the wake, not to go to the cemetery. I asked them, “Why?” They said, “Because Al Qaeda may be waiting for you, and they’ll kill you.” So I told them, “First of all we’re not better than the one we’re carrying on our shoulders, and we hope to beat Al Qaeda. So we take our revenge, but we still have the dead bodies of our families.” When we were ready to go to the cemetery, I advised the US Army and told them, “We’re going to bury my family. We are going to be armed and ready to fight Al Qaeda guys. We are ready to fight continuously for two days. The problem is you’re not going to know who Al Qaeda is because they’re all in civilian clothes.” So the Coalition forces stepped back. We went to the cemetery and buried our dead. You’ll see how bad their criminal minds are. After ten days of being buried, Al Qaeda went to the cemetery and scraped the graves and splattered all over them, because they want to challenge [desecrate] them.

Alford: Sheikh Kurdi was one of the first to stand up against out there, so he’s my brother now, forever.

Ahmed: Sheikh Kurdi is the bravest out of all the sheikhs in that area. He was stronger than Sabah.

Alford: Sabah left. Sabah went to Jordan.

Ahmed: We call them Amman sheikhs.

19 May 2010

Subject: Interview with Dr. Thamir Ibrahim Tahir al-Assafi, Professor of Religious Studies, al-Anbar University, on the Awakening.

On 12 April 2010, Dr. Thamir Ibrahim Tahir al-Assafi, Professor of Religious Studies, al-Anbar University, Senior Theologian to the Sunni Endowment (waqf), Ramadi City Council Member, and member of the Council of Muslim Scholars, was interviewed at Sheikh Ahmed's guesthouse on the Albu Risha compound. Dr. Thamir started the interview by stating that he, and many other Iraqis, hated America because of the war in 1991 and the subsequent embargo imposed on Iraq. Although the intended consequence was to put pressure on, and punish Saddam Hussein, the reality was that the national infrastructure, education, health and many other services that supported the people were the casualties of those sanctions. He also asserted that there was no terrorism in Iraq before the Americans arrived in 2003.

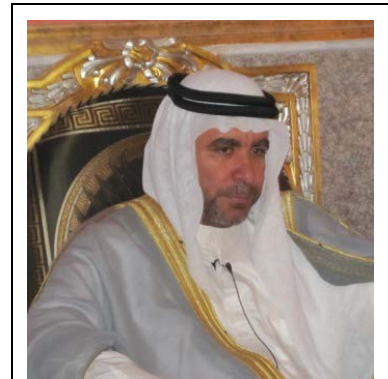

Dr. Thamir, Professor of Religious Studies

Dr. Thamir was interviewed by Dr. William (Bill) Knarr, Colonel Dale Alford, USMC, and Lieutenant Colonel David Graves, USMC. An interpreter was used for the interview.

Dr. William Knarr: First of all, please provide some of your background? I know that you're a professor of Religious Studies and you're the senior religious person within Al Anbar. Can you provide some additional background?

Dr. Thamir Ibrahim Tahir al-Assafi: I am a doctor with a PhD in religion and Arabic language. I am Dr. Thamir Al-Assafi, and I have been an Imam for a mosque since 1991. I taught in several colleges. I taught in a school for teachers and in a couple of secondary schools, too.

Knarr: Were you born in Ramadi?

Thamir: Yes, I was born in Ramadi.

Knarr: Can you start off by talking about the insurgency. How and why the insurgency started and how it developed?

Thamir: First of all we have to describe terrorism and identify terrorism. The general idea of terrorism for people is that truly religious Muslims are considered terrorists, which is a wrong perspective. People are not born as terrorists. It is related to the environment that the person grew up in and the mentality of that person. Outside influence too, will push a person to be a terrorist.

Before 2003, before the American invasion, people in Iraq did not have any of these terrorist ideas. There were no killings. Maybe just a small group of young men had the Jihad mentality. In 1991 after the invasion of Iraq to Kuwait, the defeat of the Iraqi forces, and the embargo on Iraq, everybody started hating America to include myself. I am specifically talking about Iraq. Within the embargo years, we had our children dying in our hands. We had the old people dying because of the embargo, so we developed this hate. The ugliest name to hear at that time was America. Plus, the media of Saddam's regime was feeding us hate for America every single day. So the whole perspective of America as the one responsible for the embargo and for the death of all these children and old people is how the hate started. This is why everyone gets excited when they hear an explosion or a Vehicle Borne Improvised Explosive Device (VBIED) happen at an American Embassy outside Iraq. This is how terrorism got breeding ground. The problem is when the Coalition forces attacked and invaded Iraq seven years ago, they did not have any background about the people here, about their mentality. The only background information they received was from the Iraqis living in the western countries. The people that the US got their knowledge from had been living outside Iraq in a western country. They were changed, and were not the same Iraqis that were living in Iraq. [7:43]

Knarr: Like Chalabi?

Thamir: Just like Chalabi. He robbed Jordanian banks, and now he's a very famous political person. Most of these guys are ex-criminals and ex-murders who committed crimes and then left for the states and western countries. Now they're back as murderers running the government.

A reason for this hatred [Iraqis for Americans] is that when the US invaded this country, the Army and military personnel viewed the civilians as the enemy. It wasn't an equivalent relationship. A military person from a different culture did not understand the civilian he was dealing with. Even the generals from the Coalition forces who invaded Iraq, they dealt with "want-to-be-Sheikhs", people who were pursuing the relationship for just the money and for contracts. They didn't deal with the real Iraqi people. These guys,

they were feeding US Intelligence with false information, which created more hostility between the US Army and the people on the ground.

The minute Saddam's regime fell on April 9th, 2003, the Sheikhs and the political figures in Anbar gathered together. We looked at the governor and the Chief of the Police, and we wanted to hold the system together. We only had chaos for 24 hours after the fall of the government in Baghdad. After 24 hours and the election of the political figures in Anbar, security was completely established in Anbar. A few days after the American forces entered into Al Anbar the people tested them, because they were occupying their country. So they had a massive protest in downtown [Ramadi]. The Coalition forces did not respect this, and they rolled in with tanks. Because of the disrespect of the Coalition forces coming into the peaceful demonstration, the protesters started throwing vegetables, stones, and chairs at them. The second day, the same things happened. They had a protest in Ramadi city and the Coalition forces rolled in and shot and killed a 20 year old person. You have to understand that Al Anbar is a tribal society, and the tribal society is built on revenge. If somebody killed someone from your family, you have to go and take someone from that family. So, because of this incident, the family of that deceased person tried to get revenge, because if they didn't take their revenge, they would be dishonored. So, they started the first armed resistance group against the Coalition forces, and that was the spark. [14:50]

Knarr: When was that?

Thamir: About 15 days after April 9th or 24 April. That was the spark, but the original reason to add to that spark was when the Coalition forces came in and destroyed the infrastructure for the government. There was no police and no functioning government, so there was a huge power vacuum. I am going to give you some examples of what happened. After the invasion, there was no government. All the weapons that belonged to the Iraqi Police (IP) and the Iraqi Army (IA) got into the hands of the civilians. It was a disaster when the IA left their positions after the invasion. There were huge weapon caches that belonged to the Iraqi Army. There were all kinds of weapons, from heavy to medium to small arms. It was easier for a person to purchase a missile than to find a bite to eat. The borders were completely open and you had a lot of Arab fighters who held a grudge against the US for entering Iraq. A lot of Arab fighters were in Iraq in the first place.

After the regime crumbled, the Iraqis helped these foreigners get out of [escape from] Iraq. After a while all these fighters came back to Iraq. The Iraqis, specifically Anbari-

ans, paid with their own money to let these guys stay in their homes. The borders were open, and they found people to train them, they found people to finance them, and they found people to set them up. The people suffered from the killings from both the American soldiers and from the terrorists. For example, the terrorists will stand up in front of a tank and start shooting at the tank with small arms, which is not going to do any harm for the tank. However, the tank will shoot at that person without aiming, and it will kill a lot of people causing collateral damage. If an IED (Improvised Explosive Device) blows up on a US convoy, the actual people will pay the price. [20:32]

There was another thing happening. All the US snipers on top of the high buildings were having fun picking off people. A person going back to his house, carrying stuff (food or whatever items) in a plastic bag to his family, they will just snipe him for the fun of it. They were killing between 10 and 15 people a day, just having fun sniping people. I went personally to meet General Williams. I was talking to him, and [explained] that they need to stop this from happening. I threatened the general after talking to him. I told him that we as Anbar people will [cause civil unrest.] We will stop dealing with them and all Anbar citizens will be against him if he doesn't stop the killing. The general tried to explain to me that, "We're trying to fight terrorism. This is only collateral damage." I told him, "I can take you right now. I'll ride with you in your HMMWV [High Mobility Multipurpose Wheeled Vehicle] and we'll show you where the terrorists are. They are 100 meters away from you in the gas station across from the movie theatre." The terrorists have control of all the gas stations in Ramadi, including the gas stations on the highway. The American Forces, right in front of these gas stations, will just look at the terrorists controlling them. They know they're terrorists, and they never bother them. The main focus for the Coalition forces at that time was to only respond to somebody shooting at them, but they didn't care about the terrorists that were killing other Iraqis. I witnessed with my own eyes, terrorists killing Iraqis on the highway, and the Coalition forces just drove by and did not interfere at all. [25:15]

Knarr: When was this?

Thamir: It was '05-'06, all the way to the beginning of '07. All this pressure on the regular Iraqi civilians built up a grudge against the Coalition forces. So this is how the US soldier became the most hated person in Iraq. Plus, terrorist groups were coming across the borders, and nobody was stopping them. Al-Qaeda controlled all the government offices and establishments. If you look at the government facility, you'll see a manager there, but all of the decisions and funds go to Al-Qaeda. They controlled the education system.

The same principal that President Bush said, “If you’re not with me, you’re against me,” was Al-Qaeda’s, “If you’re not with me, you’re against me.” They would kill the teachers, the religious leaders, and tribal Sheikhs. They were killing everybody related to the Iraqi Security Forces (ISF), previous officers, new officers, and enlistees. If they couldn’t kill them, they would destroy their homes, or they would kill their family. They didn’t discriminate against any ISF Forces. [27:56]

The people couldn’t handle it anymore. They were in a dilemma. They couldn’t fight to protect themselves, because the Coalition forces prevented them from owning arms. They had to stop this thing even if it took putting their hands in the hands of the Coalition forces to stop this terrorism. This is what happened in September of 2006. In September 2006 Sheikh Sattar, God bless his soul, gathered a bunch of tribal and religious leaders together and started the seed of the Awakening Council.

People heard about that meeting, and started coming in and joined the Awakening Council, including myself. I came in and had a meeting with Sheikh Ahmed and Sheikh Sattar, God, bless his soul. We started helping to bring people to get into the police as an IP officers or IPs. This is how we kicked Al-Qaeda and terrorism out of here. [30:40]

Knarr: What are your thoughts on radicalism versus moderates? Where were the religious leaders on this?

Thamir: When we go to preach at Friday prayers, people are advised that it’s against Islam to be extremely, extremely strict. All the ideas of the takfirians are not accepted by us. Our religion advises us to negotiate and talk with the occupying forces before engaging in a fight. You have to have communication first, and then you can engage in a fight. I have to distinguish between hating the American people and hating the occupying force; it’s two different things. I advise the people not to hate the actual American people. Our people stood up and resisted the occupation. As occupied people, we have a legitimate right to resist, but by the same token, we absolutely condemn the civilian killings caused by all of these terrorist acts in London, Madrid, and other parts of the world. We are against innocent people dying; it’s against the religion and against our ideology. This is why we feel pain when any of these explosives happen anywhere in the world.

As I said, we did not have extremism here before the invasion. All this happened when Al-Qaeda came into the country. Whoever joined Al-Qaeda from the Iraqi society is the lowest of the society. Everyone was trying to blame Imams that they were joining Al-Qaeda, but any educated person, religious person, or educated religious leader would

never join Al-Qaeda, to be an advisor for Al-Qaeda, or try to recruit for Al-Qaeda. These guys are well educated. They know what's wrong and what's right, and this is why they didn't join. The problem is when Al-Qaeda came here after the invasion, they occupied all the mosques in Al Anbar. They brought their own Imams to control these. [36:32]

Al-Qaeda took over these mosques, and they put in their Imams. They would bring Imams preprinted statements, and give it to these Imams to say. Al-Qaeda took over my mosque and put somebody from Al-Qaeda into it. I had several attempts on my life. A lot of the good, moderate Imams who had their own mosques had assassination attempts on their lives. Al Qaeda basically had occupied all the mosques.

[Translator Change]

Knarr: The religious aspect is so important to this, and people forget about it. We hear about the government, we hear about the people, we hear about the Coalition and the security forces, but the fourth leg of this is the religious aspect and the influence that they have. What are your concerns now with what is going on in Iraq from a religious aspect? [39:12]

Thamir: Religion depends on the person who is preaching the religion. My philosophy is moderation. I don't want extremism, and I don't want people to leave religion, just to be in the middle. Obviously, you did not learn the Islamic religion, or you didn't study Islam before you invaded Iraq. In the Islamic religion, we deal with the enemy one way, with friends from a different religion another way, and Muslim friends another way. It depends on the situation. In the Islamic religion, if you are against me or if you're my enemy, we're going to deal with you differently. We still have laws and rules on how to deal with you. I mean, we're not going to be against you and that's it.

To give an example, the prophet Mohammed dealt with the Jewish, Christians, and Muslims at that time in one way when they were fighting, but other than that he treated them well. That's why a lot of Christians and Jewish people converted to Islam, because they saw that he was fair. The Islamic religion teaches us to deal fairly with the Christians and Jews. We call them the 'Holder of the Book,' which is the Bible. In Islam, if you kill a Jew or a Christian, you're not going to go to Heaven. This is the way Islam is. So, all this time we were dealing fairly with the Christians and the Jews until the extremists came in. Also, our Islamic religion says that you cannot have revenge killing. If someone kills my brother or my father, I'm not allowed to go and kill him. I have to go to the law and get the law to take care of him. If I take the law into my own hands and everyone

does the same, then it will be chaos, so we have to go through the law, through the judges, and through the judicial system to take care of this. [46:49]

I ask your help to change the situation here in Iraq. All this happened because of the invasion, and now we're seeing that Iran is getting big. I am talking about the politicians going to Iran and meeting over there to decide who's going to lead Iraq. The Iraqi people are very smart, and they're looking at you to see what you're doing. You have to do something otherwise it's not going to be good for Iraq. We're looking forward to democracy in Iraq, and for the Iraqi people to live in peace. We've been living in war for too long. Now I think it's time for them to start living in peace, to forget the suffering they had for too long, and to become good people again. I want to emphasize that the Iraqi people are not sectarian. The sectarians are the politicians who are controlling some of the population, and moving them towards a way that will benefit them. Even the last bombing that happened in Iraq, we don't see the politicians as innocents. [50:57]

Knarr: What are your feelings about America now?

Thamir: I visited America, and I gave a lecture in City Hall. I was very impressed with the American people. They are good people, and they are different than the soldiers that came in the beginning of the invasion. I visited some American families, and I have some friendships now. I went to Washington, and I was very impressed with the people and how they treated me. I was in Washington, and it was like I was in an Islam country. They treated me very well. After that I went to Raleigh, and I met with some Muslims there. They were telling me that they have good relations with the Jews, with the Christians, and with everybody else, so I was really impressed. The Iraqi people are good people, and they forget very fast. If the Americans come and destroy a building in Kuwait or Saudi Arabia or any other country, the people in that country hate them forever. But with the Iraqis, if you do that and then you show them that you're sorry or that you want to work with them, they will forget that you destroyed that building and they start becoming your friend. [54:52]

Knarr: We've found in talking to a number of people here that Iraqis are very friendly.

Thamir: Iraq is the birth of civilization in the world. It's very, very old.

Knarr: The cradle of civilization.

Thamir: That's right. Abraham, the God of the Jewish people, started here in Iraq. All of civilization started here in Iraq, so the Iraqis feel very attached to this soil. They are good

people. The Iraqis look like they are a simple people, but we are educated. We are good people, and we can bear the suffering, no problem. If the dictatorships that have happened in Iraq happened in any other country, that country would be demolished. But the Iraqis can take it. The things that happen to the Iraqis, the suffering, is like an experiment. So even though we are simple, we know about a lot of things; we are very intelligent people. [58:29]

Knarr: I don't have any more questions, but I would like to say that I know you are a high level professor and scholar, and the purpose of doing this is so we can educate the people in the military on your perspective, and on what the Iraqis think about the insurgency and the Awakening, so that we can learn from this.

Thamir: Are you trying to invade another country, too?!

Knarr: No, no, no.

Alford: To reinforce why we are here. The Joint Chiefs sent Dr. Knarr here to document this for three reasons. First, he's a PhD in Education and Training, and he has a great reputation for this kind of work. Two, like he said, it's for educational purposes in our command and staff colleges and our war colleges for our senior officers. And number three, and I think most importantly, that you brought up sir, is we'll never make the mistakes that we made in '03 and '04 again by learning from this.

Thamir: I thank you for listening.

19 May 2010

Subject: Interview with Sheikh Abdullah Jalal Mukhlif al-Faraji, Director of the Sunni Endowment for al-Anbar, on the Awakening.

On 10 April Sheikh Abdullah Jalal Mukhlif al-Faraji, Director of the Sunni Endowment for al-Anbar, was interviewed at Sheikh Ahmed's guesthouse on the Albu Risha Compound west of Ramadi. Sheikh Abdullah is from the Faraji tribe. Sheikh Abdullah became an Imam in 1993. On 18 August 2005 in an attempt on Governor Mamoun's life in the Dawa Mosque, Sheikh Abdullah was wounded in the arm and went to Jordan for treatment. Upon his return he was arrested by the Coalition for unspecified charges. The intervention by BrigGen Williams to release Sheikh Abdullah developed a bond between the two men and was an indication to Sheikh

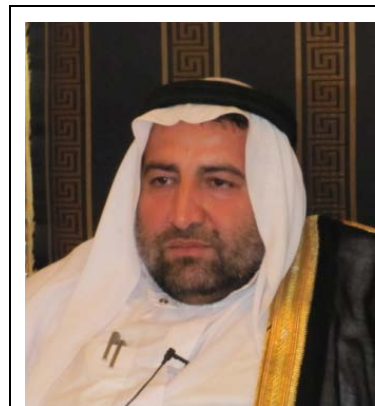

Sheikh Abdullah Jalal, Imam

Abdullah that the Coalition could be fair in dealing with the Iraqi people. In 2007 he publicly issued a Fatwa against Al Qaida, although secretly he had issued the Fatwa much earlier. Along with Dr. Thamir, Sheikh Abdullah is the senior Sunni Imam in al Anbar Province. He provided leads to Lieutenant Colonel Michael Silverman, USA, LTC Thadeus McWhorter, USA, and BrigGen Williams, USMC and passed his special thanks to COL Charlton.

Sheikh Abdullah Jalal was interviewed by Dr. William (Bill) Knarr, Colonel Dale Alford, USMC, and Lieutenant Colonel David Graves, USMC. An interpreter was used for the interview. The following is his account of the Awakening.

Dr. Bill Knarr: Sir, could we start off by you providing some of your background information? Were you born in Ramadi?

Jalal: By the name of the God, thanks to God, first of all welcome. Welcome to everyone, and thank you for this study. Don't keep this for yourself. I want you to show this story to everyone.

I was born in 1963. I finished elementary school, middle school, high school, and college. I also finished the Islam College. I [have] a Master's [Degree] in History. Now I am studying as a Doctor in Islam. I've been on the Sunni's Council.[5:31, Audio recorder]

First I will talk about the conditions before the insurgency started. When the Coalition Forces came to Iraq, some people said, "They're invading our country" other people said, "No they are bringing freedom here." The Americans think they saved us from tyranny, but the Iraqi people have a different [perspective]. What I want to tell you is the strategy for this war is basically different from the old wars. What we would like to know from all the military in the world is the new strategy about the war. Sometimes you can avoid an entire war with your thoughts, and sometimes you can invade a country with one word. But, everybody is going to lose something in war.

The strategy for the war right now, it's basically different from before. So I would like to advise the American, the Coalition Forces, don't use power against weak people. There are a lot of educated and smart people in the American Military. We would like them to use their brain and see how they treat other people. We'd like to talk [to] the strong man, not the weak one. Sometimes we're surprised. Sometimes we're surprised when we see some American Soldiers killing children. Incredible thing, you know. First of all, you need to change the military's ways in Iraq. That's one thing. [9:36]

Another thing is how the Coalition came to Iraq. Every country that is invaded by another country has to defend itself. This was the mujahedeen. They wanted to defend their country. But when the insurgency started, that's a different thing. How the insurgents got in this country? I am going to tell you how. The reason was the Coalition. The first mistake was the Coalition left the borders open. We have a lot of neighbors around us, and the border was open. So basically, it was an opportunity for them to get inside this country. Second, Paul Bremer broke down the Iraqi Army. Third, they didn't pay attention to the militant guys. They didn't pay attention to the religion guys. I'm one of them. They didn't pay attention to me at the beginning of the invasion! There are a lot of different ways to control people with religion in Iraq. Sometimes they can make a difference.

Back in 2005 there were some American leaders that knew what we wanted to do. We told them that the insurgents are outside of Islam; they're not Muslims. As you know, the insurgents don't [differentiate] between humans. If you're not with them, they will kill you. They killed a doctor who did surgeries for the people. He saved people's lives. They killed an engineer, so he wouldn't build any more buildings. They wanted to destroy everything. They want to kill the Muslim who is not with them, the Christian, and any religion. It doesn't matter what kind of religion, they don't believe in it. They just kill. They don't [recognize] any difference between religions. There are only four main religions in this world...its four books, Muslims, Jewish, Christian and Buddhist and in our areas

right now there's some people who believe the cows or the trees are gods. So, if you go and join the insurgents, you are the right person. If you don't join them, it doesn't matter what religion you're coming from.

I was in a big council meeting. They [insurgents] told me that they are not really insurgents, and they are following Islam. I told them, they're not, they're insurgents. I am telling you right now, count how many Muslims the insurgent killed in Iraq, and count how many Jewish people got killed by the insurgent and see the difference. There are a lot [more] Muslims who got killed than Jews. It's a huge number, a huge difference. From different religions, they killed more Muslim than any religion, so they don't belong to us. The infidels and the insurgent, they do not belong to Islam, never, never, ever! [16:15]

Knarr: In 2004 and 2005 some of the mosques put out anti-Coalition types of messages. I'm curious, was that religious message? What types of messages were the mosques broadcasting?

Jalal: The reason was the Coalition Forces never put their hands in our hands to work together. They probably helped the tribes, but they didn't pay attention to us. After we sat down together in 2005, we understood each other. We started talking about things. Everything started cooling down. I know a guy his name is General Williams. He is American Commander, American leader. He has very good connections with the religious leaders and we started helping people. We started from 2005 to 2006, working together with the Coalition Forces. The people [insurgents] used to use the speaker and say bad things against the Coalition Forces. They are gone. You know that the insurgents, they have a different way to use their insurgency against the people. They killed many of the sheikhs of the tribes. They also killed many people, really good people, commanders in the Iraqi Army (IA) and Iraqi Police (IPs). They killed doctors, lawyers, engineers, students.

Knarr: Did they kill the religious leaders, too? [19:57]

Jalal: They killed more than 100 religious leaders in Al-Anbar province, only in Al-Anbar province. More than 400 Sunni religious leaders got killed in the entire country. Every religious guy who wanted safety here, he got killed. Almost ten times they tried to kidnap me. [They tried to] blow me up with Improvised Explosive Devices (IEDs) on my convoy. They shot me and my family with mortars. For four months they attacked my house and around my area where I live. I fought them face to face one time. We had a big fight. We had the machine guns, face to face. It was a big battle. I fought them with Governor Mamoun when he was a governor.

Knarr: I read that you were wounded.

Jalal: He was something like three meters from me with a PKC machine gun, and he shot me. He was wearing a mask. We were using all of our own power. We kicked them out of the city.

Knarr: You issued a Fatwa in 2007 against Al-Qaeda. Can you talk about that?

Jalal: Before 2007. It was a secret in 2006. When Sheikh Sattar came in with Awakening people, he saw that the religious leaders were on his side. He is a really a good guy, a good fighter, hero, you know. All of these people were waiting for me, the religious person... We can't control the insurgency without the Awakening. When the Awakening showed up it helped us a lot! We started working together with tribal, religious, and civilian people, and also the local government. We started helping, so we started working together: tribal, Awakening, local government, Coalition Forces, and religious leaders. Also, when I am talking to you, I am not going to forget how we were working together with the Coalition Forces. They gave us permission to carry weapons and to fight the insurgents. Right now, the Coalition Forces are still helping us, and I'm appreciative for that – thank you! They were our enemy in the beginning. Now they are our friends. [25:03]

Knarr: I think you went to the United States with other clerics as a part of Provincial Reconstruction Team (PRT) supported efforts. Can you discuss what the conference was about?

Jalal: Our meeting was about religion. We met some [people at] the Pentagon, scientists, and religious leaders. We also visited more than five states, and visited different colleges there, too. We talked about how religion moves people and makes people do good things. I was thinking about how we can talk to each other, the Jews, Muslims, Christians, and the people who believe in the cow and the tree. They are always living in peaceful lives. They don't fight and they don't do any bad things. But the four main religions don't sit down and talk to each other. So I am going to repeat again, the Islamic religion allows us to eat with the Christians and the Jews, to get married [to] them, even if she's not Muslim.

Knarr: You are the Director of the Sunni Endowment Fund, and I know that you have distributed food to the poor. What else? I am curious, what other things do you do? [29:40]

Jalal: First of all, the religious side has to be patient with the politician, the security, and also the population, the families. Do not differentiate between the people you live with or you work with. A few months ago I was having a Council meeting for the religious side, and there were a lot of people there. They told us how to rebuild the human being. It was a

meeting about how to rebuild the human. We need to show them the right way and the bad way. If we build the personality for the human beings right, there will not be any bad things in the world – no more killing, no more wars. These things [killing, wars] happen because people don't believe in their religion. The Quran and the prophet Mohammed encourage us to learn about science from when you're born until you die. I'm not saying all this for Muslims only. This is in general. I am saying this for all the people in the world, because our relationships are still not awake; they are still sleeping. [33:59]

Knarr: You know the power of the Fatwa, you encouraged people to vote during this last election.

Jalal: Before the election for like three for months, I was having meetings with all the Imams in Al-Anbar. That's why I voted. If somebody didn't go vote, what are we going to say about him in an Islamic way? If anybody didn't go vote, he's going to be a sinner with God. That's the first time we sent this Fatwa in an election. To be in this political process, you have to go do it. There were a few religious guys outside the country who gave the Fatwa to tell the people not to vote in this election. Because we are inside [Iraq], we destroyed their Fatwas. The election was fine.

The election was all alright, but to tell the truth, the Awakening political party didn't even get anything in this province. In the news and in the media, the reason why is that the Awakening as a political party was late to do their job in this province, but they still handled everything as far as the Awakening. The reason was the Parliament. It's all about the money by the people. There were a lot of parties who tried to buy votes.

I want to say this: Sheikh Ahmed deserved to be in front.

As religious men in Al-Anbar and this government, we are on his side. Some other country is going to tell you the religious guy is not beside him. We are beside Sheikh Ahmed Abu-Risha. I don't belong to anybody else, but I'm saying the truth. Abu-Risha is doing the right thing. I wish all the good things for all the people, not just for him also. [42:57]

Knarr: What are your concerns for the future?

Jalal: There is a son of a DoD interpreter. His name is Kandar. I gave him a phone call about a month ago. I asked him how long it was going to take to set up this new government. In his opinion it was going to take a week. I told him, "It's going to be at least seven more months, probably, to set up the new government." The Americans found the democracy, that's what they believe. Also, Iraqi politicians also founded the democracy. That's what

they believe. And us as religious leaders, we support democracy. But our neighbors are controlling the country, not the politicians, not Iraqis, not the Americans, not the religious leader. How are we going to serve this new government when our neighbors are controlling everything, and the Americans are just watching us? They have to do something! Just separate all the politicians, Shia, Sunnis, and Kurd from Iran. This is an American responsibility, our responsibility, not the Iranians. Now, everything is set up for the Iranians. They are ready to invade. [47:33]

If we are not going to pay attention, we are going to get hurt. As you know, we can't do anything right now. We don't have weapons, nothing. It's just a crazy. I can't believe that it's happening in Iraq! Iran, they are trying to destroy Iraq, without any reason. They support Hezbollah in Iraq. They also support Al-Qaeda in Afghanistan. [They] destroyed Pakistan. They are the reason that Al-Qaeda is in Europe and everywhere. All of that is the Iranians fault. They also have offices in Washington. I saw them [with] my own eyes. It's crazy; I couldn't believe it! They're not afraid. They're probably going to invade the entire world. We don't care if the Americans invade the world, because when they invade, they are also help. They're not killing people. They save lives and help the people, but the Iranians are monsters. [49:43]

Knarr: I've asked you a lot of questions, but it's based on what I know. What didn't I ask? What do you want the American military to know, that you have not yet said?

Jalal: I am happy when I see some religious people in the American military. It encourages me; it makes me happy when I see some religious guy in the American Army advising the soldiers. This is very important thing to let the people know what is right and what is wrong. As you know, the devil is inside the human being's blood. That's what almost all of the religions say. The soldiers and the military needs to be educated.

We need to raise a different military in this world. [We need] to make them not think about the differences between religion. We need all the militaries in this world to be working together against all the bad people, against the bad Fatwas. When the insurgents give Fatwas, a lot of people believe it. [55:32] I still blame the US intelligence. It made big mistakes in the beginning and they are doing it again right now. What were their mistakes in the beginning of the war? The US intelligence told the entire world there were nuclear weapons in our area. No, there is nothing. We can't do anything about it. Today the intelligence knows, and they don't tell the people the right thing. They're still doing mistakes. They know who the insurgents are. They know who the politicians are, who

the Republican Guards are. They know all this stuff, but won't tell it to the right people in the American military. The religious parties are just separated from politicians. They don't listen to them. The government doesn't mess around with religion. There's a huge difference between religion and the politics. There is probably 70–80% of American people are Christian. Right? That's why America succeeded.

I remember when the infidels were doing the bad things with the insurgents and then they returned to the Awakening as a good people. The insurgency is like a disease. It's a cancer. There are a lot of people that have the cancer. They want to work with the insurgents, but after we talk to them and advise them, they return to be good people. [1:02:06]

We need this study. Every country has problems like Iraq, not just us. We need to study the religious concept, tribal, political in Afghanistan too, not just in Iraq. How do we succeed? What's the reason you failed? You need to study all this stuff.

Where I come from, the tribes and religions, the Iraqi people, wish for the American military. We wish they go outside the country, and go back to their homes and see their families after the things cool down. But, we don't want them to pull back to the States and leave Iraq in this situation. We have found agreements, the agreements we signed between the US and Iraq. If the Coalition Forces pull back their forces outside Iraq, this country is going to [be] destroyed. I talked [to] the Ambassador about many things, many issues. I saw him on TV. He talked a lot about these problems. I was watching him. He said, "From today we're going to rebuild the new Iraqi government," But where is it? We wish that what the Ambassador said would happen. [1:05:55]

Knarr: I would like to thank you. You have sacrificed so much. Americans need to understand. They keep saying it's the government, the tribes, and the Coalition, but it's also the religious leaders.

Jalal: I asked Williams before, "If somebody is going to shoot the tank with a pistol, why do you shoot the entire neighborhood?" I told General Williams, "Excuse me, there's a fly on some cow's nose. How are we going to kill the fly? Are you going to slam it or what? Just let it do whatever it's going to do? If you slam it, you are going to kill everybody around it."

6 August 2010

Subject: Interview with Colonel Ahmed Hamid Sharqi, Chief, North Ramadi Police Precinct

Colonel Ahmed Hamid Sharqi, chief of the North Ramadi police precinct was one of the first police leaders in Ramadi City and saw it progress from total lawlessness and AQI controlled to a manageable level of violence.

On 7 April 2010 Colonel Ahmed was interviewed at his office in the North Ramadi Precinct by Dr. William (Bill) Knarr, Colonel Dale Alford, USMC, and Lieutenant Colonel David Graves, USMC. An interpreter was used for the interview. The following is the transcript from that interview.



Dr. Bill Knarr: Sir, again, we thank you for your time. It's valuable for us to understand your perspective of what happened in Iraq and specifically in Ramadi. To start off, where were you born? Are you from Ramadi?

Colonel Ahmed Hamid Sharqi: I was born in Ramadi City, right in the heart of the center. I was born December 1st, 1973. I finished secondary school. When I finished school, they have a mandatory military induction system, so I got drafted to the Army for three years in the Special Forces with Colonel Ishmael. After an eight month training period with the Special Forces, I was tasked to be in a training academy in Sanjar. I spent four years in the Army total, and after the training academy, I was with the Iraqi Military Police. The last unit I served with was the Iraqi Military Police (MP). After that, I finished my tour with the Iraqi Army (IA) . After that, the Iran-Iraq War started. Part of my training was in the Hit Training Center in 1998. I went and I finished that year, because they recalled me. That's called as a "reserve call." I was in the reserves until 2003 when the regime collapsed. [5:11]

Knarr: What did you do then once the Coalition came in, and how did the insurgency start?

Ahmed: Before the Coalition forces came here, I owned a gas station/truck stop on the border between Jordan and Iraq.

Alford: Al Qaim?

Ahmed: No, Trebil. I owned the truck stop/gas station. I owned a couple of tractor trailers, and I opened a business transporting goods between Syria and Iraq. I had my 18 wheelers run-

ning between Tartus, which is on the Mediterranean Sea in Syria, all the way to Baghdad. I also had a route running from Latakia Port in Syria, another Mediterranean Port.

The insurgents started controlling the highways and affecting my trade. They start taking my trucks and goods. Then I started my own Personal Security Detachment (PSD) to escort my own trucks all the way from Syria, through the Iraqi Borders, and into Baghdad, so the terrorists wouldn't take my goods. At that time, I didn't have any communication whatsoever with the Coalition forces. It was very critical, because I had seven civilian armed vehicles accompanying and escorting my convoys, and I was afraid that Coalition forces would be on the highway, see my armed civilian vehicles, and shoot at them. I would send one vehicle ahead with a cell phone, and they would scout the route. If they saw Coalition forces, they would let the others know. If there were terrorists along the way, they would go and engage them. I got bothered a lot by the Syrian Intelligence, because they understood that I was escorting convoys. It got so bad that I left the business there and shut down the office. When I used to go to Syria, I would take two passports with me. One was fake with a different name, and one was my real passport. The reason was in case I got caught in Syria and they put out an All Points Bulletin (APB) on my name, I'd have my other passport with the real name just to go back the last time; it was my ticket back. It got too hectic for me to go to Syria, so I left Syria and came back here.

In 2004/2005 Al-Qaeda planted its roots in Ramadi, and they killed a lot of my close relatives, including my cousin, the Sheikh of my tribe. They killed a lot of the high ranking tribal leaders in Ramadi. They killed my uncle, they killed my other uncle from my mother's side- they killed everybody! In September 2006 a bunch of terrorists went into my cousin's house, right next to my house, and they tried to kill him at six o'clock in the morning. The women and children in the house start screaming because of the attack, and the terrorists started shooting through the windows and the doors without distinguishing who they were shooting at. That was the spark that caused the whole neighborhood to start attacking these guys. We started shooting at them from the top of the buildings. [13:45]

Knarr: Exactly where was this?

Ahmed: Right next to my house which is 200 meters away from the Provincial Government Center (PGC.) This is where I used to live. It's right next to the head of the police. The insurgents had everybody in their hand: the Oil Ministry, the Oil Department, everyone. They announced an Islamic state in the city of Ramadi, and they started ruling.

Knarr: When was that?

Ahmed: In 2004/2005 they [the insurgents] were already governing and ruling as an Islamic state in Ramadi. After the incident when they attacked my house and my neighborhood, all my guys and my relatives dug up their weapons. They had these from when they used to be smugglers. I am saying this openly; I used to be a smuggler.

Alford: Good Smuggler.

Ahmed: Yes. We only had like five pieces of medium range weapons, which are PKC machine guns. Our concern wasn't the terrorists, our concern was that the Coalition forces would think that we were terrorists, because we were carrying weapons and the terrorists have weapons. We didn't have that connection with the Coalition forces, so I went to meet with the Sheikh Abdul Sattar Buzaigh Abu Risha, so he could communicate to the Coalition forces. I was a very good friend of Sheikh Abu Risha and Ahmed Abu Risha and their brother, and I used to hide in their houses when Saddam Hussein was looking for me. They used to be my shelter and we were extremely close friends. I talked to Sheikh Abu Risha and told him, "Please let the Coalition forces understand that we are trying to find the terrorist. Just don't let them hit our houses with their support and assets. They can just give us room to fight. They don't have to interfere. We'll give them the terrorists on a silver platter basically." After Sheikh Abu Risha had the initial communication with the Coalition forces to let us fight terrorists, the Coalition forces were very helpful for me. In the beginning when they were supporting me, they gave us small signs to put on the roof of my family's buildings. The signs were on our roofs so we didn't get air strikes. The Coalition forces established an Area of Operations (AO) for us. They told me that I would be responsible for this AO. So when the Coalition forces come into this AO, they will not encounter or attack any of my armed men." [20:29]

Knarr: I'd like you outline the AO on the map. I'd like you to mark this up.

Ahmed: This is the specific area that had been assigned to us. The Coalition forces would not fire upon us.

Knarr: Were there other people assigned other areas in here by the Coalition?

Ahmed: No, that area was full of terrorists at that time. Let's leave the map, because I am going to tell you how I expanded the area.

Knarr: Good.

Ahmed: Now that they declared that area, any terrorists who would come in, we would shoot them all on sight. We started doing temporary hour or half an hour checkpoints. We put

then in the area between us and Al Jazeera. We start collecting them and their vehicles. We knew them, so we started confiscating their vehicles. We started taking their weapons and vehicles, and turning them into our patrol cars. In the beginning they would hit us with the chemical weapons or attack us. We told them, you do whatever you want, "You already killed most of our families, so there is nothing left. You are just murderers. You are not from this country. You've been sent from outside." [24:17]

Alford: Where were most of them from?

Ahmed: They were being paid by Iranian and Syrian Intelligence. They stopped threatening us and tried talking to us nicely. They even sent some Sheikhs to convince me to come to their side. Sheikh Aba Abu Kabalba from the Sofia area. They offered me as much money as I wanted or anything I asked for to try to persuade me and I refused. I told them, "Either we live with our dignity or we'll die trying." I used to have a big shipping container. I use to use it as a jail, and I told them, "Next time you come in to negotiate, you are going to be in this jail." These names I just mentioned, I worked with them a lot, and the one started putting some kind of identification material on the vehicles and the civilian vehicles.

Alford: Zappa was the guy in charge, as the Executive Officer (XO).

Ahmed: These signs were helpful for us, because they had the Marine's snipers everywhere. When they see these marks, they prevented them from killing my civilian personnel. People would be confused when they went to an area. The people would salute them, you're a good Mujahedeen. People got confused because these Mujahedeen just killed a bunch of other Mujahedeen. This way I started going out of my AO slowly but surely conducting these missions and coming back. At that time they were not IPs, they were just people who were defending their [area].

Knarr: What time was this now?

Ahmed: October 2006. We're still in October. We started just before October, and this story is now in October. The first IP station was constructed by the Marines, and it was the Warar IP station. If I am not mistaken, it was in October 2006. It's called the Warar IP Station, done by the Coalition forces, specifically the Marines. We start conducting joint security. We started asking people to come and volunteer to be an IPs, but people were scared at that time. They didn't want to be involved in the IPs. [30:08]

Knarr: Were they looking at certain, specific tribes that they were asking for the leadership to help them or was it just anyone within that area?

Ahmed: No Sheikh ever helped us in Ramadi. I can challenge any Sheikh saying that he helped in Ramadi. The people were fed up by Al-Qaeda, but the problem was that they couldn't come with us, because there was nobody protecting the people. That's the only obstacle. People were scared. They didn't want to be with Al-Qaeda, but they didn't have any better option. My cousin, Lieutenant Colonel Salam, who is called "The Lion of Ramadi..."

Alford: And was killed when he was protecting Governor Mamoun?

Ahmed: Lieutenant Colonel Salam, my cousin, became the head of the Warar IP station. At that time the people couldn't go out. We couldn't work, and we couldn't drive our cars. So we went and met with Governor Mamoun. He started helping us buy weapons and vehicles, and he gave us a 4,000 dollar bond. The Marines gave us some weapons, but not a lot. We got the support of the governor, the Marines, and the IP station, and we started doing business together. We started doing the raids together with the joint Marine forces. Around November 2006, the terrorists mounted a major attack on our AO. The only casualty they caused with their massive attack was a cow. We killed a lot of them, and we were getting Air Force coverage at the time, basically attack helicopters.

Knarr: Where were you when this attack took place? Were you at the IP station?

Ahmed: The same area that I showed you on the map. They came right in front of my house; my house was the first one they hit. We killed a lot of them. We had mortars; we had RPG7; we had hand grenades; we had the medium machines guns, medium range mortars. [35:06] They hit us with one RPG, we would shoot 20 RPGs. They hit us with one mortar, we would send ten mortars against them. Then we started doing raids on these guys with Colonel Journey. This is why I said that we did not get any help from the Sheikhs; we only got the help from Marines. The Marines became our brothers, our comrades. We slept together, ate together, and fought together. They asked for 20 Jazeera IPs to join ours, because they were already established in Jazeera. The Al-Jazeera guys refused. Lieutenant Colonel Journey was with me in Al-Jazeera. I went with the Colonel to go grab these 20 IPs that were already trained in Jordan as Iraqi IPs. They didn't allow us to have these 20; they didn't want to come to Ramadi. The Jazeera area was tribal and very protective at that time; they didn't give us any. Sheikh Khamid was basically the head of the IPs in Al-Jazeera. He told us, "Everybody clean up his own mess or area." I told him, "Ramadi is not a specific area for one tribe; it's a mix from everybody. We just need the help of everybody." The Marines told me after the meeting, "Forget about it Colonel Ahmed. Don't worry; we are your tribe now." The only guys left with us were

the Marines. They brought us weapons and support. For five months there were no salaries for my guys, the IPs. We had the vehicles, but we couldn't go out to work with it. The terrorists were shooting mortars at us every day. They use to kill a lot of my people after that: women and small children. We couldn't even bury our own dead in Ramadi cemetery. We had to go to Jazeera, because it was more tribal and more secure. This is when Lieutenant Colonel Salam died; the Vehicle Borne Improvised Explosive Device (VBIED) took his life. [39:22]

Knarr: When was this?

Ahmed: Approximately in the beginning of 2007, but I don't have an exact time frame. I just know the area wasn't clear yet. After Lieutenant Colonel Salam died, my IPs elected me to be the head of the IPs in this area. Out of the whole area, there were around 22 guys from my team that really did the hard work. There are a lot of officers that haven't brought even one terrorist to the table. We had so much hate for the terrorists. When the Lieutenant Colonel died, we opened hell on them, and we started raiding them every single day through foot patrols. We didn't go with our vehicles, because there were IEDs everywhere. The way we used to walk to our targets, we used to go from one house to another, not using the streets. The Marines couldn't even interact at that time, because they knew the whole street was full of IEDs. They didn't want to jump from one house to another. We were light enough, and we were jumping from one roof to another until we reached our target, grabbed him, basically kidnapped him, and brought him back.

All these individuals I just mentioned, Zappa and Lieutenant Colonel Journey, they called me to the Palace. Basically, they called me into the camp here, and they talked to me. After that meeting I asked the Marines whose names I just mentioned, "Please give me weapons, and I will start controlling a bigger AO." I remember the Marines handing me 86 AK47s that day. I used a very, very simple tactic. For example, I would go to a specific area at night time and bring concrete barriers to surround that area. We left only one entrance/exit for ourselves, and we just cleared the whole area using 20-30 of my guys. Every day we attacked and cleared. Then I would use some of the guys in there who were really brave, because they knew that there were IPs in the area who would support us in holding the area. I would then pull my guys and do it with another area. By the time I reached the third or fourth area, the guys in the first area already controlled their neighborhood. So I was able to take some of the original guys and put them in another area. [46:00]

I had to clear the area and do raids over 20-30 times per area to keep them cleared, such as the Al-Hose area and Al-Ameen area. People were very scared to join me and were concerned for me; they were begging me, "Let's put the checkpoint right next to your house. It's good protection for you," I said. "No, the terrorists will start shooting mortars, and they might hit my house." I even offered other guys positions as IP officers, and at that time they refused. Now, because of all the peace and the stability, if I say I want one IP, I'll get 1,000 volunteers. Before, it was a different story. Nobody wanted to be in war. Of course now, everybody's a hero. You ask anybody, "Yeah I'm the one who liberated Ramadi!" You want the real truth, the real history; you'll get it from the Coalition forces' documentations. It's better than all of us Iraqis talking about it.

Alford: Journey says you were the first to stand up!

Knarr: Bill Journey and Adel had talked about Entry Control Point (ECP) 295 and the 17th Street IP station; can you talk about how that developed?

Ahmed: Seventeenth Street used to be called 'The Death Street.' There were only Marines at that checkpoint at that time; there was no IP presence. It was right in a hotbed of terrorist activity. They used to shoot at us with RPGs, mortars, and sniper fire. Then I started giving the Marines some IPs to be with them. The IPs that I sent them traveled back and forth every seven days; I would send them a week at a time. They had to be transported by the Coalition forces in Hummers, because they couldn't protect themselves. I called Colonel Journey and told him that "I'm going to put up a small IP station. Do you mind?" He said, "No, don't worry, just go and do whatever you want. Just get rid of these assholes!" We went on foot and knocked door-to-door. Whenever insurgents were found, I took them and dealt with them. We killed a lot of people, but I didn't know at that time that the Marines were watching. They have a G-BOSS or air assets; they were watching and recording everything. I know their system. Every time that we knock on somebody's door, they say "Allah al-Akbar" and then blow themselves up. So now I know how they work. I send my IPs to knock at the door, and the minute they hear "Allah al-Akbar," they shoot the guy before he blows himself up. [52:20]

During that time, the Marines gave me one of these [axe]. I got it from Lieutenant Colonel Journey. The insurgents used to lock the doors from the outside. I use to hit the door with these things and break it down. Then the rumors started that somebody big with the same physical description as me, wearing a mask, and carrying one of these suckers was cutting insurgents' heads off on the sidewalk. It's like the French way, because the body

will stay on the sidewalk, and the head will roll into the street. The rumors started spreading all the way to Syria and other countries around. It's all rumors.

Alford: So people called you Hatchet man.¹

Ahmed: If you see the picture far to the right of the...that's the picture. This is how I dressed. One of the Marines took this picture. A guy from Lieutenant Colonel Journey's team took this picture of me. This is how I used to roll. [54:50]

About the establishment of 17th IP station, I took over by attacking that specific area and the Souk which is the downtown area. Two of my guys died, and they weren't even on the payroll, because they were not established IPs yet. This battle took two days, and then we controlled the area. They killed a lot of Marines and a lot of IPs; they blew up a lot of IEDs on us. They even found US made weapons along with a lot of storage rooms full of TNT and all kinds of weapons. They found at least ten storage units. Four Marines and three IPs died in that specific operation. After the operation, the Marines asked me, "How many terrorists or insurgents did you kill?" I said, "I don't know. I don't think we killed anybody." They said, "No, we saw everything with the night vision and the G-BOSS and everything; you killed a lot of them. You're just not taking credit for it." I started getting volunteers from the same area and put almost a 100 IP guys in that specific station. [57:56]

Knarr: And when was that?

Ahmed: I remember the Warar IP station, October. It was epic for us, because there were missiles on the right and snipers on the left.

This area is ECP 295; there's a lot of fighting. We liberated all this area. We started down here. I closed this area and left only one IP station. This is where we are right now. We started closing all these areas and leaving one entrance. We controlled the whole area.

I am going to tell exactly how I liberated each area. This is where the Jamiad IP station was. This is where the hospital is; that was an IP station. This is the area called company. They called it the IP Station "Shadik," which means company. This is where the Jubuari IP station was, where we liberated the whole neighborhood, the present IP station. We liberated this area and put the IP station Al-Jubauri right here. This is the Al-Zizia IP sta-

¹ Alex Kingsbury, "In Iraq, U.S. Marines Rely on Allies Like Hatchet-Wielding Colonel to Keep the Peace," *U.S. News and World Report*, 30 October 2008.

tion to the north of [Baghdad]. This is Theala IP station. I consolidated most of these IP stations to three major IP stations under my precinct as a part of security. There was Al Haq IP stations. In this area right here, we had one IP station, Al-Haq station. This is the Mala-Miene IP station. I had checkpoints all over the place up until the railroad right there. Lieutenant Colonel Journey had an internal problem with his leadership, and they ordered him to take all his IP checkpoints out of this area.

Alford: Army? Army uniforms?

Ahmed: No it was Marines. They fought over jurisdiction. Maybe two companies were kicked out, and they told him to get his guys out. Lieutenant Colonel Journey told us, "You go and liberate. Get all the insurgents out of it." It reached a point that the other Marines were shooting at my guys, and I had to return fire. I called Lieutenant Colonel Journey and said, "We were shooting at anybody who shot at us." The final decision told to me by Journey was to pull my troops out of these checkpoints. He said, "You take the honor and credit for liberating it, even though the Marines are going to sit there. It doesn't matter." We worked according to precincts and jurisdictions. It was the hottest area, and was liberated only by the Marines. No IPs or Iraqis were involved. Complete credit goes to the Marines. They did it by themselves. And of course everybody wanted credit. [1:06:55]

Alford: When it was easy!

Ahmed: When everything is easy, yes.

Knarr: I'm going to have you go over the map again. We're here now. This is Al Warar, 17th Street IP station? Ok. Jumhuria, Thaila, Sharika, Haq, Hijimouri, Hialime. Ok, good.

Ahmed: Now we have it documented.

Knarr: What is next? When were you finally recognized as police? And when did they start paying you?

Ahmed: October 2006. On March 2007, either March or April.

Knarr: So you started getting paid in March, but you were recognized in October?

Ahmed: No, March 2007 we were recognized as IPs, but the Marines were helping out. They would give us some money to buy some food, and they would share their MREs.

Knarr: What is your biggest concern now, today? [1:09:54]

Ahmed: This is old history. This is all going to be recognized as history. It's going to be documented. Our real concern is our ranks. If one officer tells you, "I have experience with

the schools,” I say, “Ok, I respect that, but you never had the experience that we had from 2006 until this moment.” You can tell an IP officer that he went to school and he graduated, but he never had the experience of fighting Al-Qaeda. He doesn’t know how Al-Qaeda came to Iraq in the first place or how Al-Qaeda brainwashed criminals from criminals to Islamic religious criminals, how they paid specific people to be with them. You can’t learn this in school; you have to be right there in the field to know how to do it. It’s very insulting when cadets communicate with us on bases. When we send documentation, and they say, “Oh you’re a temporary honorary rank.” They are just degrading us by saying that. I am not a vehicle coming over the border with a temporary license plate sticker on the bumper. They are just undermining all that we’re doing. That’s our main concern at this time.

What I need from you is to try to work on recognizing these ranks. Consider treating me as a colonel, like I am officially, with the Ministry of Interior (MOI). I am not talking about myself only. All of the officers don’t have our ranks recognized. Our work morale is very low because of this; we’re not producing almost 40% of what we are supposed to, because we don’t have the job security. Every now and then people tell us, “Ok, the government is changing; you’re going to be kicked out in the streets.” Before, they told us that we were doing a good job. Now they can basically tell us at anytime, “Hey, get out of here.” It’s very important. Applications from MOI come, and they ask, “Hey, who gave you this rank?” And we will say, “Coalition forces gave me this rank.” They do not recognize it. They tell me, “You cannot keep this rank, because we didn’t issue it to you.” It doesn’t make sense after we cleared and secured the whole country, and now they want to kick us out or not recognize us. In the delegation we’ll say in a very fun tone, “Ok, let the Coalition forces guarantee your rank.” It only takes four months, but it’s provided by the MOI. And if they go to that course, they’ll be the same as graduated Police Academy candidates. They still didn’t give us that, so that’s the only obstacle. If you guys can help with that, providing the new government, hopefully, give them these courses. [1:15:23]

Knarr: I really appreciate your time. You’re the one that Colonel Journey said, “You have to talk to Colonel Ahmed, because he’s a brave man. He did a lot for this country and for Ramadi.” So, Sir, thank you! It’s an honor to be here.

Appendix C. Who's Who

Interviewees

- Abd al-Hakim Muhammad Rashid Muhammad al-Jughayfi**, Mayor of Hadithah
- Abdul Qadir Mohammed Jassim Obeidi al-Mifarji**, General, Minister of Defense from 2006 to present, preceded by Dr. Sadun al-Dulaymi, Sunni Arab, born in Ramadi
- Abdullah Jallal Mukhlif al-Faraji**, Head of Sunni Endowment for Anbar Province, Regent Sheikh of the Albu-Faraj tribe; Ramadi City Council Member
- Adel**, Brigadier General, Commander 1st Brigade, 1st Iraqi Division
- Ahmad Jelayan Khalaf**, former Desert Protector
- Ahmed Bezia Fteikhan al-Rishawi**, Paramount Sheikh of the Albu-Risha tribe, President of Muttamar Sahawat al-Iraq (MSI)
- Ahmed Hamid Sharqi**, Colonel, Chief, North Ramadi Police Precinct
- Aum Ahmed**, resident of Al Qaim
- Babakir Badr-khan Shawat al-Zubari**, General, Chief of Staff for the Joint Forces Command, Studied at the Iraqi Military Academy in Baghdad in 1969, served in the Kurdish Peshmerga 1973–91; Escaped to Iran as a political refugee in 1975; Acting Commanding General of Iraqi Joint Headquarters, 2004–05; Chief of Staff, Iraqi Joint Headquarters, 2005 to present
- Bakhit Arak Ali**, Lieutenant Colonel, Commander, Qatana Police Station, Ramadi
- Bezi Mujjil Nijris al-Gaoud al-Nimrawi**, eldest Sheikh of the Albu-Nimr tribe; one of the first tribal leaders to offer to arm tribesmen and support Coalition (Summer 2003); turned down by CPA over concerns of creating tribal militias; lives in Amman, Jordan
- Farouq Tareh Harden al-Jughayfi**, Colonel, Police Chief Hadithah
- Hareth al-Dhari**, (Dr.) Leader of the Association of Muslim Scholars (AMS) and Zobai tribe
- Ibrahim al-Jaafari**, former Iraqi Prime Minister, April 2005 to May 2006
- Ismael Sha Hamid Dulaymi**, staff Brigadier General Former Commander 28th Iraqi Brigade, 7th Iraqi Army Division
- Jalal al-Gaoud**, Iraqi Businessman from Hit, residing in Jordan

Jassim Muhammad Salih al-Suwaydawi, sheikh of the Abu-Souda tribe

Kurdi Rafee Farhan Al-Mahalawi, lower tier sheikh of Abu-Mahal tribe

Mahmood al-Janabi, a leader with the Jaish al-Islami (Islamic Army) insurgent group

Majed Abd al-Razzaq Ali al-Sulayman, Sheikh of the Dulaymi Confederation

Mamoun Sami Rashid Latif al-Alwani, former Governor of Anbar; Anbar Provincial Council Member; Chairman of the Provincial Council's Economic Committee

Mishan Abbas Muhammad al-Jumayli, Paramount Sheikh of the Abu-Jumayli tribe

Mohammed Al-Saady, Special Advisor to the Prime Minister and Chairman of the Implementation and Follow-up Committee for National Reconciliation. Recently elected to the new Parliament.

Mukhlis Shadhan Ibrahim al-Mahalawi, Desert Protectors commander

Nathem al-Jabouri, former member of AQI

Numan al-Gaoud, businessman and member of the Abu-Nimr tribe in Hit

Raad Majid Rashid al-Hamdani, Lieutenant General, Retired Republican Guard Commander; Leader of the FRE Movement to Reintegrate with GOI

Raja Farhan, mayor of Al Qaim

Sa'fa Al-Sheikh, National Security Advisor

Sa'id al-Jughayfi, Sheikh of the Jughayfi tribe in Hadithah

Sabah al-Sattam Effan Fahren al-Shurji al-Aziz, principal Sheik of the Abu-Mahal tribe in Al Qaim

Sadun Juwayr Farhan al-Rishawi al-Dulaymi, Doctor, Former Minister of Defense 2005/2006, Doctorate in Social Psychology from United Kingdom's Keele University

Said Flayyah Othman al-Jughayfi, contesting Sheikh, Abu-Jughayfi, one of the top 17 influential tribes in Anbar, Hadithah

Sha'ban Barzan Himrin, Colonel, former Chief of Police in Baghdadi

Sheikh Ali Hatim Abd al-Razzaq Ali al-Sulayman al-Assafi al-Dulaymi, President of the Common Council of Iraqi and Arab Sheikhs, Lineal Sheikh-in-waiting of the Abu-Assaf tribe, Founder of the Iraqi National Front

Tariq al-Abdullah al-Halbusi, Principle Sheik of the Halbusi tribe located in Fallujah

Thamer Kadhem al Tamimi, closely associated with JAI; one of the first and premier Saha-wa leaders in Baghdad

Thamir Ibrahim Tahir al-Assafi, Doctor, Head of the Muslim Ulema Council (MUC) for Anbar and Senior Theologian to Sunni Waqf; Ramadi City Council member; Al-Anbar University (AAU) Professor of Religious Studies; Mutammar Sahawat al-Iraq (MSI) office of Religious Affairs

Thary Abed Alhadi al-Yousef al-Zobi, Deputy Governor, on the Awakening

Other Notable People

Abdul Sattar Abu-Risha, Leader of the Awakening movement in the Al Anbar Area, assassinated 13 September 2007

Abdullah al-Janabi, close supporter, organizer, and religious advisor to many of the insurgent groups growing in and around Fallujah during the summer of 2003; became one of the key influential insurgent leaders during both battles of Fallujah (2004)

Abu Ayyub al-Masri, replaced Zarqawi as leader of AQI following the former's death in June 2006; created Islamic State of Iraq in October 2006

Abu Musab al-Zarqawi, Jordanian-born founder of *Jama'at Al-Tawhid Wa'al Jihad* (JTJ – Group of Monotheism and Holy War) (2003) and later Al-Qaeda in Iraq (October 2004); killed in Coalition airstrike in June 2006

Amer Abd al-Jabbar Ali Sulayman al-Assafi al-Dulaymi, Co-Paramount Sheikh of the Albu-Assaf tribe and Co-Sheikh General of the Dulaymi Confederation

Faisal al-Gaoud, former Sheikh of Albu-Nimr; father of Sheikh Fasal

Fasal Rakan Nejris, Sheikh of Albu-Nimr tribe; appointed governor of Anbar by IIG November 2004; replaced as governor by Raja Nawaf Farhan al-Mahalawi (May 2005); Awakening Council leader; died 25 June 2007 in Mansour Hotel bombing

Hamid Farhan al-Heiss, from the Albu-Thiyab tribe; member of the Anbar Salvation Council; don't confuse him with his brother, Sheikh Muhammad Farhan al-Heiss and contesting lineal sheikh of the Albu-Thiyab tribe

Hatim Razzaq, current Sheikh of Albu-Nimr

Hikmat Jubayir, mayor of Hit; Sheikh of Albu-Nimr tribe

Karim Burjis al-Rawi, former governor of Anbar Province (April 2003–August 2004); forced to resign after his sons were kidnapped; replaced by Mohammad Awad

Khalid al Irak al-Jassim, leader of the Albu-Ali Jassim tribe, killed by AQI

Khalid Araq Ataymi al-Iliyawi, well respected Ali Jassim tribal leader brutally murdered by AQI (August 2006); his body was hidden preventing burial for three days, violating both tribal and Islamic custom; catalyst for tribal resistance to AQI in the Ramadi area

Lawrence Mutib Mahruth al-Hathal al-Aniza, Paramount Sheikh of the Abu-Aniza tribe, Mayor of Nukhayb, Anbar, Iraq

Mudhir Abdul Karim Thiab al-Kharbit, son of Sheikh Malik; assumed leadership of clan upon his father's death; Ba'athist supporter and strongly anti-Coalition following his father's death

Muhammad Mahmoud Latif, leader of the 1920 Revolutionary Brigades and Ramadi Shura council

Muqtada al-Sadr, Shia cleric and leader of the Mahdi Militia

Naim Abd al-Muhsin al-Gaoud, appointed by Coalition forces as first mayor of Hit (April 2004)

Nayil al-Jughayfi, seized control of Hadithah during initial invasion; subsequently recognized by Coalition as first mayor (April 2004)

Raja Nawaf Farhan al-Mahalawi, appointed governor of Anbar by newly-elected provincial council (May 2005); kidnapped by extremist elements to influence Abu-Mahal to stop fighting AQI; found dead in a home after Coalition-insurgent fighting in the area; replaced by Mamoun Sami Rasheed

Razak Salim Hamza, former commander 1st Brigade, 1st Iraqi Division

Sheikh Malik al-Kharbit, tribal leader of the Khalifawi (Ramadi area); head of one of the most important families in the powerful Dulaymi tribal federation; cooperated with Coalition forces before the invasion; tragically killed along with between 17 and 22 family members, including women and children during mistaken Coalition airstrike on his compound (11 April 2004); cited as motivating factor turning Ramadi-area tribes against Coalition

Talal al-Gaoud, son of Bezi al-Gaoud; worked with Marines engagements in Jordan in 2004; died suddenly in 2006

Tariq Abdul Wahab Jasim, former Commander Iraqi First Division

Appendix D. Maps

Note: North is towards the top of all maps as you read them.

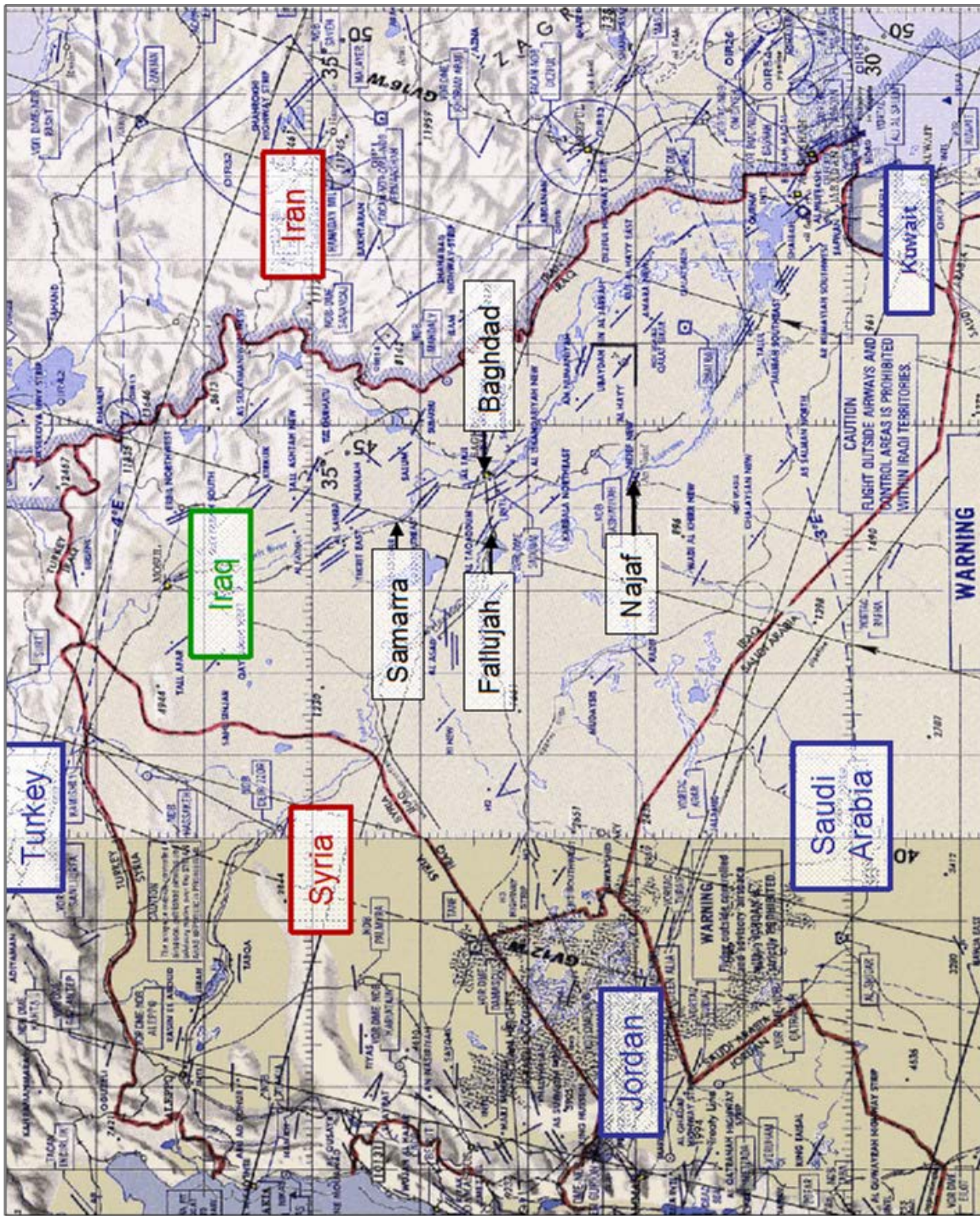

Base map courtesy of National Geospatial Agency

Figure D-1. Map of Iraq and its neighbors

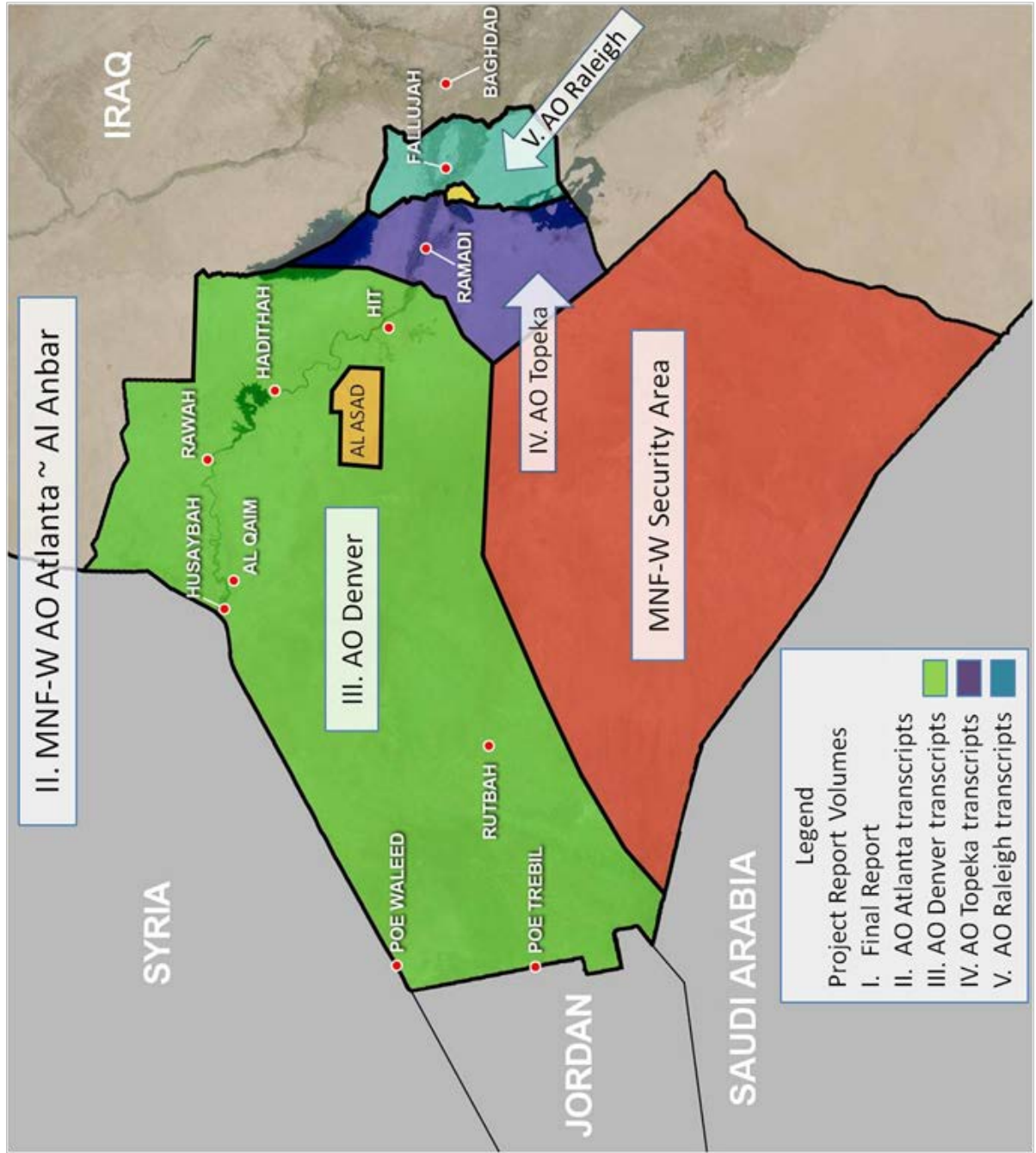

Area of Operation boundaries extracted from map courtesy of I-MEF and USMC History Division

Figure D-2. Map of military operational areas in Iraq during 2004

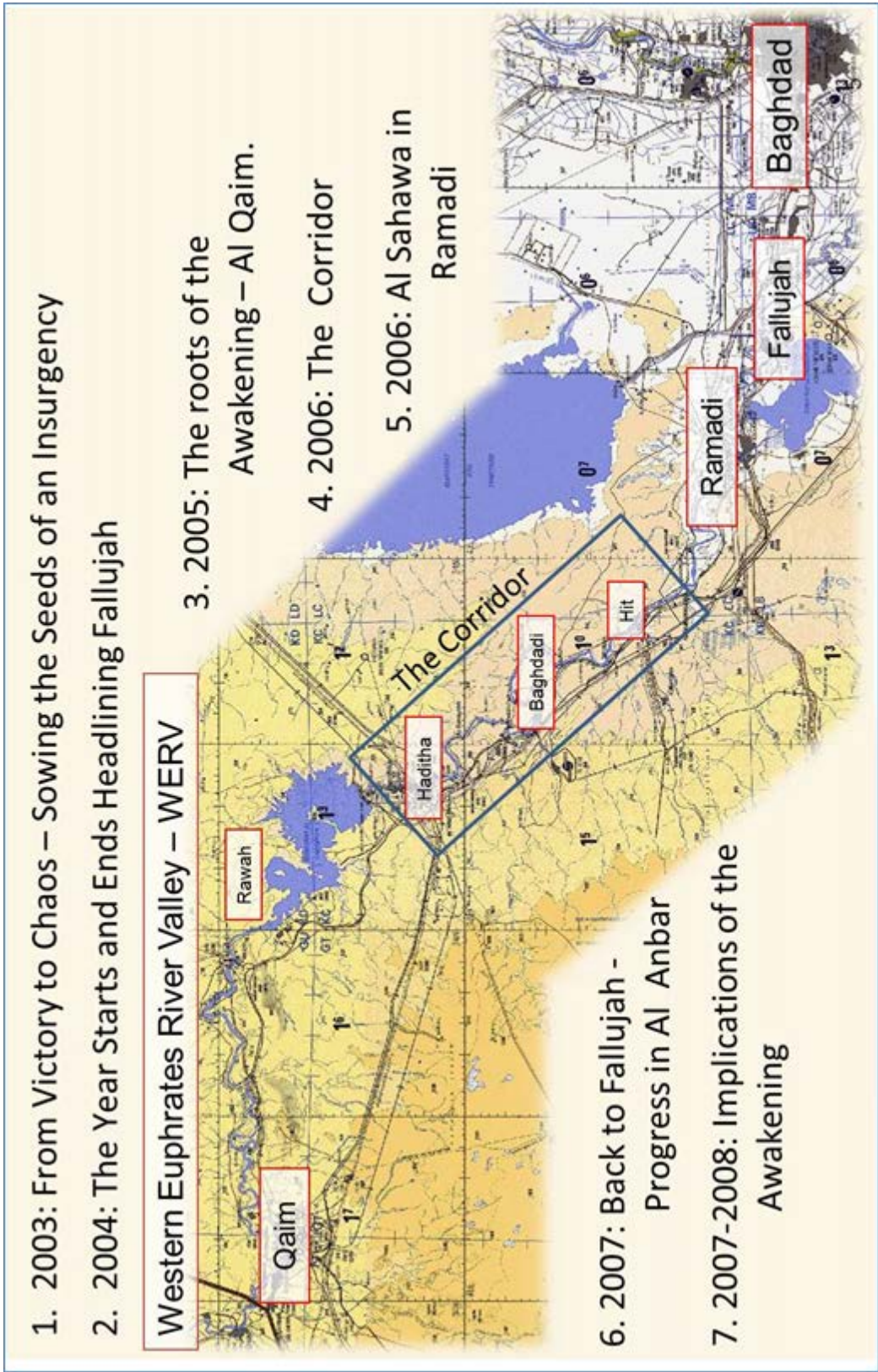

Figure D-3. Phases of the Al Anbar Awakening

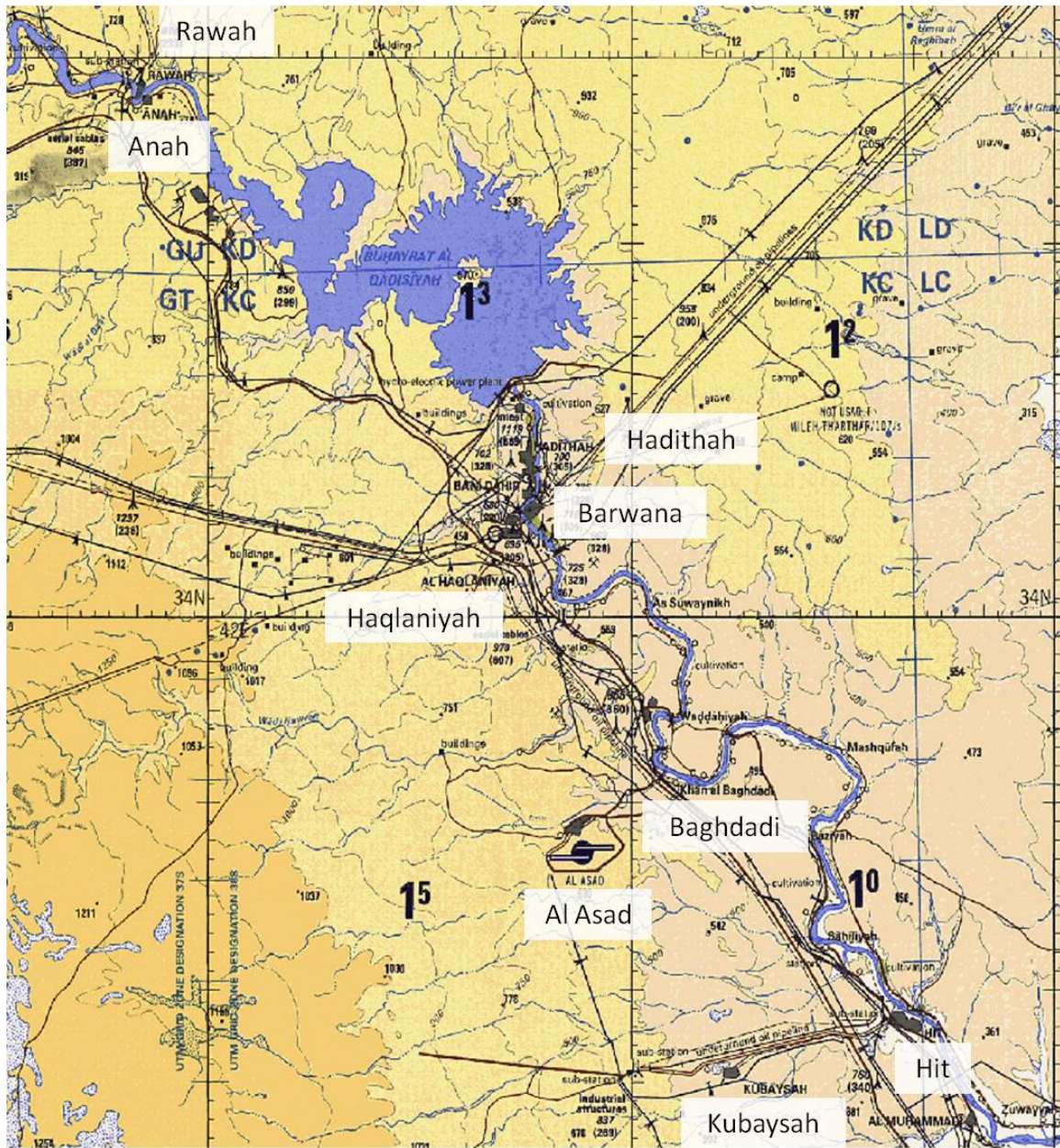

Figure D-5. Map of Hadithah area

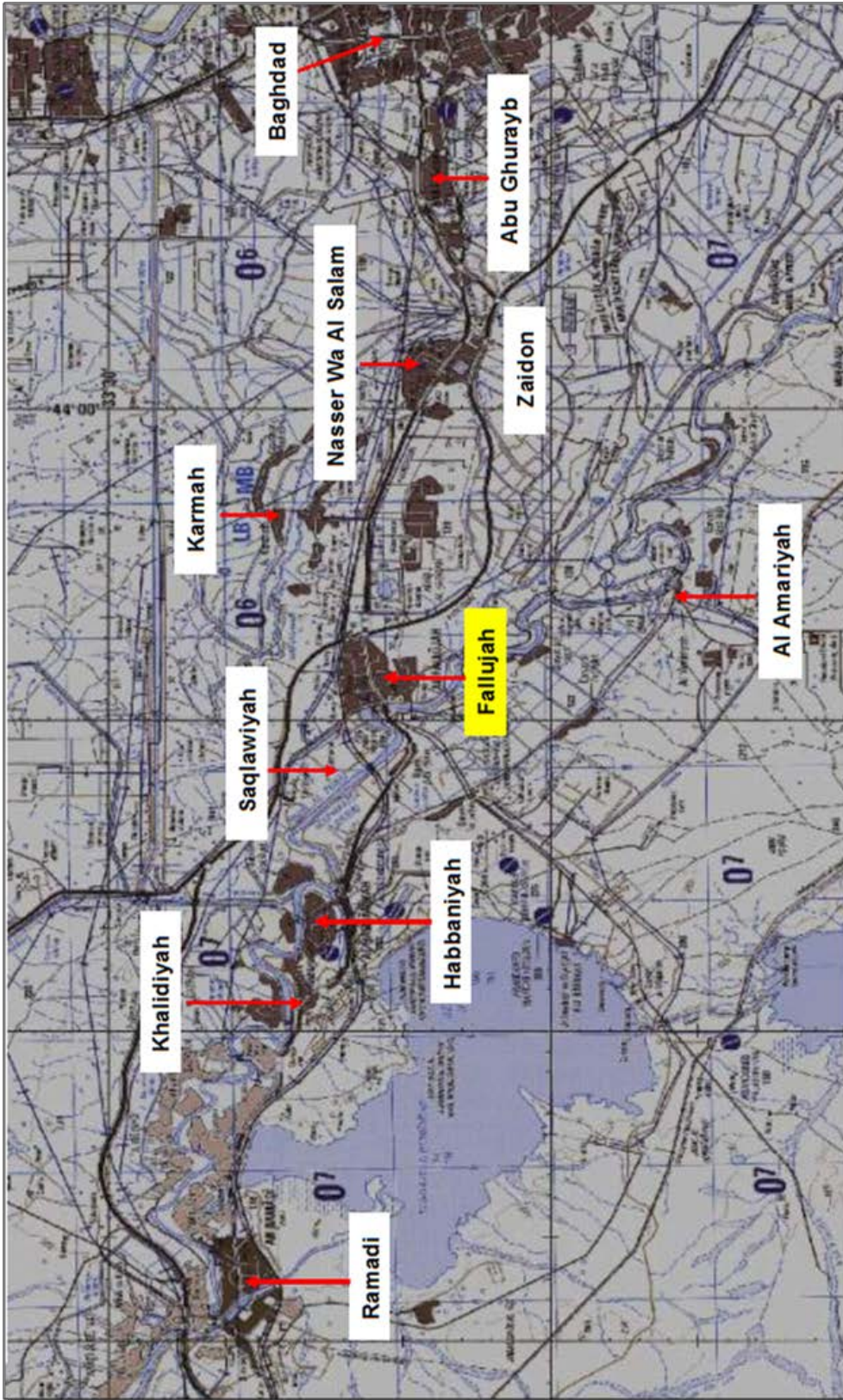

Image courtesy of 1st MARDIV

Figure D-8. Map of Fallujah and surrounding cities

Appendix E. Illustrations

Areas of Operation in Al Anbar provide the structure for the Awakening volumes	v
Figure 1-1. Areas of Operation in Al Anbar provide the structure for the Awakening volumes	1-4
Figure 2-1. Status of Tribal Attitudes towards the Coalition in the Ramadi District in June 2006.....	2-2
Figure 2-2. AO Topeka and RFCT’s Initial Combat Maneuver Battalion Deployment.....	2-4
Figure 2-3. TF 1-35 Armor AO	2-6
Figure 2-4. TF 1-35 Task Organization	2-7
Figure 2-5. 20 July 2006 at Sheikh Stattar’s house.....	2-10
Figure 2-6. 9 September 2006 Meeting.....	2-12
Figures 2-7: Sheikh Sattar announces the Awakening.....	2-13
Figure 2-8. TF 1/6 Marines Area Orientation	2-15
Figure 2-9. 17th Street Security Station in the middle of AQI-held territory held by 1/6 Marines during Operation BELLEAU WOOD	2-17
Figure 2-10. Operation HUE CITY’s aim was to construct the Qatana IP Station	2-20
Figure 2-11. Insurgents rigged buildings to detonate when Coalition forces entered	2-21
Figure 2-12. TF 1-9 AO, Mula’ab section of East Ramadi and east through Julaybah.....	2-22
Figure 2-13. Colonel Ahmed Hamid Sharqi	2-23
Figure 2-14. Status of Tribal Attitudes towards the Coalition in the Ramadi District in December 2006.....	2-24
Figure 2-15. Clearing Operations in Ramadi	2-26
Figure 2-16. Daily Attacks in AO Topeka from 1 January 2007 to 19 March 2008	2-27
Figure D-1. Map of Iraq and its neighbors.....	D-2
Figure D-2. Map of military operational areas in Iraq during 2004.....	D-3
Figure D-3. Phases of the Al Anbar Awakening.....	D-4
Figure D-4. Map of Al Qaim area	D-5
Figure D-5. Map of Hadithah area	D-6
Figure D-6. Map of Al Asas/Hit area.....	D-7
Figure D-7. Map of Ramadi area	D-8
Figure D-8. Map of Fallujah and surrounding cities.....	D-9
Table 1-1. Initial Primary and Secondary Research Questions for the Awakening Project.....	1-2
Table 1-2. Transcripts in Volume IV	1-5
Table A-1. Brigade/Regimental Units Responsible for AO Topeka, 2003–08.....	A-1

Appendix F. References

- Anderson, John Ward, "Iraqi Tribes Strike Back at Insurgents," *Washington Post*, 7 March 2006.
- Deane, Colonel Anthony E., USA, "Providing Security Force Assistance in an Economy of Force Battle," *Military Review* (Jan-Feb 2010).
- Finer, Jonathan, "How U.S. Forces Found Iraq's Most-Wanted Man," *Washington Post*, 9 June 2006.
- I-MEF G2, "State of the Emergency in Al Anbar," I MEF G-2, 17 August 2006, cleared for open publication 16 December 2010 by the Office of Security Review, Department of Defense and declassified by US Central Command Memorandum 10-012, at the request of Dr. William Knarr.
- Linzer, Dafna and Thomas Ricks, "Anbar Picture Grows Clearer and Bleaker," *Washington Post*, 28 November 2006.
- Morin, Monty "Suicide Bomber Kills Dozens of Iraqi Police Recruits and Two Americans," *Stars and Stripes*, 6 January 2006.
- Parker, Ned and Mohamed Al-Kubacy, "Arm Tribes to Fight Al Qaeda, Say Sunnis," *The Times*, 13 September 2006.
- Patlow, Joshua, "Zarqawi Group Vows to Press Attacks," *Washington Post*, 12 June 2006
- Patlow, Joshua, and Michael Abromowitz, "Officials Detail Zarqawi's Last Hour," *Washington Post*, 13 June 2006.
- Ricks, Thomas E. "Situation Called Dire in West Iraq," *Washington Post*, 11 September 2006.
- Rubin, Alissa J., "Sunni Sheikh Who Backed US in Iraq Killed," *New York Times*, 14 September 2007.
- .

Appendix G. Abbreviations

ACR	Armored Cavalry Regiment
AID	Agency for International Development
AO	Area of Operation
AQI	Al Qaeda in Iraq
BCT	Brigade Combat Team
BLT	Battalion Landing Team
BrigGen	Brigadier General–US Marine Corps
BG	Brigadier General–US Army
CA	Civil Affairs
Capt	Captain, US Marine Corps or US Air Force
Cav	cavalry
CENTCOM	US Central Command
CERP	Commander Emergency Response Program
CG	Commanding General
CMO	Civil-Military Operations
COL	Colonel, US Army
Col	Colonel, US Marine Corps or US Air Force
COP	Combat Outpost
CP	command post
CPA	Coalition Provisional Authority
CT	counterterrorism
ECP	entry control point
FM	field manual
FOB	Forward Operating Base
FRAGO	Fragmentary Order
G-3	Army or Marine Corps component operation staff officer (Army division or higher staff, Marine Corps brigade or higher staff)
GEN	General, US Army
Gen	General, US Marine Corps or US Air Force
GOI	Government of Iraq
HUMINT	Human Intelligence
IA	Iraqi Army
ICDC	Iraqi Civil Defense Corps
IDA	Institute for Defense Analyses
IED	improvised explosive device
IG	Iraqi Government
IIP	Iraqi Islamic Party
ING	Iraqi National Guard
IO	information operations

IR	Information Requirement
ISF	Iraqi Security Forces
JAI	Jaish al-Islami [Islamic Army]
JAWP	Joint Advance Warfighting Program
JFCOM	United States Joint Forces Command
KIA	Killed in Action
LAR	Light Armored Reconnaissance
LNO	liaison officer
LOO	Lines of Operation
LtGen	Lieutenant General, US Marine Corps
LTC	Lieutenant Colonel, US Army
LT Col	Lieutenant Colonel, US Air Force
LtCol	Lieutenant Colonel, US Marine Corps
LTG	Lieutenant General, US Army
MAJ	Major, US Army
Maj	Major, US Marine Corps or US Air Force
MajGen	Major General, US Marine Corps
MARDIV	Marine Division
MEF	Marine Expeditionary Force
MEU	Marine Expeditionary Force
MG	Major General, US Army
MiTT	Military Transition Team
MNC-I	Multi-National Corps–Iraq
MND	Multi-National Division
MNF-I	Multi-National Forces–Iraq
MNF-W	Multi-National Forces-West
MOD	Ministry of Defense
MOI	Ministry of Interior
MOS	Military Occupational Specialty
MSR	main supply route
MTOE	Modified Table of Organization and Equipment
NCO	non-commissioned officer
NGO	Non-governmental organization
NSC	National Security Council
ODA	Operational Detachment Alpha
OGA	Other Governmental Agencies
OIF	Operation IRAQI FREEDOM
OPORD	operations order
OVR	OPERATION VIGILANT RESOLVE
POC	point of contact
POO	point of origin
RCT	Regimental Combat Team
ROE	rules of engagement

RPG	rocket propelled grenade
PRT	Provincial Reconstruction Teams
PsyOps	Psychological Operations
S-3	battalion or brigade operations staff officer (Army; Marine Corps battalion or regiment)
SEAL	Sea, Air, Land Team
SFG	Special Forces Group
SFODA	Special Forces Operational Detachment Alpha
SIGACT	Significant Activity Report
SIPR	Secure Internet Protocol Router
SOF	Special Operations Forces
SOI	Sons of Iraq
TO	Table of Organization
TOA	Transfer of Authority
TOC	tactical operations center
TRADOC	Training and Doctrine Command (US Army)
UAV	unmanned aerial vehicles
VBIED	vehicle-borne improvised explosive device
WERV	Western Euphrates River Valley
WMD	Weapons of Mass Destruction
XO	Executive Officer

REPORT DOCUMENTATION PAGE			Form Approved OMB No. 0704-0188		
Public reporting burden for this collection of information is estimated to average 1 hour per response, including the time for reviewing instructions, searching existing data sources, gathering and maintaining the data needed, and completing and reviewing this collection of information. Send comments regarding this burden estimate or any other aspect of this collection of information, including suggestions for reducing this burden to Department of Defense, Washington Headquarters Services, Directorate for Information Operations and Reports (0704-0188), 1215 Jefferson Davis Highway, Suite 1204, Arlington, VA 22202-4302. Respondents should be aware that notwithstanding any other provision of law, no person shall be subject to any penalty for failing to comply with a collection of information if it does not display a currently valid OMB control number. PLEASE DO NOT RETURN YOUR FORM TO THE ABOVE ADDRESS.					
1. REPORT DATE (DD-MM-YY) August 2016		2. REPORT TYPE Paper (Final)		3. DATES COVERED (From - To) November 2009 to September 2013	
4. TITLE AND SUBTITLE <i>Al Sahawa—The Awakening</i> <i>Volume IV: Al Anbar Province, Area of Operations Topeka, Ramadi</i>			5a. CONTRACT NO. DASW01-04-C-0003		
			5b. GRANT NO.		
			5c. PROGRAM ELEMENT NO(S).		
6. AUTHOR(S) Dr. William (Bill) Knarr, Task Leader; Col Dale Alford, USMC; Ms. Mary Hawkins; LtCol David Graves, USMC; Ms. Jennifer Goodman; Mr. Matthew Dobson; Ms. Carolyn Leonard; Mr. John Frost; Col Tracy King, USMC; MajGen Thomas Jones, USMC, (Ret); Mr. Matt Coursey			5d. PROJECT NO.		
			5e. TASK NO. AI-8-2827.37 & BE-8-3035, Anbar Awakening - COIN		
			5f. WORK UNIT NUMBER		
7. PERFORMING ORGANIZATION NAME(S) AND ADDRESS(ES) Joint Advanced Warfighting Division Institute for Defense Analyses 4850 Mark Center Drive Alexandria, VA 22311-1882			8. PERFORMING ORGANIZATION REPORT NO. IDA Paper P-5052 Log no. H 13-001038		
9. SPONSORING / MONITORING AGENCY NAME(S) AND ADDRESS(ES) Director, Joint Force Development (J-7) 7000 Joint Staff Pentagon 2D763 Washington, DC 20318-7000 703-695-6478[61]			10. SPONSOR'S / MONITOR'S ACRONYM(S) J7		
			11. SPONSOR'S / MONITOR'S REPORT NO(S).		
12. DISTRIBUTION / AVAILABILITY STATEMENT Approved for public release; distribution is unlimited.					
13. SUPPLEMENTARY NOTES (U)					
14. Abstract The objective of the Anbar Awakening project was to create an unclassified resource for trainers and educators. It is presented in multimedia to accommodate different teaching and learning styles. The project presents the Awakening movement's phases from the development of the insurgency in 2003 to the Coalition's transfer of responsibility for Al Anbar to the Iraqis in 2008. In addition, it offers analysis and lessons, many of which are transferrable to current and future conflicts. Most popular narratives of the Anbar Awakening associate the beginning of the movement with a 14 September 2006 proclamation by Sheik Abdul Sattar Albu-Risha where he coined the term <i>Al Sahawa</i> . This project contends that there was a robust connection in terms of events and relationships from Fallujah in 2004 to Al Qaim in 2005 to the Hadithah-Hit Corridor in 2006, to Ramadi in 2006/2007 and back to Fallujah in 2007/2008; that connection was based on Iraqi culture and societal networks that Americans were not part of. This document, Volume IV, addresses events in the Ramadi district of the Coalition's Area of Operations (AO) Topeka. This was a fight made more difficult because insurgents were forced into the Ramadi area from the west/northwest and east.					
15. SUBJECT TERMS Awakening, Sahawa, Anbar, lessons learned, Operation Iraqi Freedom, battle reconstruction,					
16. SECURITY CLASSIFICATION OF:			17. LIMITATION OF ABSTRACT UU	18. NO. OF PAGES 422	19a. NAME OF RESPONSIBLE PERSON LtGen Thomas D. Waldhauser, USMC
a. REPORT U	b. ABSTRACT U	c. THIS PAGE U			19b. TELEPHONE NUMBER (Include Area Code) 703-695-6478[61]

